

# Installation Manual

## CHART RADAR

### Model FAR-3210(-BB)/3220(-BB)/3310/3320

(Product Name: Marine Radar)

<b>SAFETY INSTRUCTIONS</b> .....	i	3.10 How to Change the Display Color for Sensor Data Based on Integrity .....	3-15
<b>SYSTEM CONFIGURATION</b> .....	iii	3.11 How to display the [Echo] page .....	3-16
<b>EQUIPMENT LISTS</b> .....	vi	3.12 Web Setting Menu .....	3-16
<b>1. INSTALLATION</b> .....	<b>1-1</b>	<b>4. INPUT/OUTPUT DATA</b> .....	<b>4-1</b>
1.1 Antenna Unit .....	1-1	4.1 Processor Unit .....	4-1
1.2 Monitor Unit .....	1-7	4.2 IEC 61162 Sentences .....	4-2
1.3 Radar Control Unit, Trackball Control Unit .....	1-7	 	
1.4 Power Supply Unit .....	1-10	<b>APPENDIX 1 JIS CABLE GUIDE</b> .....	<b>AP-1</b>
1.5 Processor Unit .....	1-11	<b>APPENDIX 2 ROD TERMINALS</b> .....	<b>AP-2</b>
1.6 Sensor Adapters (option) .....	1-12	<b>APPENDIX 3 DIGITAL INTERFACE</b> .....	<b>AP-7</b>
1.7 Intelligent HUB (option) .....	1-13	 	
1.8 Switching Hub (option) .....	1-15	<b>PACKING LISTS</b> .....	<b>A-1</b>
1.9 Junction Box (option) .....	1-15	<b>OURLINE DRAWINGS</b> .....	<b>D-1</b>
 		<b>INTERCONNECTION DIAGRAMS</b> .....	<b>S-1</b>
<b>2. WIRING</b> .....	<b>2-1</b>		
2.1 Overview .....	2-1		
2.2 Antenna Unit .....	2-4		
2.3 Processor Unit .....	2-14		
2.4 Power Supply Unit .....	2-24		
2.5 Monitor Unit .....	2-28		
2.6 Sensor Adapters (option) .....	2-29		
2.7 LAN Signal Converter Kit (option) .....	2-44		
2.8 Junction Box (option) .....	2-51		
2.9 Intelligent HUB (option) .....	2-53		
2.10 How to Extend the Control Unit Cable (option) .....	2-54		
<b>3. SETTINGS AND ADJUSTMENTS</b> .....	<b>3-1</b>		
3.1 How to Access the Radar Installation Menu .....	3-1		
3.2 How to Align the Heading .....	3-1		
3.3 How to Adjust the Sweep Timing .....	3-2		
3.4 How to Suppress Main Bang .....	3-3		
3.5 Dual Radar Display .....	3-3		
3.6 Other Settings .....	3-6		
3.7 Network Transmission Setting Between ECDIS and Radar .....	3-13		
3.8 How to Set the Forwarding Distance ...	3-13		
3.9 Synchronization With Ship's Clock ...	3-14		



**FURUNO ELECTRIC CO., LTD.**

[www.furuno.com](http://www.furuno.com)

All brand and product names are trademarks, registered trademarks or service marks of their respective holders.

**ECF**

(Elemental Chlorine Free)

The paper used in this manual  
is elemental chlorine free.

**FURUNO ELECTRIC CO., LTD.**

9-52 Ashihara-cho,  
Nishinomiya, 662-8580, JAPAN

• FURUNO Authorized Distributor/Dealer

All rights reserved. Printed in Japan

Pub. No. IME-36160-J

(AKMU ) FAR-3210

A : APR. 2014

J : MAY 18, 2018





0 0 0 1 7 8 0 3 1 1 8





# SAFETY INSTRUCTIONS

The installer of the equipment must read the applicable safety instructions before attempting to install the equipment.

 <b>DANGER</b>	Indicates a potentially hazardous situation which, if not avoided, will result in death or serious injury.
 <b>WARNING</b>	Indicates a potentially hazardous situation which, if not avoided, could result in death or serious injury.
 <b>CAUTION</b>	Indicates a potentially hazardous situation which, if not avoided, can result in minor or moderate injury.

 Warning, Caution	 Prohibitive Action	 Mandatory Action
--	--	--

** DANGER**

 **Wear a safety belt and hard hat when working on the antenna unit.**

Serious injury or death can result if someone falls from the radar antenna mast.

** WARNING**

 **Radio Frequency Radiation Hazard**

The radar antenna emits electromagnetic radio frequency (RF) energy which can be harmful, particularly to your eyes. Never look directly into the antenna aperture from a close distance while the radar is in operation or expose yourself to the transmitting antenna at a close distance. Distances at which RF radiation level of 100, 50 and 10 W/m<sup>2</sup> are given in the table below.

If the antenna unit is installed at a close distance in front of the wheel house, your administration may require halt of transmission within a certain sector of antenna revolution. See the installation manual for how to manage blind sectors.

Model	Transceiver	Antenna*	100 W/m <sup>2</sup>	50 W/m <sup>2</sup>	10 W/m <sup>2</sup>
FAR-3210(-BB) FAR-3310	RTR-105 (12 kW)	XN12CF	0.6 m	1.4 m	4.4 m
		XN20CF	0.4 m	0.9 m	3.0 m
		XN24CF	0.3 m	0.6 m	2.5 m
FAR-3220(-BB) FAR-3320	RTR-106 (25 kW)	XN12CF	1.3 m	2.7 m	9.5 m
		XN20CF	1.0 m	1.7 m	6.8 m
		XN24CF	0.7 m	1.3 m	5.5 m

\* XN12CF: 4 ft, XN20CF: 6.5 ft, XN24CF: 8 ft

**WARNING**

**Do not open the equipment unless totally familiar with electrical circuits and service manual.**

**ELECTRICAL SHOCK HAZARD**

Only qualified personnel are allowed to work inside the equipment.

**Construct a suitable service platform from which to install the antenna unit.**  
 Serious injury or death can result if someone falls from the radar antenna mast.

**Turn off the power at the mains switchboard before beginning the installation.**  
 Fire, electrical shock or serious injury can result if the power is left on or is applied while the equipment is being installed.

**Be sure that the power supply is compatible with the voltage rating of the equipment.**  
 Connection of an incorrect power supply can cause fire or damage the equipment.

**Use only the specified power cable.**  
 Fire or damage to the equipment can result if a different cable is used.

**Do not install the monitor unit, processor unit, power supply unit or control unit in a dusty environment, or one where the units may get wet from rain or water splash.**  
 Dust or water in the units can result in fire, electrical shock, or damage to the equipment.

**Attach protective earth securely to the ship's body.**  
 The protective earth (grounding) is required for the AC power supply to prevent electrical shock.

**CAUTION**

**Observe the following compass safe distances to prevent deviation of a magnetic compass:**

	Standard compass	Steering compass
Antenna Unit (12 kW)	2.15 m	1.40 m
Antenna Unit (25 kW)	2.45 m	1.60 m
Processor Unit (EC-3000)	2.40 m	1.55 m
Monitor Unit (MU-190)	1.65 m	1.05 m
Monitor Unit (MU-231)	0.85 m	0.55 m
Monitor Unit (MU-270W)	0.90 m	0.55 m
Radar Control Unit (RCU-025)	0.30 m	0.30 m
Trackball Control Unit (RCU-026)	0.30 m	0.30 m
Intelligent HUB (HUB-3000)	1.20 m	0.75 m
Sensor Adapter (MC-3000S)	2.05 m	1.35 m
Sensor Adapter (MC-3010A)	0.75 m	0.50 m
Sensor Adapter (MC-3020D)	1.05 m	0.70 m
Sensor Adapter (MC-3030D)	0.90 m	0.60 m
Switching HUB (HUB-100)	1.00 m	0.60 m
Power Supply Unit (PSU-014)	2.20 m	1.40 m
Junction Box (RJB-001)	1.10 m	0.70 m

**Note:** For more information, please refer to IMO SN/Circ.271 "Guidelines for the installation of shipborne radar equipment."

# SYSTEM CONFIGURATION

## NOTICE

The radar(s) must be interconnected to the following type approved sensors:

- EPFS meeting the requirements of the IMO resolution MSC.112(73).
- Gyrocompass meeting the requirements of the IMO resolution A.424(XI).
- SDME meeting the requirements of IMO resolution MSC.96(72).

The radar may be interconnected via HUB-3000 to other FURUNO processing units having approved LAN ports.

### Standard connection

Basic configuration is shown with solid line.

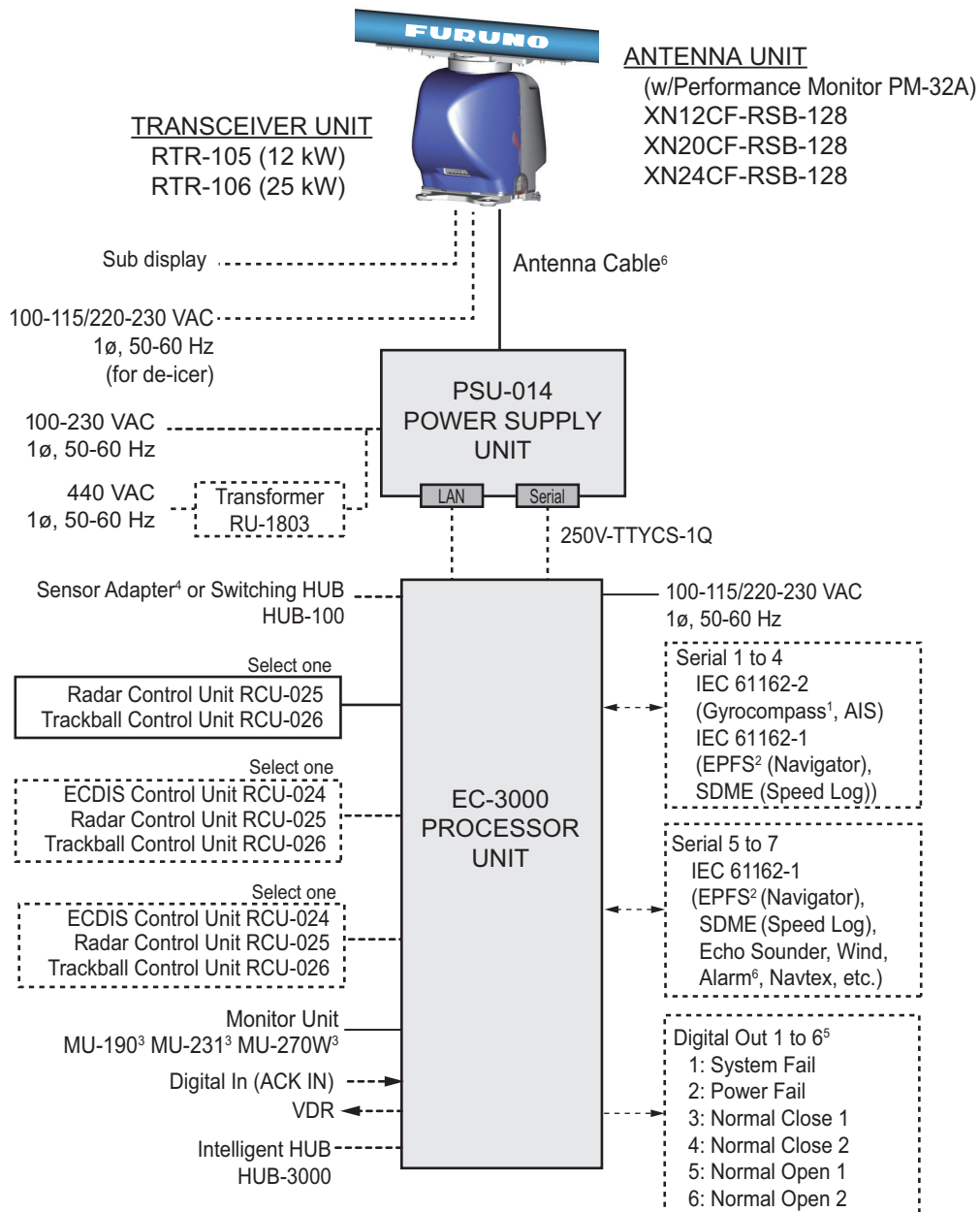

See the next page for footnotes.

## SYSTEM CONFIGURATION

### Category of units:

Antenna unit: Exposed to weather

Other units: Protected from the weather

### Notes

- 1) The gyrocompass must be type approved for compliance with IMO resolution A.424(XI) (and/or resolution A.821(19) for installation on HSC). The gyrocompass must also have an update rate that is adequate for the ship's rate of turn. The update rate must be better than 40 Hz (HSC) or 20 Hz (conventional vessel).
- 2) The EPFS must be type approved for compliance with IMO resolution MSC.96(72).
- 3) These monitors have been approved by the IMO, MU-190 for CAT 2C and CAT 2HC, MU-231/MU-270W for CAT 1C and CAT 1HC. If a different monitor is to be used on IMO vessels, its effective diameter must meet the Category requirements mentioned above.
- 4) The sensor adapters are Control Serial MC-3000S, Analog IN MC-3010A, Digital IN MC-3020D and Digital OUT MC-3030D.
- 5) Characteristics of contact output for Alarm:
  - (Load current) 250 mA
  - (Polarity) Normally Open: 2 ports, Normally Close: 2 ports
  - Serial I/O for alarm is also possible, which complies with IEC 61162-1.
- 6) Junction boxes are required for antenna cable length greater than 100 m. Max. cable length is 400 m.

**Interswitch connection**

When multiple radars are used, connect the units as shown in the figure below. This configuration lets each radar as a standalone radar in case of HUB malfunction.

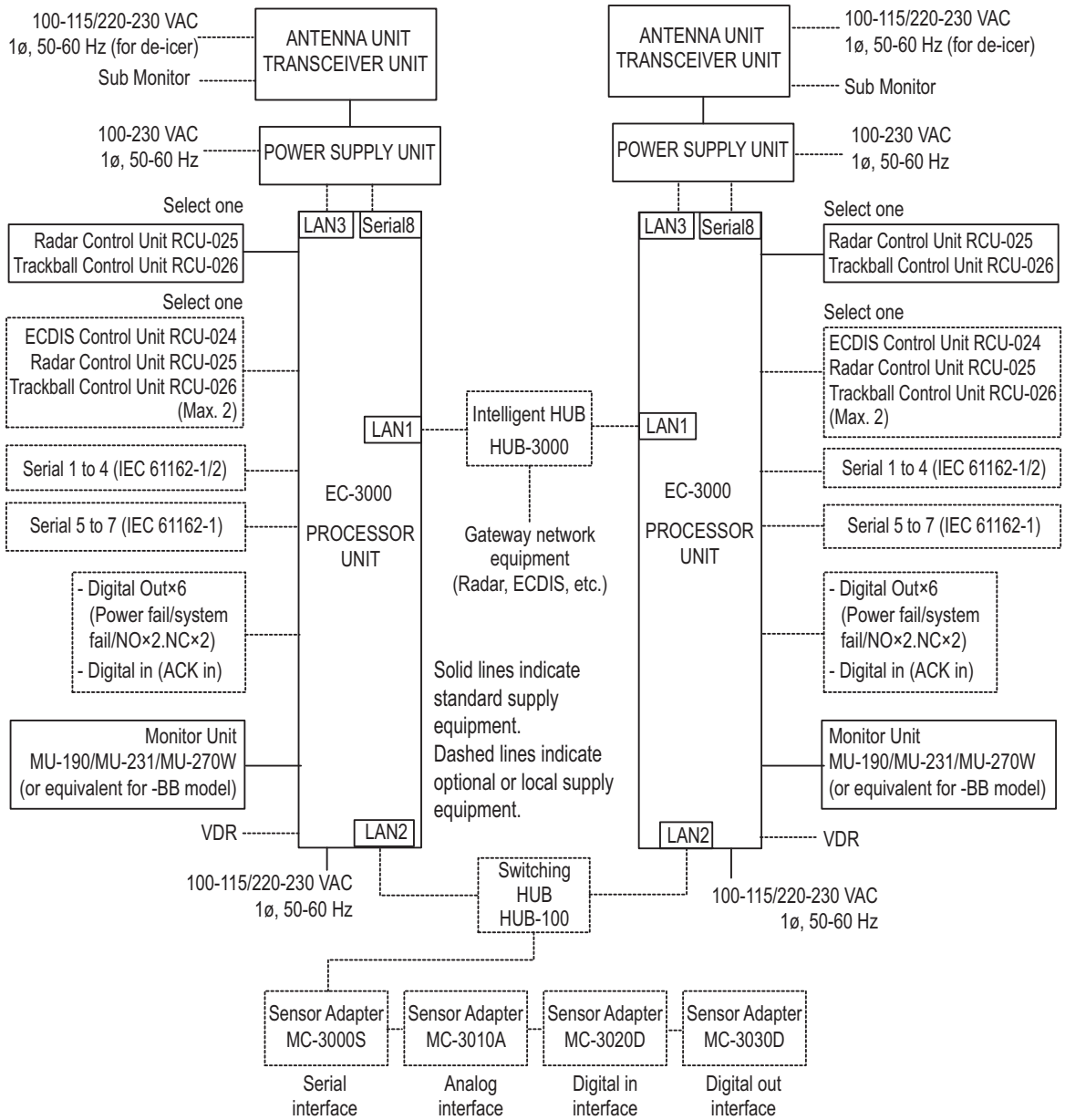

**Radar Component Combinations**

RADAR MODEL	ANTENNA UNIT	TRANSCEIVER UNIT	POWER SUPPLY UNIT
FAR-3x10 FAR-3x20	XN12CF-RSB-128 XN20CF-RSB-128 XN24CF-RSB-128	RTR-105 RTR-106	PSU-014
FAR-3x20W	XN20CF-RSB-130 XN24CF-RSB-130	RTR-108	
FAR-3x30S FAR-3x30SW	SN36CF-RSB-129 SN36CF-RSB-131	RTR-107 RTR-109	
FAR-3x30S-SSD	SN36CF-RSB-133	RTR-111	PSU-016 PSU-018

# EQUIPMENT LISTS

## Standard supply

Name	Type	Code No.	Qty	Remarks
Antenna Unit	XN12CF-RSB-128-105	-	Select one	4 ft
	XN12CF-RSB-128-106	-		6.5 ft
	XN20CF-RSB-128-105	-		8 ft
	XN20CF-RSB-128-106	-		
	XN24CF-RSB-128-105	-		
	XN24CF-RSB-128-106	-		
Processor Unit	EC-3000	-	1	
Monitor Unit	MU-190	-	Select one	For FAR-32x0
	MU-231	-		For FAR-33x0
	MU-270W	-		
Control Unit	RCU-025	-	Select one	Standard type
	RCU-026	-		Trackball type
Power Supply Unit	PSU-014	-	1	
Installation Materials	CP03-35201	001-249-860	1	For radiator
	CP03-35401	001-507-920	Select one	For RSB, no deicer
	CP03-35403	001-507-930		For RSB, w/deicer
	CP03-35500 [15M]	000-024-096	Select one	For antenna unit, 15 m
	CP03-35510 [30M]	000-024-097		For antenna unit, 30 m
	CP03-35520 [40M]	000-024-098		For antenna unit, 40 m
	CP03-35530 [50M]	000-024-099		For antenna unit, 50 m
	CP03-35301	001-249-770	1	For PSU-014
	CP24-02120	000-024-925	1	For EC-3000
	CP24-02200	000-027-668	1	For RCU-025
	CP24-02300	000-027-673	1	For RCU-026
Accessories	FP24-00603	001-285-760	1	For EC-3000
	FP24-00701	001-418-340	1	For RCU-025
	FP24-00801	001-418-410	1	For RCU-026
Spare Parts	SP24-00601	001-170-660	1	For EC-3000 Fuse: FGMB-S 125V 10A PBF (000-157-470-10, 3 pcs.)
	SP24-00602	001-170-670	1	For EC-3000 Fuse: FGMB-A 250V 5A PBF (000-157-570-10, 3 pcs.)
	SP03-17641	001-249-740	1	For PSU-014 Fuse: FGBO-A 250V 7A PBF (000-178-084-10, 2 pcs.)
Hoist X-Band Antenna Instructions	C32-01302-*	-	1	



**Console type**

Name	Type	Code No.	Remarks
Display Unit	RCN-303	-	FAR-3210/3220
	RCN-304	-	FAR-3310/3320

**Optional supply**

Name	Type	Code No.	Remarks
Sensor Adapter	MC-3000S	-	Serial type
	MC-3010A	-	Analog IN
	MC-3020D	-	Digital IN
	MC-3030D	-	Digital OUT
LAN Signal Conv.	OP03-223-3	001-254-380	
Cable Extension Kit	OP03-224-3	001-254-410	With Junction Box RJB-001, LAN Signal Converter
Prog. Inst. Software	OP03-230	001-285-780	DVD-R
Deicer Kit	OP03-226	001-254-320	
Switching HUB	HUB-100	-	
Intelligent HUB	HUB-3000	-	
Control Unit	RCU-026	-	Trackball type
	RCU-024	-	ECDIS standard type
Monitor Unit	MU-190	-	For FAR-32x0
	MU-231	-	For FAR-33x0
	MU-270W	-	
Bracket Assembly	OP26-5	000-016-270	For MU-190
	OP26-15	001-116-730	For MU-231
	OP26-30	001-439-060	For MU-270W
Hood Assembly	OP26-6	001-080-930	For MU-190
	OP26-16	001-116-740-01	For MU-231
Hood Assembly (Rear)	OP26-33	001-439-110	For MU-270W
Flush Mount Kit	OP26-12	001-116-280	For MU-190
	OP26-17	001-116-750	For MU-231
Flush Mount Assembly (Rear)	OP26-31	001-439-070	For MU-270W
Connection Stand (27)	OP26-34	001-462-860	For MU-270W
Cable	OP24-32	001-188-300	USB cable between processor unit and control unit
Terminal Opener	OP24-33	001-188-850	
Transformer Unit	RU-1803	-	
	RU-3305-0	-	
	RU-5693	-	
	RU-6522	-	
	RU-5466-1	-	
Rectifier	RU-3424	-	AC220V
	RU-1746B-2	-	
Junction Box	RJB-001	000-083-355	
LAN Cable Assy.	MOD-Z072-050+	001-167-890-10	

## EQUIPMENT LISTS

Name	Type	Code No.	Remarks
AC/DC Power Supply Unit	PR-240	000-013-632	
Installation Materials	CP03-28900(10M)	000-082-658	LAN cable for sensor adapter
	CP03-28910(20M)	000-082-659	
	CP03-28920(30M)	000-082-660	
Installation Materials	CP24-02900(10M)	001-208-050	LAN cable for HUB-3000
	CP24-02910(20M)	001-208-060	LAN cable for HUB-3000
	CP24-02920(30M)	001-208-040	LAN cable for HUB-3000
Connector	CP03-28901	008-542-460	
Crimping Tool	CRIMPFOX 10S	001-206-920	For sensor adapters
Cable Assy.	DVI-D/D S-LINK 5M	001-132-960-10	Between processor unit and monitor unit, 5 m
	DVI-D/D S-LINK 10M	001-133-980-10	Between processor unit and monitor unit MU-190, 10 m
Cable Assy.	DSUB9P-X2-L5M	001-188-260	For monitor unit, 5 m
	DSUB9P-X2-L10M	001-188-270	For monitor unit, 10 m
Cable Assy.	DSUB9P-X2-L5M-WP	001-207-890	For monitor unit, 5 m, waterproof type
	DSUB9P-X2-L10M-WP	001-207-900	For monitor unit, 10 m, waterproof type
Cable Assy.	DSUB9P-X2-A-L5M	001-252-580	Brightness control cable for monitor unit, 5 m
	DSUB9P-X2-A-L10M	001-252-590	Brightness control cable for monitor unit, 10 m
Cable Assy.	DVI-BNCX5-L2000	001-204-150	For connecting a VDR
Cable Assy.	TET-16-045A-2(L5M)	000-194-754-10	For RCU-025, 5 m
	TET-16-045A-3(L10M)	000-194-755-10	For RCU-025, 10 m
	TET-16-045A-4(L20M)	000-194-756-10	For RCU-025, 20 m
	TET-16-045A-5(L30M)	000-194-757-10	For RCU-025, 30 m
	6TPSH-XH12X2-L5.0SP2	001-186-310-10	For RCU-026, 5 m
	6TPSH-XH12X2-L10SP2	001-186-320-10	For RCU-026, 10 m
	6TPSH-XH12X2-L20SP2	001-186-330-10	For RCU-026, 20 m
	6TPSH-XH12X2-L30SP2	001-186-340-10	For RCU-026, 30 m
Cable	MC1.5-W-L600	001-187-470-10	Between sensor adapters, 0.6 m
	MC1.5-W-L1000	001-187-480-10	Between sensor adapters, 1 m
	MC1.5-W-L2000	001-187-490-10	Between sensor adapters, 2 m
	MC1.5-W-L3000	001-187-500-10	Between sensor adapters, 3 m
Signal Cable Assy.	S03-92-15(8P)	001-259-890	For sub monitor, RW-00136, 15 m
	S03-92-30(8P)	001-259-900	For sub monitor, RW-00136, 30 m
	S03-92-40(8P)	001-259-910	For sub monitor, RW-00136, 40 m
	S03-92-50(8P)	001-259-920	For sub monitor, RW-00136, 50 m
Spare Parts	SP24-00801	001-235-520	For HUB-3000
Antenna Reinforcement Kit	OP03-257	001-507-730	
Operator's Manual	OME-36160-*	-	Hard copy manual, English
	OMJ-36160-*	-	Hard copy manual Japanese

Name	Type	Code No.	Remarks
Magnetron Replacement Instruction Manual	E32-01306-*	-	Hard copy manual, English
	J32-01306-*	-	Hard copy manual, Japanese

### **About the category sticker**

This radar meets the requirements in IEC62388 (Marine navigation and radiocommunication equipment and systems-Shipborne radar-Performance requirements, method of testing and required test results). Check the appropriate box on the sticker which is pre-attached to the processor unit, according to your radar's specification. Refer to the table shown below to confirm your category.

Comply with MSC.192(79)			
<input type="checkbox"/>	CAT 1C	<input type="checkbox"/>	CAT 1HC
<input type="checkbox"/>	CAT 2C	<input type="checkbox"/>	CAT 2HC
<i>Sticker for category</i>			

Category	Radar type	ANT. rotation speed
CAT 1C	FAR/3310/3320	24 rpm
CAT 1HC	Same models as above	42 rpm
CAT 2C	FAR/3210(-BB)/3220(-BB)	24 rpm
CAT 2HC	Same models as above	42 rpm

This page is intentionally left blank.

# 1. INSTALLATION

## NOTICE

Do not apply paint, anti-corrosive sealant or contact spray to coating or plastic parts of the equipment. Those items contain organic solvents that can damage coating and plastic parts, especially plastic connectors.

## 1.1 Antenna Unit

### 1.1.1 Installation considerations

- The antenna unit is generally installed either on top of the wheelhouse or on the radar mast, on a suitable platform. Locate the antenna unit in an elevated position to permit maximum target visibility.
- A line of sight from the antenna unit to the bow of the ship must hit the surface of the sea in not more than 500 m or twice the ship's length, depending whichever value is smaller, for all load and trim conditions.

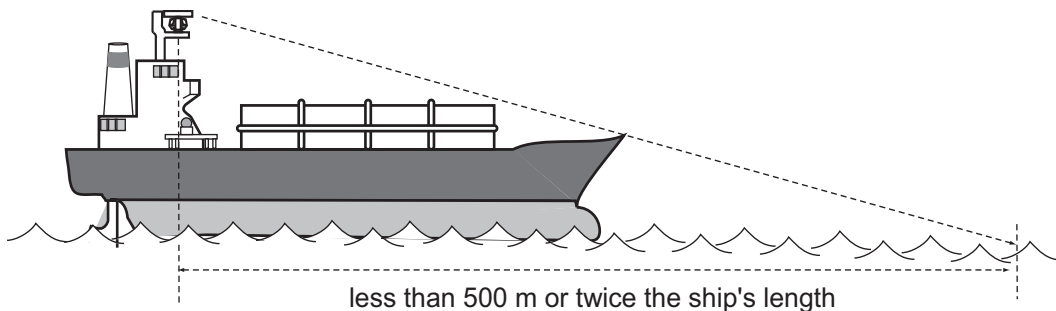

- Install the antenna unit so that any blind sectors caused by objects (mast, etc.) are kept to a minimum. A blind sector must not exist in arc of the horizon from right ahead to  $22.5^\circ$  aft of the beam to either side (see the figure below). Also, individual blind sectors of more than  $5^\circ$ , or the total arc of both blind sectors of more than  $20^\circ$ , must not occur in the remaining arc (Figure 2). Note that any two blind sectors separated by  $3^\circ$  or less are regarded as one sector.

Figure 1

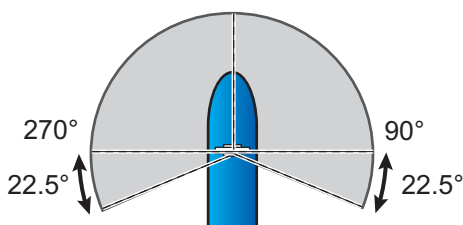
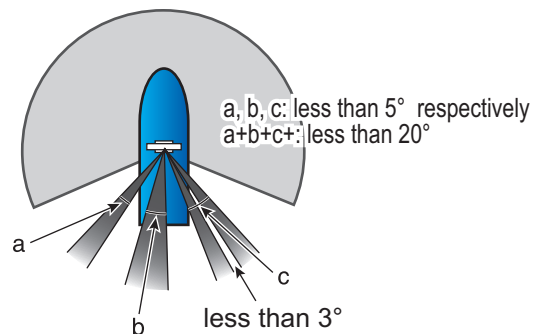

Figure 2



- Do not install the antenna where extreme winds may strike the port and starboard sides of the antenna.

## 1. INSTALLATION

- Install the antenna unit away from interfering high-power energy sources and TX radio antennas.
- Keep the lower edge of the antenna unit above the safety rail by at least 500 mm.
- Install two antenna units as shown in the right figure.
- No funnel, mast or derrick shall be within the vertical beamwidth of the antenna unit in the bow direction, especially zero degree  $\pm 5^\circ$ , to prevent blind sectors and false echoes on the radar picture.
- It is rarely possible to place the antenna unit where a completely clear view in all directions is available. Therefore, determine the angular width and relative bearing of any shadow sectors for their influence on the radar at the first opportunity after fitting.
- Locate the antenna of an EPFS clear of the radar antenna to prevent interference to the EPFS. A separation of more than two meters is recommended.
- A magnetic compass will be affected if the antenna unit is placed too close to the compass. Observe the compass safe distances on page ii to prevent interference to a magnetic compass.
- Do not paint the radiator aperture, to ensure proper emission of the radar waves.

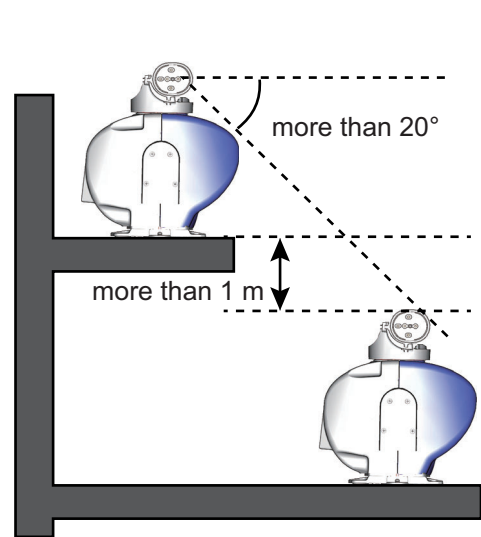

- Ground the unit with the ground wire (supplied).
- An antenna switch is provided on the chassis to stop the antenna. Make sure the mounting location provides easy access to the switch.
- Deposits and fumes from a funnel or other exhaust vent can affect the aerial performance and hot gases may distort the radiator portion. Do not install the antenna unit where the temperature is more than 55 °C.
- Leave sufficient space around the unit for maintenance and servicing. See the antenna unit outline drawing for recommended maintenance space.

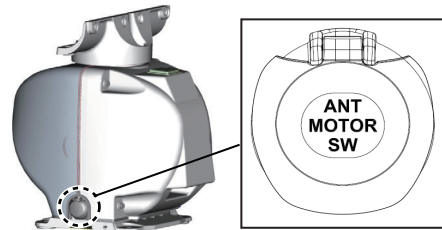

- If it is necessary to lay down the radiator before you fasten it to the antenna unit, lay it down with the waveguide up, to prevent damage to the cylinder that surrounds the waveguide.

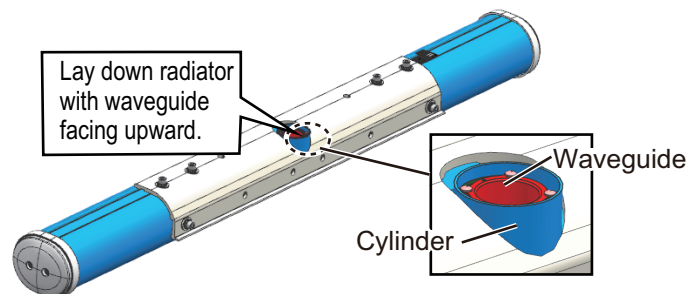

- If the de-icer is installed, a two-pole breaker (supplied locally) must also be installed.

**Note:** For more information, please refer to IMO SN/Circ.271 "Guidelines for the installation of shipborne radar equipment."

### 1.1.2 How to assemble the antenna unit

The antenna unit consists of the antenna radiator and the antenna unit chassis, and they are packed separately. Fasten the antenna radiator to the antenna unit chassis as follows:

1. Coat the hatched area shown below with the supplied adhesive.

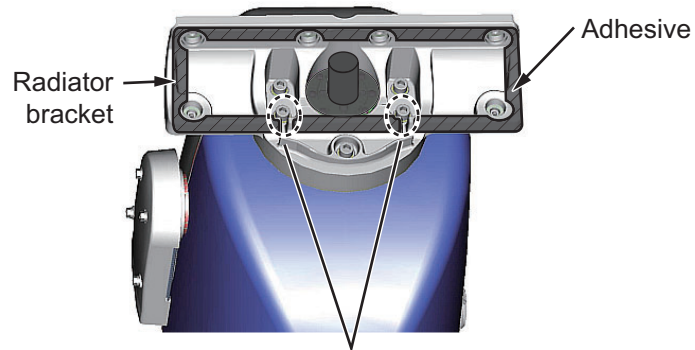

Do not apply the adhesive to these locations.

2. Remove the protective waveguide cap from the waveguide on the radiator bracket.

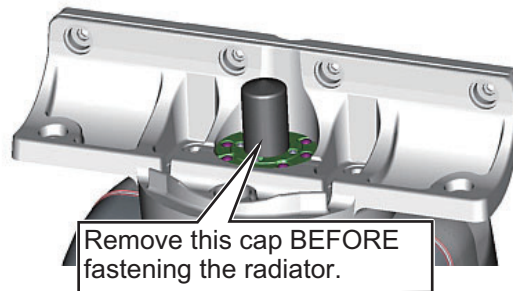

3. Coat the threads of six hex bolts (M8×50, supplied) with the supplied adhesive. Set the radiator to the radiator bracket.

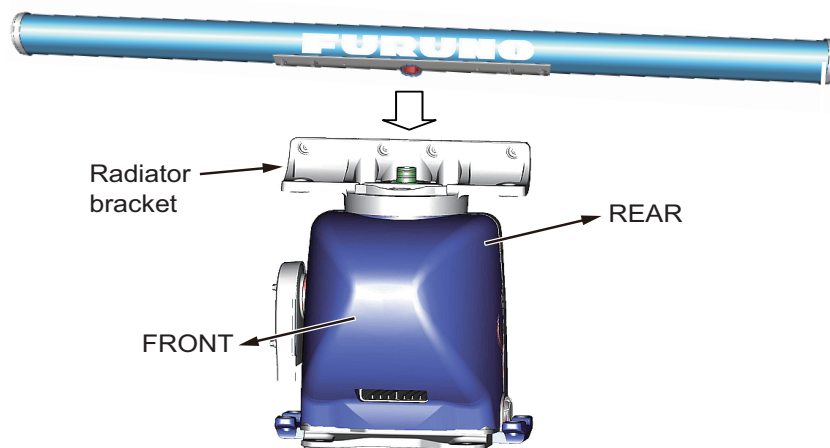

## 1. INSTALLATION

4. Fasten the antenna radiator to the radiator bracket with the six sets of hex bolts, flat washers (2 pcs.) and gaskets. **Fasten the bolts in the order shown below.** The torque must 15.0 N•m. Then, Coat the screws fixed at step 4 with the supplied adhesive as shown in the figure below.

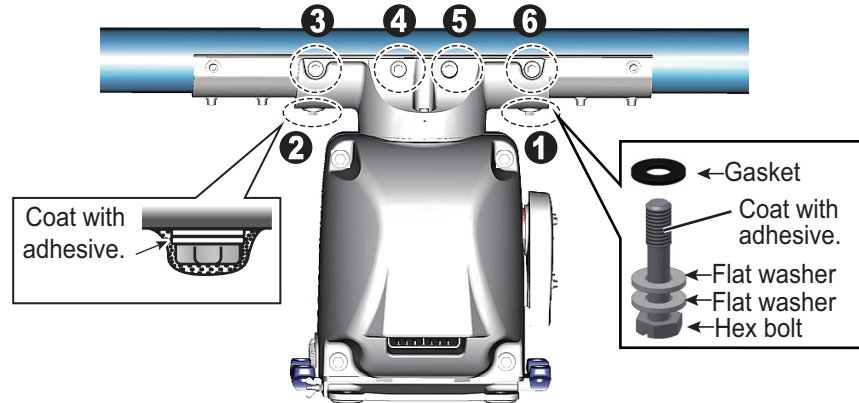

### 1.1.3 How to fasten the antenna unit to the mounting platform

The antenna unit may be assembled before hoisting it to the mounting platform. Hoist the antenna referring to the illustration below and "FAR-3xx0 Series X-band Antenna Unit Installation Notices," issued separately.

### How to Hoist the Antenna Unit

Do one of the following to hoist the antenna unit.

**Method 1**

**OK** Belt sling  
Antenna Support  
Set belt slings to radiator bracket.

**NG**  
This is NG because belt slings are not on the radiator brackets.

**Method 2**

Fasten belt sling to a shackle, pass belt sling around antenna support and fasten other end of belt sling to other shackle.

Belt sling  
Lifting fixture (ø20)  
Shackle (left, right)  
Bow side UP  
Radiator bracket  
Pass belt sling around radiator bracket.



- Construct a suitable mounting platform referring to the outline drawing at the end of this manual.

**Note:** The mounting platform must be flat, level and firmly secured.

- The diameter of the mast for fixing the antenna unit platform must be be over 180 mm.
- The thickness of the antenna unit platform must be over 12 mm.
- The reinforcement rib must be installed diagonally.

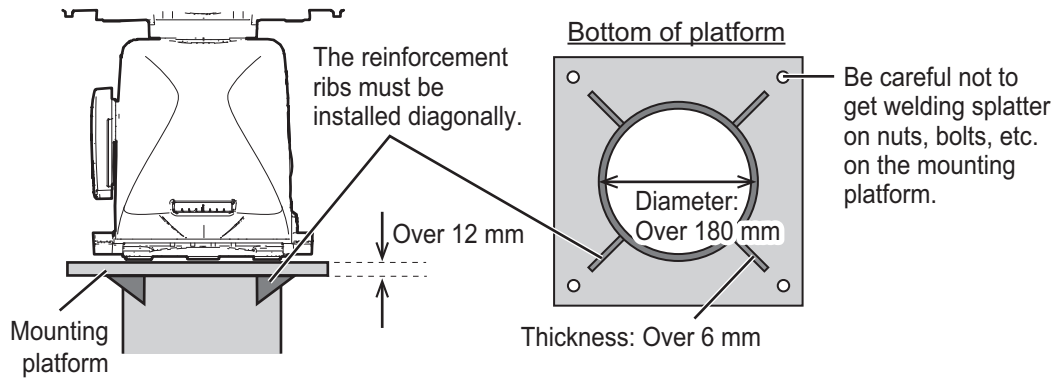

- Referring to the outline drawing, drill four mounting holes ( $\phi 15$  mm) in the mounting platform.
- Place the antenna unit on the platform, then orient the unit so the bow mark on its base is facing the ship's bow.

**Note:** When the antenna unit is placed on the platform, make sure that the platform is not inclined.

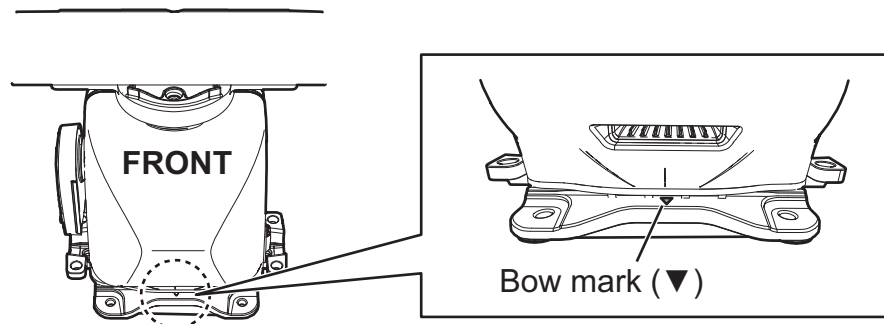

- Insert four sets of hex bolts (M12×70) attached the seal washers to the mounting holes of the antenna chassis. Lift the antenna chassis slightly then insert the bolts attached the insulation sheets.

**Note:** DO NOT insert the bolts from the underside of the platform. The cover cannot be opened.

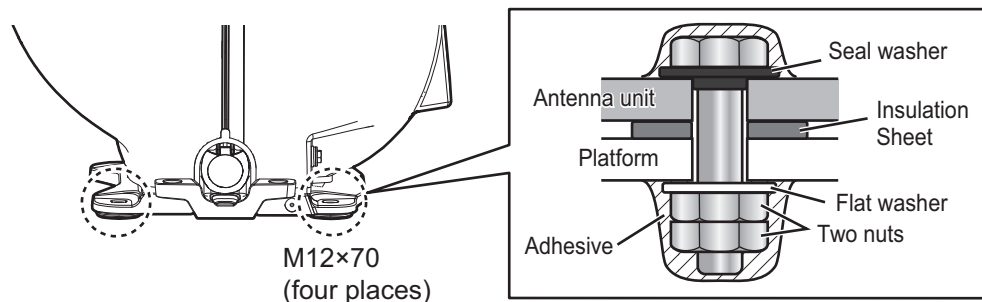

- Adjust the direction of the antenna unit so the bow mark on its base is facing the ship's bow.

## 1. INSTALLATION

- Fasten the antenna unit to the mounting platform with four sets of hex bolts (M12×70), nuts, flat washers and seal washers. Insert the bolts from the topside of the platform. The torque must be 49 N·m. For how to fasten double nuts, see the following procedure.

### How to fasten double nuts

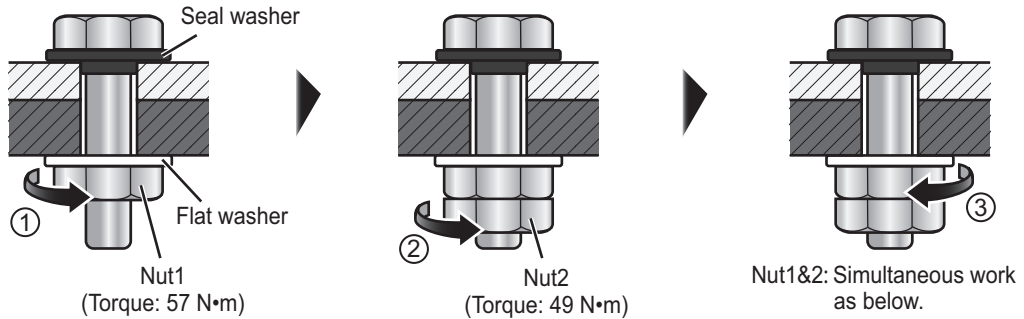

**Note:** Fasten the double nuts as shown in the figure to the right. Use spanners with a length of approx. 200 mm.

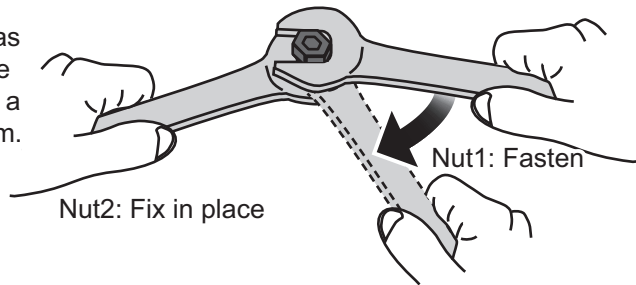

- Using a hex bolt (M6×25), nut (M6) and flat washer (M6), establish the ground system on the mounting platform. The location must be within 340 mm of the ground terminal on the antenna unit. Connect the ground wire (RW-4747, 340 mm, supplied) between the grounding point and ground terminal on the antenna unit. Coat the hardware of the ground system with the supplied adhesive.

### Antenna chassis side

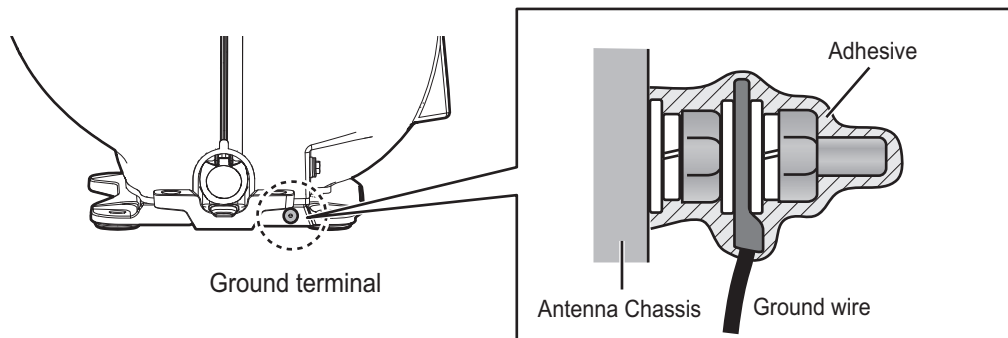

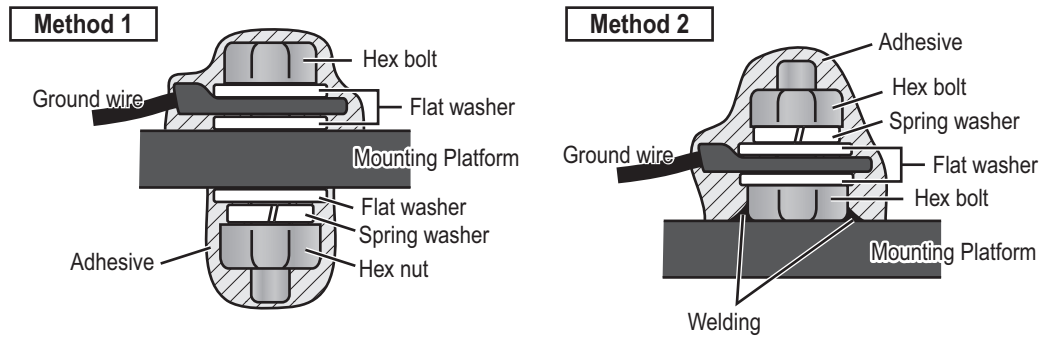
**Mounting platform side**

## 1.2 Monitor Unit

See the operator's manual for MU-190 (OMC-44670), MU-231 (OMC-44690) or MU-270W (OMC-44930) for the installation procedure. Keep in mind the following points when selecting a location.

- Locate the monitor unit where no framing is installed immediately in front of the monitor.
- Locate the monitor where the display is easily visible in all ambient lighting conditions.

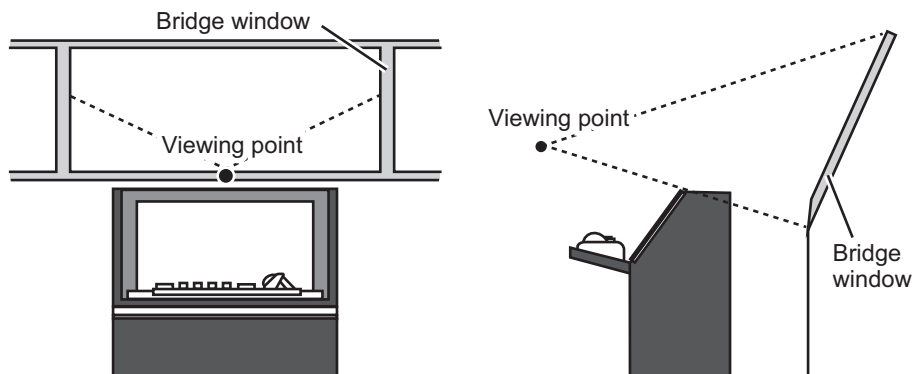

## 1.3 Radar Control Unit, Trackball Control Unit

The control units can be installed on a desktop or flush mounted in a console. For the desktop installation the unit can be laid flat or tilted.

**Installation considerations**

Keep in mind the following points when selecting a location.

- Select a location where the control unit can be operated easily.
- Locate the unit away from heat sources because of heat that can build up inside the cabinet.
- Locate the equipment away from places subject to water splash and rain.
- Leave sufficient space for maintenance and service, referring to the outline drawings at the back of this manual.

**Note:** The outline drawing number for RCU-024 and RCU-025 is different depending on the serial number, as shown below:

## 1. INSTALLATION

### For RCU-024:

- “199999” or earlier: See “C4473-G02” to “C4473-G04”.
- “200001” or later: See “C4473-G18” to “C4473-G20”.

### For RCU-025:

- “199999” or earlier: See “C3607-G01” to “C3607-G03”.
  - “200001” or later: See “C3607-G05” to “C3607-G07”.
- Determine the location considering the length of the signal cable between the control unit and the processor unit.
  - A magnetic compass will be affected if the control unit is placed too close to the magnetic compass. Observe the compass safe distances in the SAFETY INSTRUCTIONS to prevent interference to the compass.
  - Be sure to connect the ground wire (between the earth terminal on the chassis and the ship’s earth).
  - Fasten the USB cable with the cable tie.

*Ex. RADAR control unit, bottom view*

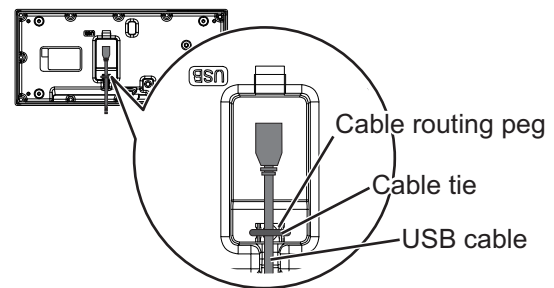

### 1.3.1 Desktop installation

#### How to mount the unit tilted

Use the desk fixing plate to mount the unit tilted.

1. Fix the desk fixing plate to the bottom of the control unit.
2. Fix the control unit with self-tapping screws (local supply).

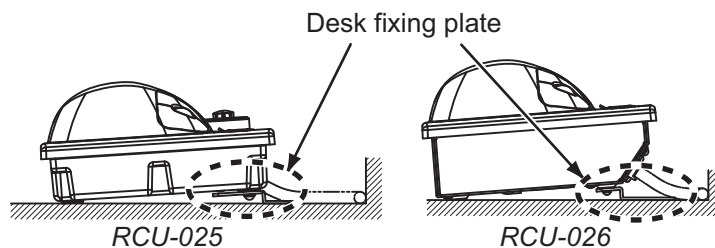

#### How to mount the unit flush with mounting surface

1. Drill four mounting holes of 5 mm diameter referring to the outline drawing at the back of this manual.
2. Fix the control unit with four screws (M4, local supply) from the underside of the desktop.

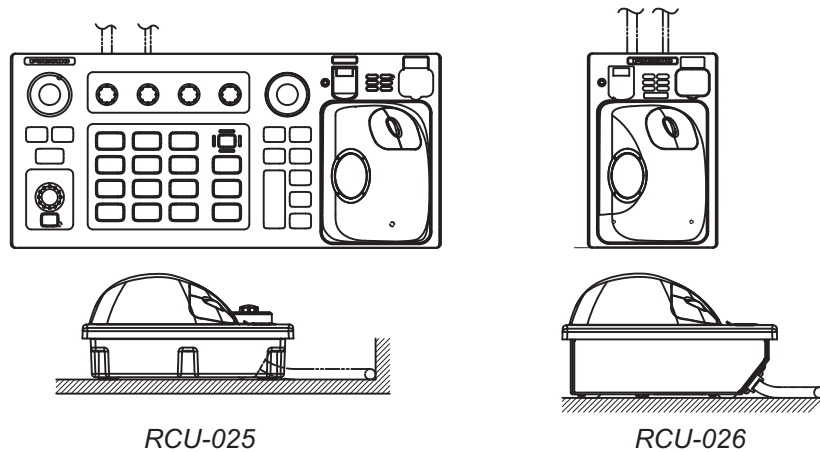

### 1.3.2 Installation in a console

Use the applicable optional flush mount kit to install the control unit in a console.

#### *Flush mount kit*

Control Unit	Type	Code
RCU-025	OP24-24	001-171-790
RCU-026	OP24-27	001-171-820

1. Prepare a cutout in the location as shown in the figure as below.

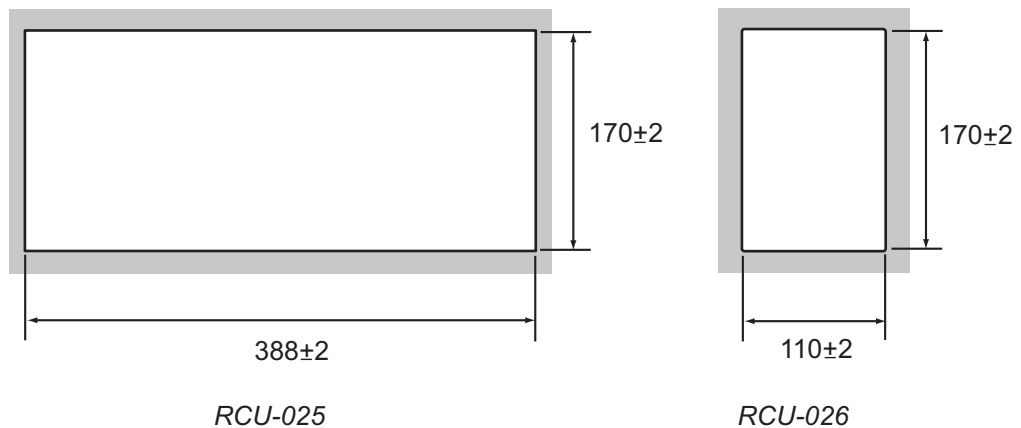

2. Set the control unit to the cutout.
3. Attach the mounting plate to the control unit with four screws from the rear side.
4. Screw the wing screw to each mounting plate and then insert hex. bolt to each wing screw.
5. Fasten each wing screw and then fasten the hex. nuts as shown in figure below.

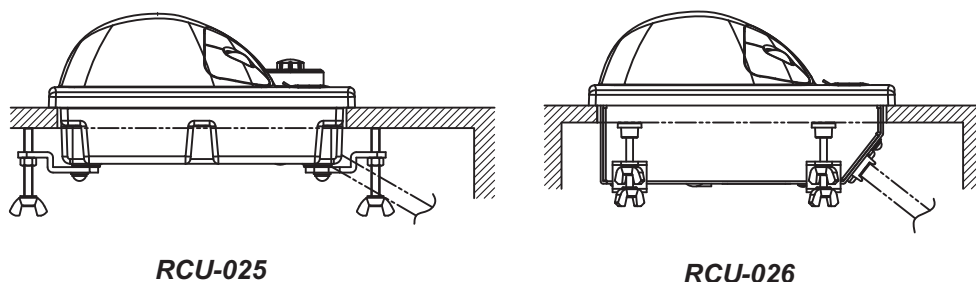

*Side view of control units*

## 1.4 Power Supply Unit

### 1.4.1 Installation considerations

The Power Supply Unit can be mounted on a bulkhead or deck. Keep in mind the following points when selecting a location.

- Locate the unit away from heat sources because of heat that can build up inside the cabinet.
- Select a location where the vibration is minimal.
- Locate the equipment away from places subject to water splash and rain.
- Make the service clearance of 100 mm in front of the vent hole (front and rear sides).

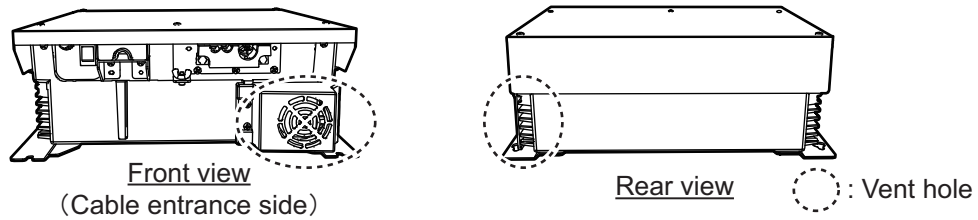

- Leave sufficient space at the sides and rear of the unit to facilitate maintenance.
- Connect the ground wire between the earth terminal on the chassis and the ship's earth.

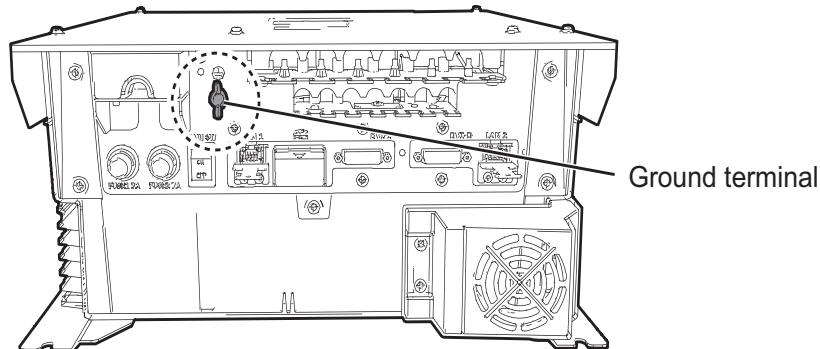

- A magnetic compass will be affected if the unit is placed too close to the magnetic compass. Observe the compass safe distances on page ii to prevent disturbance to the compass.

### 1.4.2 How to install the power supply unit

Use four bolts (M6, local supply) to fix the power supply unit.

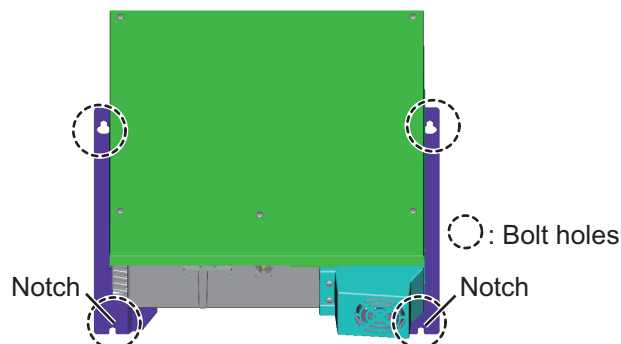

**Note:** For bulkhead mounting, the open notches on the unit must face the deck.

## 1.5 Processor Unit

### 1.5.1 Installation considerations

Keep in mind the following points when selecting a location.

- Locate the processor unit away from heat sources because of heat that can build up inside the cabinet.
- Select a location where the vibration is minimal.
- Locate the equipment away from places subject to water splash and rain.
- Make the service clearance of 100 mm in front of the vent hole (left side).
- Leave sufficient space at the sides and rear of the unit to facilitate maintenance.
- Be sure to connect the ground wire (between the earth terminal on the chassis and the ship's earth).
- A magnetic compass will be affected if the processor unit is placed too close to the magnetic compass. Observe the compass safe distances in the SAFETY INSTRUCTIONS to prevent interference to a magnetic compass.
- Leave the dummy plate fastened, to prevent the wrong operation of the power switch. The items behind the plate are for use by the serviceman.

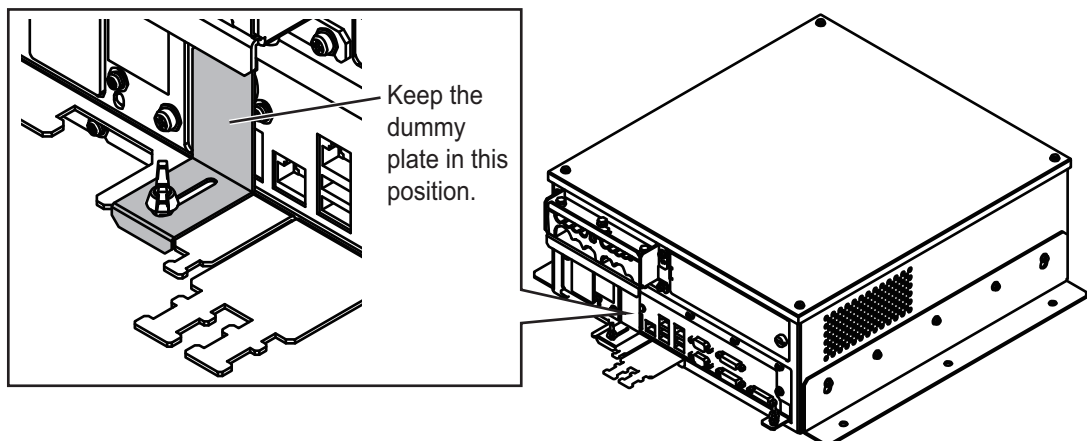

- Install the processor unit on the floor, or on a bulkhead with the following direction (horizontal), because of the DVD drive unit.

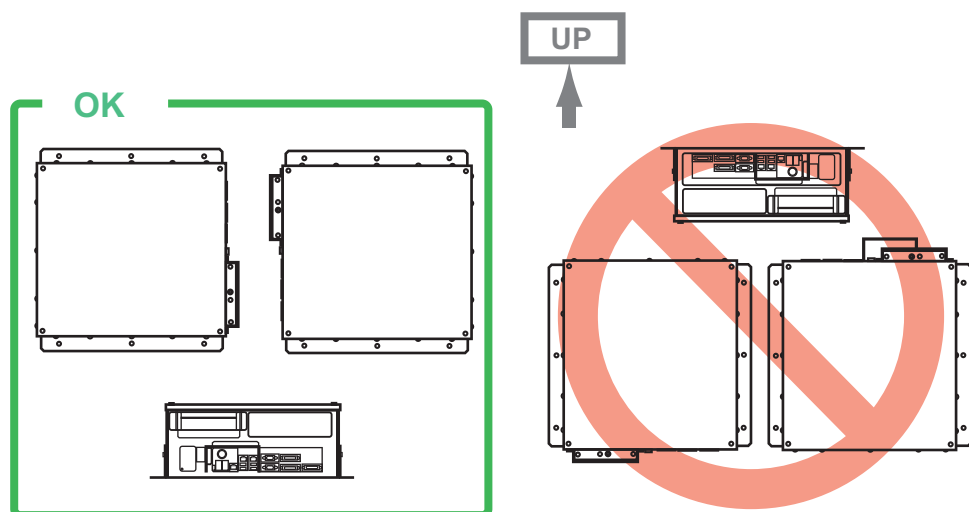

## 1.5.2 How to install the processor unit

1. Use 10 binding head screws (M4×8, supplied) to attach the chassis bases 1 and 2 to the processor unit.

**Note:** For bulkhead mounting, attach the chassis base 2 so that the notches on it are facing the deck.

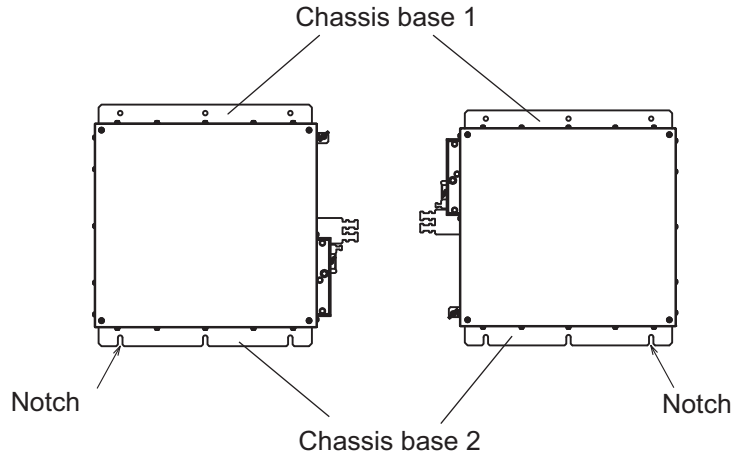

2. Use six bolts (M6, local supply) to fasten the processor unit.  
For bulkhead mounting, fasten three bolts for the lower bolt holes, leaving 5 mm of thread exposed from the bolt head. Set the notches of the processor unit on the three bolts, then fasten three bolts for the upper bolt holes. Then secure the processor unit in place with all six bolts fastened tightly.

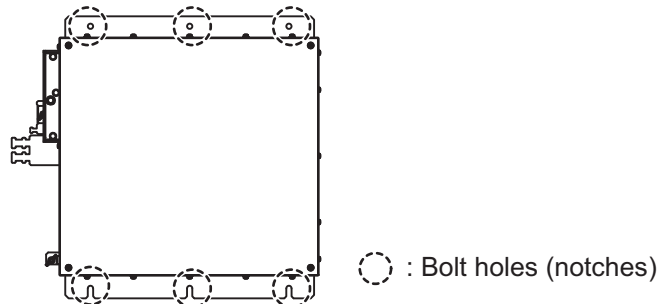

## 1.6 Sensor Adapters (option)

### Installation considerations

When you select a mounting location, keep in mind the following points:

- Locate the adapter away from heat sources because of heat that can build up inside the cabinet.
- Select a location where the vibration is minimal.
- Locate the equipment away from places subject to water splash and rain.
- Be sure to connect the ground wire (between the earth terminal on chassis and the ship's earth).
- Leave sufficient space at the sides and rear of the unit to facilitate maintenance.
- A magnetic compass will be affected if the adapter is placed too close to the magnetic compass. Observe the compass safe distances in the SAFETY INSTRUCTIONS to prevent interference to a magnetic compass.



- Select the location considering the number of sensor adapters connected.  
A maximum of eight MC-3000S can be connected to a sensor network.  
A maximum of 10 sensor adapters (MC-3010A/3020D/3030D) can be connected to a MC-3000S. However, note that five MC-3010A can be connected.
- For the MC-3000S, use a Cat5 cable.
- Select the location so that the length of the cables among the sensor adapters (MC-3000S, 3010A, 3020D and 3030D) is less than 6 m. If the length is more than 6 m, the adapters may not work properly.

### **How to install the sensor adapter**

1. Unfasten four pan head screws to remove the cover from the sensor adapter.
2. Fasten four self-tapping screws ( $\phi 4 \times 20$ , supplied) to fix the sensor adapter.
3. Reattach the cover.

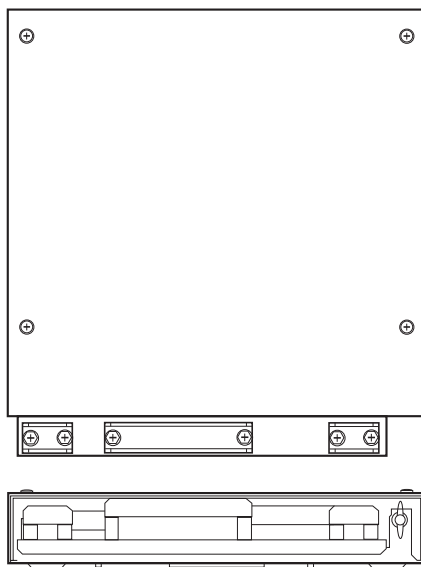

MC-3000S

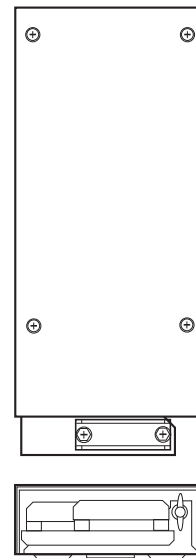

MC-3010A/3020D/3030D

## **1.7 Intelligent HUB (option)**

Use the optional Intelligent HUB (HUB-3000) to connect gateway network equipment. Do not connect this network to the shipborne LAN network. Further, do not connect a PC to this network, other than for maintenance.

### **Installation considerations**

Keep in mind the following considerations when selecting a location.

- Locate the hub away from heat sources because of heat that can build up inside the cabinet.
- Select a location where the vibration is minimal.
- Locate the hub away from places subject to water splash and rain.
- Be sure to connect a ground (between the earth terminal on the hub and the ship's earth).
- Leave sufficient space at the sides and rear of the unit to facilitate maintenance.

## 1. INSTALLATION

- A magnetic compass will be affected if the hub is placed too close to the magnetic compass. Observe the compass safe distances in the SAFETY INSTRUCTIONS to prevent interference to a magnetic compass.

### **How to install the HUB-3000**

1. Use two binding screws (M3×6, supplied) to attach the cable clamp (supplied) to the bottom of the HUB-3000.

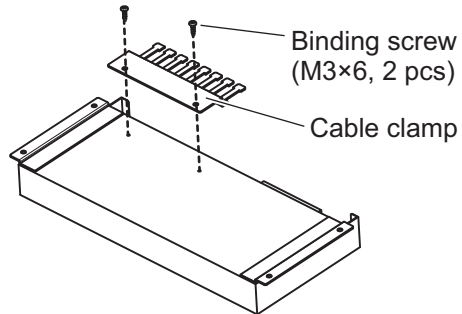

*HUB-3000, bottom view*

2. Fasten four self-tapping screws ( $\phi 4 \times 20$ , supplied) to fix the unit.

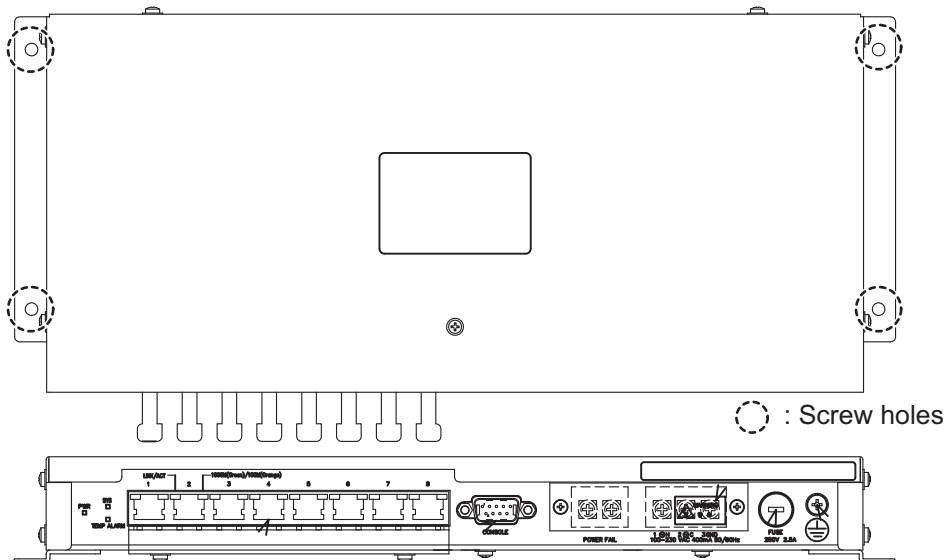

## 1.8 Switching Hub (option)

Use the HUB-100 to connect sensor networks. This network cannot be connected to the shipborne LAN network. Further do not connect a commercial PC to this network, other than for the maintenance.

For the installation procedures, see the operator's manual for HUB-100 (Pub. No.OMC-35191).

### **Installation considerations**

Keep in mind the following points when selecting a location.

- Locate the hub away from heat sources because of heat that can build up inside the cabinet.
- Select a location where the vibration is minimal.
- Locate the equipment away from places subject to water splash and rain.
- Make sure that the ground wire is connected between the earth terminal on the hub and the ship's earth.
- Leave sufficient space at the sides and rear of the unit to facilitate maintenance.
- A magnetic compass will be affected if the hub is placed too close to the compass. Observe the compass safe distances in the SAFETY INSTRUCTIONS to prevent compass malfunction.

## 1.9 Junction Box (option)

If the length of the antenna cable is more than 100 m, junction boxes are required. Install the boxes in a location protected from the weather, because their waterproofing standard is IPX3.

Fasten the junction boxes to the mounting location with four sets of M8 bolts and nuts. See the outline drawing for mounting dimensions.

## 1. INSTALLATION

This page is intentionally left blank.

# 2. WIRING

---

## 2.1 Overview

### Cabling considerations

To lessen the chance of picking up electrical interference, avoid where possible routing the antenna cable (power and LAN lines) near other onboard electrical equipment (radars, TX radio antennas, etc.). Also avoid running the cable in parallel with power cables. When crossing with other cable, the angle must be 90° to minimize the magnetic field coupling.

The antenna cable between the antenna and processor units is available in lengths of 15 m, 30 m, 40 m, and 50 m. Whatever length is used, it must be unbroken; namely, no splicing allowed. Use the antenna cable as short as possible to minimize attenuation of the signal.

The radar must be connected to an emergency power source, as required by SOLAS II-1.

### About network construction

- Use the optional Switching HUB (HUB-100) to connect the sensor networks. For the gateway networks, use the optional Intelligent HUB (HUB-3000).
- Do not connect the ship's LAN network to the optional HUBs. Also, commercial PCs cannot be connected to the gateway network, other than for maintenance.
- To connect the FEA-2xx7, FMD-32xx, FAR-2xx7, FCR-2xx9 via LAN network, use the INS network.
- This unit does not support IGMP snooping or CGMP enabled switch.
- This unit does not have a router or repeater hub function.
- The Switching HUB (HUB-100) does not support IGMP snooping or CGMP enabled switch.
- When you use IEC61162-450 compatible sensors, set [Transmission Group] on the [Common Installation Settings] menu. See the Instruction Manual (E32-01305-\*) for details.
- When connecting two or more FAR-2xx7 series radars, via the HUB-3000, to a FAR-3000 series radar, the HUB-3000 IGMP querier function must also be setup. See the Instruction Manual for the HUB-3000 IGMP querier.

### **About wiring**

- To use the USB port on the control unit, connect the control unit to the processor unit, using the USB cable supplied with the control unit or optional USB cable.
- The length of the USB cable must be within 5 m to prevent equipment trouble.
- The length of LAN cables must be within 50 m.
- Use the Cat5e or Cat6 LAN cable for the network if available locally.
- If LAN cables are not available locally, use the optional LAN cables (FR-FTPC-CY for sensor network, DTI-C5E350 VCV for gateway network).
- If extension or division of the DVI or RGB cables is necessary, use the dividers shown below.
  - DVI cable divider: DVI-12A (maker: IMAGENICS)
  - RGB divider: CIF-12H, DD-106 or WBD-14F (maker: IMAGENICS)
- Make sure that the ground wires are connected between the ground terminals on each equipment and the ship's earth.
- Pass the cables through the specified clamp or the locking wire saddle.
- If a UPS (user supply) is connected to this equipment, be sure that the grounding lamp does not light.
- The output from the UPS must be a sine wave, as in the right figure.

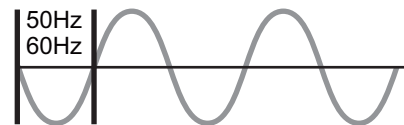

### **Standard wiring**

A Cat 5e LAN cable (RW-00135) connects between the antenna unit and the PSU. The maximum length of the cabling between the Processor Unit and the antenna unit is 80 m.

Retrofit (using antenna cable RW-9600) or foremast installation is also possible, with the installation of a pair of LAN Signal Converters, one in the antenna unit, the other in the PSU. See section 2.7.

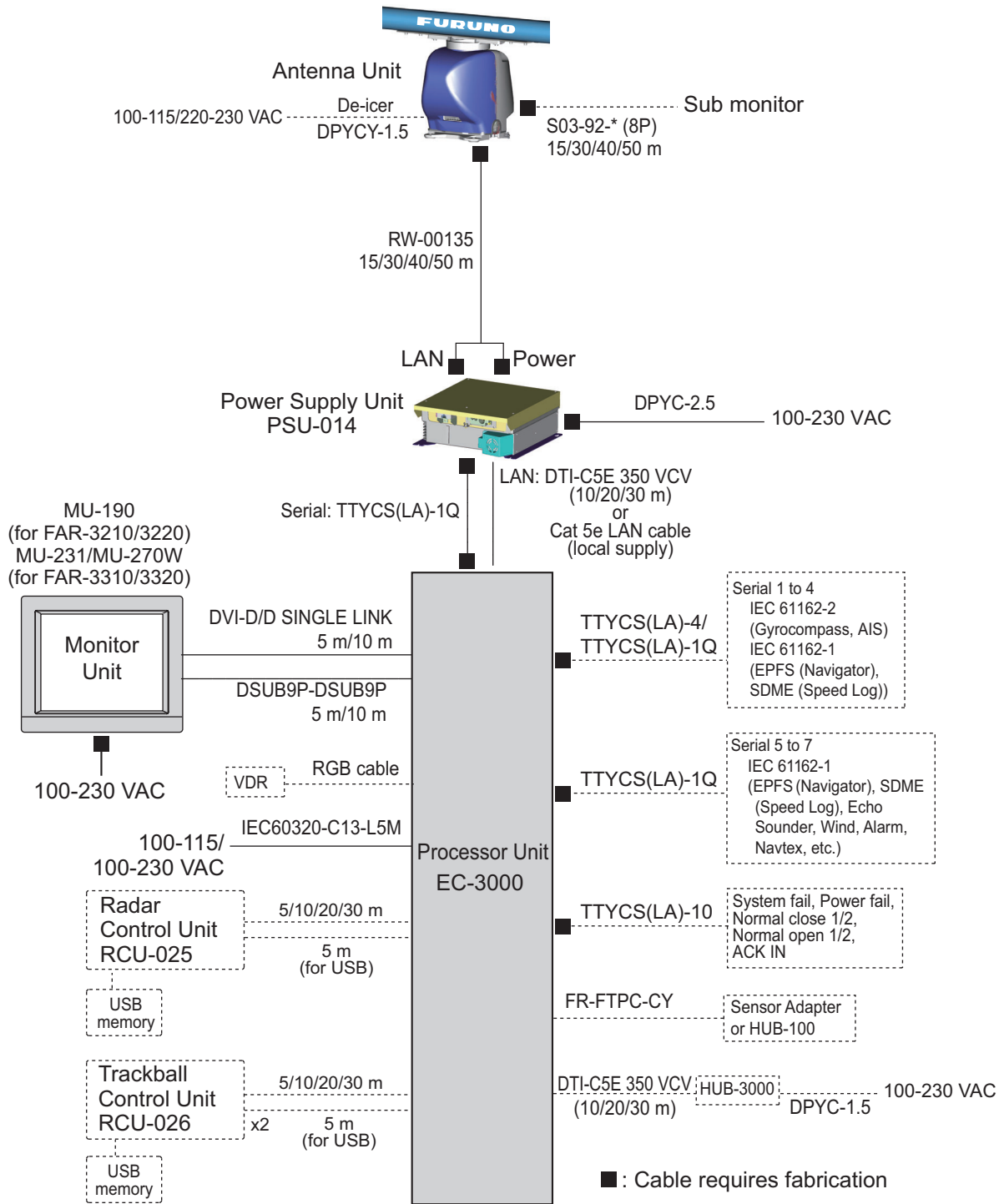

## 2.2 Antenna Unit

Three cables are connected to the antenna unit: antenna cable, cable for the sub monitor (option) and power cable for the deicer (option). The procedure shows how to connect all cables. Disregard the descriptions for the optional equipment if not applicable.

### 2.2.1 How to fabricate the cables

#### Antenna cable RW-00135

The end of the antenna cable RW-00135 which connects to the antenna unit is pre-fabricated.

#### Antenna cable RW-9600 (for retrofit or foremast installation)

The white, red, and green wires are not used. Attach a single crimp-on lug (FV5.5-S4(LF), yellow, supplied locally) to the wires. (These wires will be connected together with the shield of the power line, in the next section.)

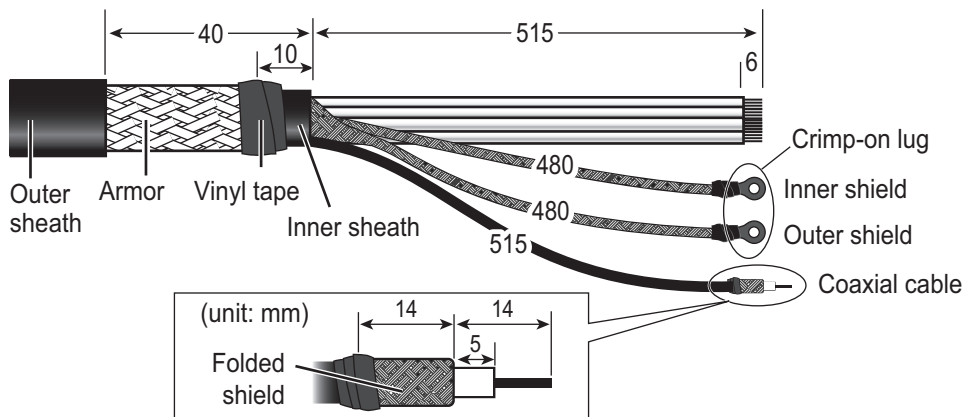

#### Cable RW-00136 (for a sub monitor)

**Note:** The maximum cable length is 50 m.

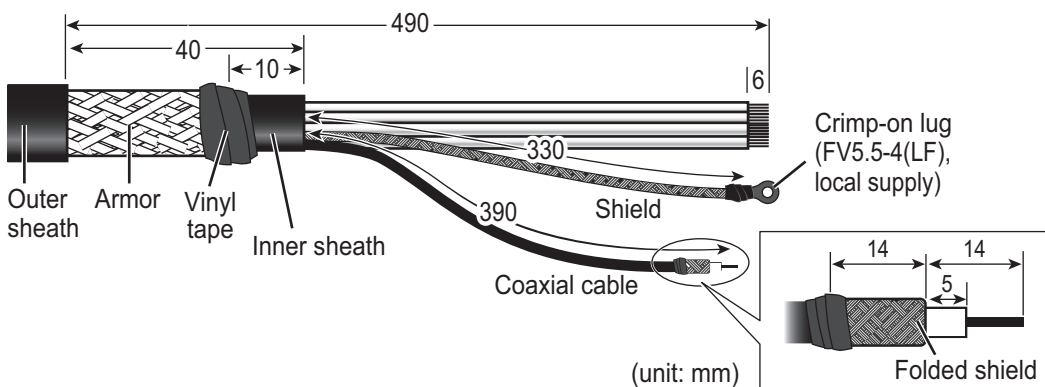

#### Cable DPYCY-1.5 (for the optional deicer)

- Before beginning any work on the antenna unit, turn off the breaker for the de-icer at the mains switchboard. (Turning off the display unit has no effect.)
- The neck of the antenna unit becomes VERY HOT when the de-icer is working. (The de-icer turns on when ambient temperature goes down to 5°C and heats to 55°C.)



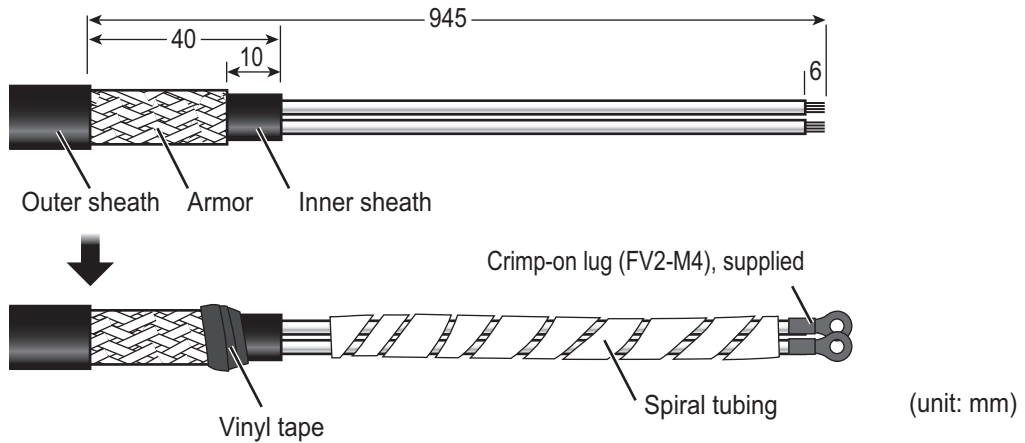

### 2.2.2 How to connect the cables

<b>NOTICE</b>	
<p>If there is a chance of inclement weather when the transceiver unit is removed, cover the intake on both covers with packing tape for waterproofing. Be sure to remove the tape after completing the installation.</p>	

Some parts or wiring have been omitted from the illustrations for clarity.

1. Unfasten four bolts from the rear cover to remove the rear cover. If the deicer is already installed or will be installed, remove two bolts inside the antenna to enable removal of the front cover. See Note 2.

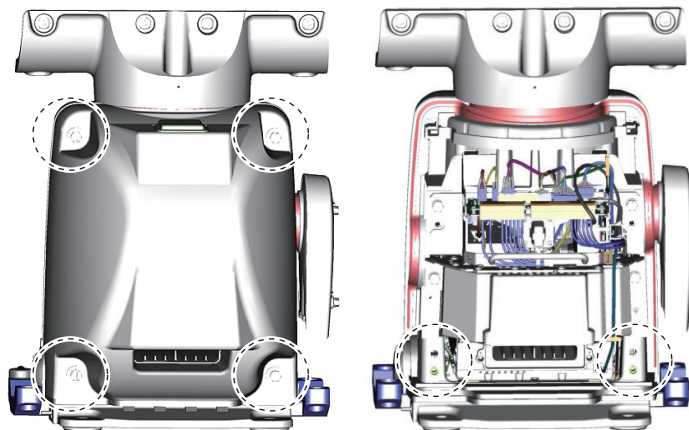

**Note 1:** The cable for the performance monitor is connected between the rear cover and the RF-TB Board in the antenna unit. Open the cover slowly to prevent damage to the cable and connector.

**Note 2:** If the deicer is to be installed, spread open the right and left heater elements on the cover, then remove the front cover, being careful not to hit the elements on the radiator or chassis.

**Note 3:** If this a retrofit or foremast installation, a LAN Signal Converter is required, in both the antenna unit and the power supply unit. See section 2.7.

## 2. WIRING

2. Disconnect the performance monitor connector (J807) and the motor drive connectors (J803, J804 and J808) from the RF-TB Board.

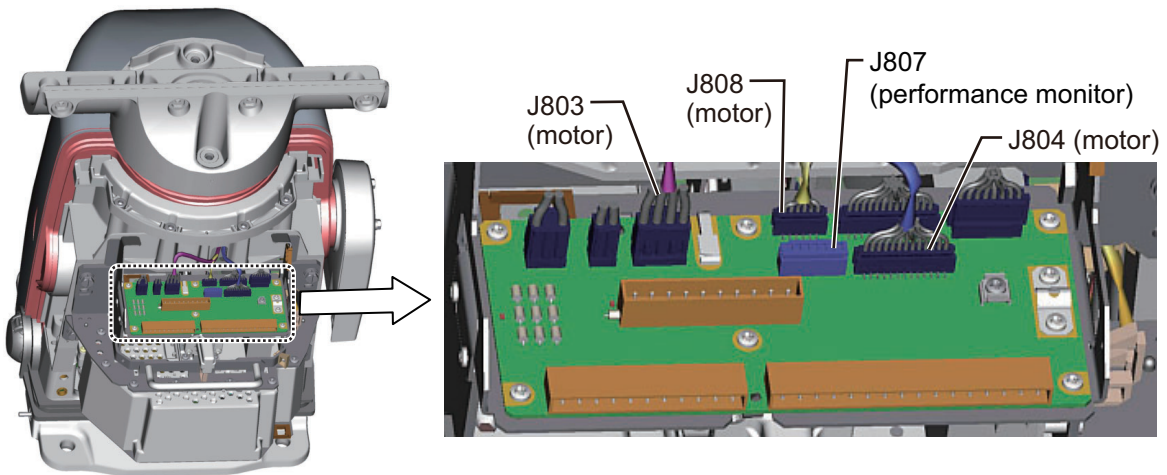

3. Unfasten the six bolts circled in the figure below to enable removal of the transceiver unit.

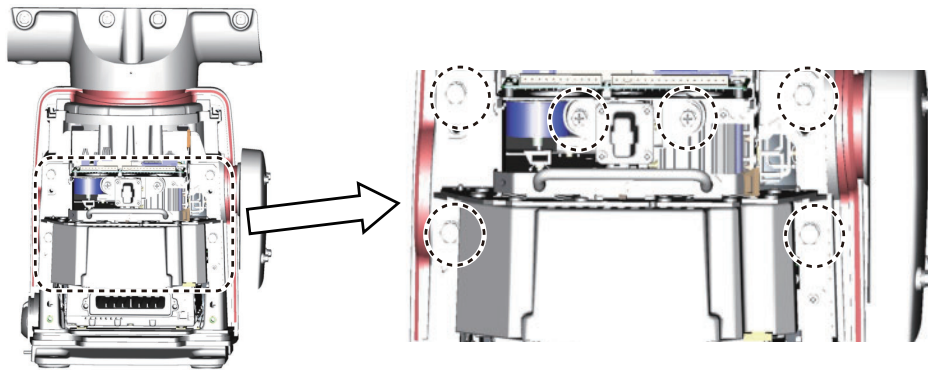

4. Pull the handle on the transceiver unit to remove the unit. **Lay the unit on its side or on top of non-ferrous material, to prevent demagnetization of the magnetron.**

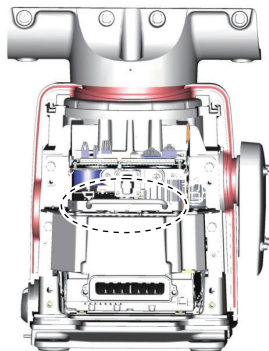

5. Unfasten four screws to open the cable entrance cover.

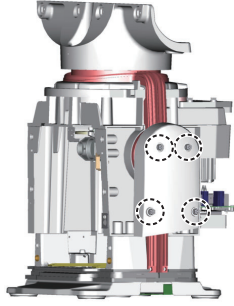

**Note:** The orientation of the cable entrance assy. can be changed, in one of the three orientations shown in the figure below. **No other orientation is allowed, to maintain watertight integrity.** The default orientation is "deck". To change the entrance, unfasten the four screws circled in the figure below, then orient the cable entrance assy. in the required direction. Refasten the screws.

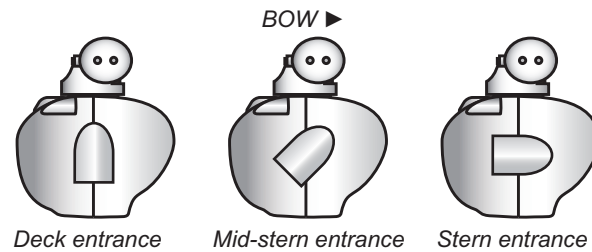

↓ TO CHANGE THE ORIENTATION:

Unfasten these screws to change the orientation of the cable entrance assy.



## 2. WIRING

6. Unfasten the four screws fixing the cable clamp plates (2 pcs.).

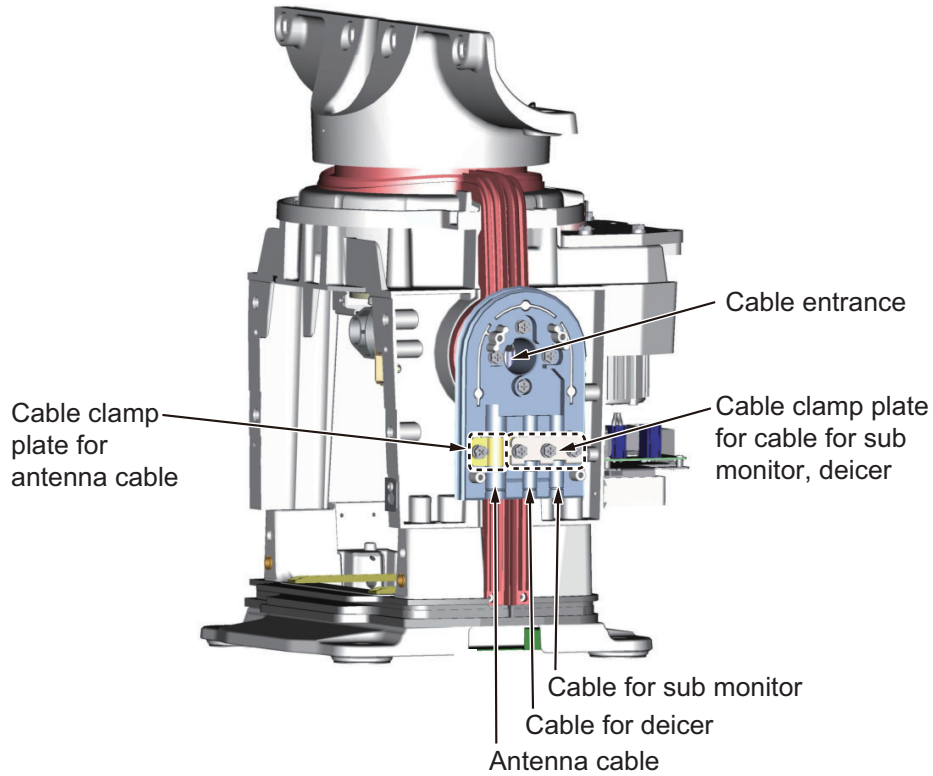

7. Pass the antenna cable through the cable entrance. If applicable, also pass the cable for the sub monitor and the power cable for the deicer through the cable entrance. Pass the cables through their respective locking wire saddles.

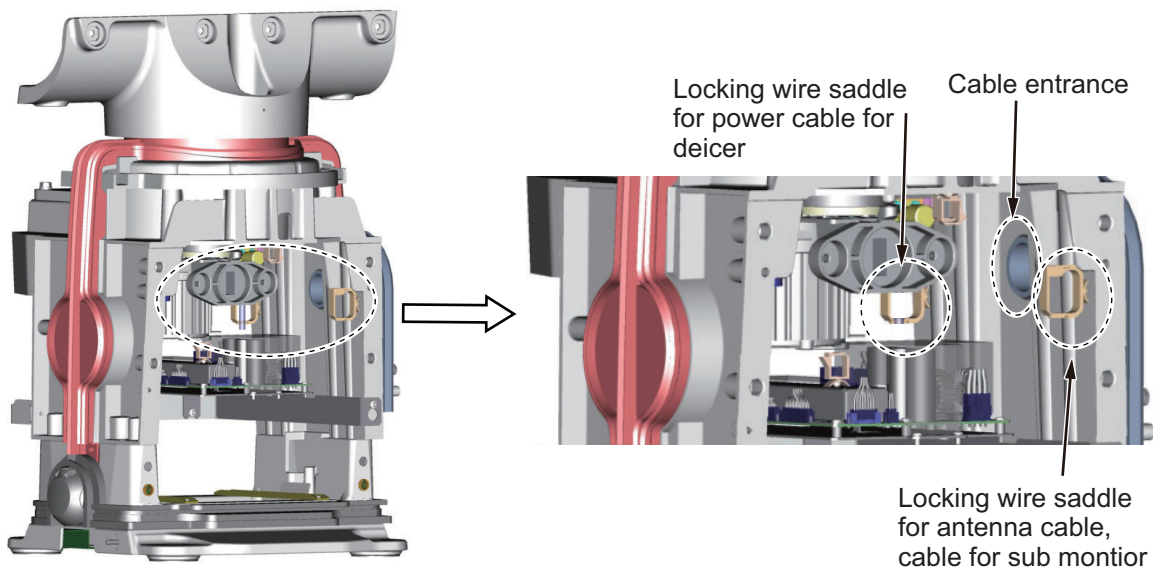

8. Re-mount the transceiver unit then reconnect the connectors for the motor (J803, J804 and J808).

9. Pass the LAN cable through the locking wire saddle at the bottom of the transceiver unit.

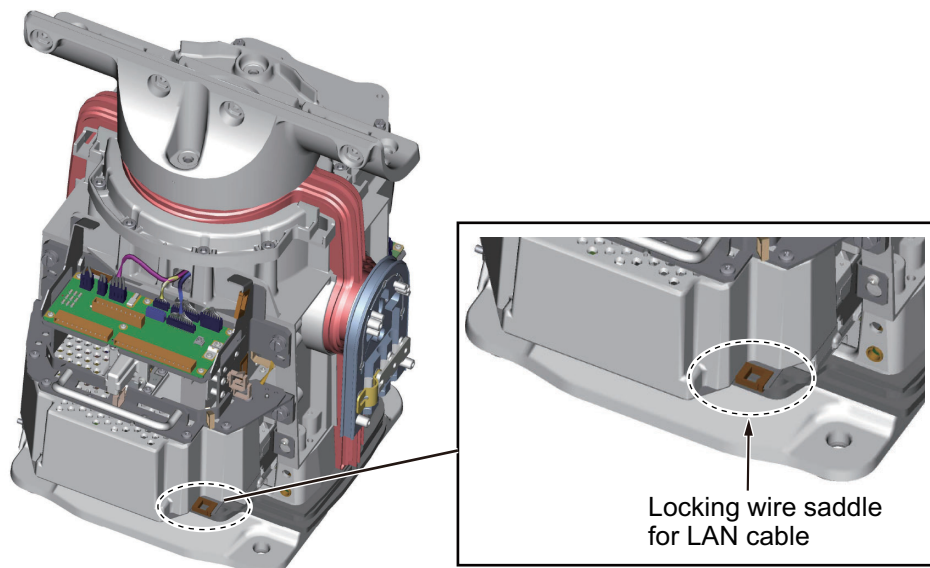

10. Connect the antenna cable and the cable for the sub monitor as shown below. See the illustration on the next page for parts location.

- Attach appropriate WAGO connector (supplied) to both the antenna cable and the cable for the sub monitor. Connect the antenna cable and the cable for the sub monitor to the RF-TB Board as shown below.

Antenna cable

**Power line:** TB801

**LAN cable:** J821

**Shield of power line:** Screw on fixing plate. See \*<sup>1</sup> in illustration on next page.

**Shield of LAN cable:** Screw above LAN cable port.

Cable for sub monitor

**Signal line:** TB803

**Shield:** Screw on fixing plate. See \*<sup>2</sup> in illustration on next page.

**Coaxial cable:** TB804

2. WIRING

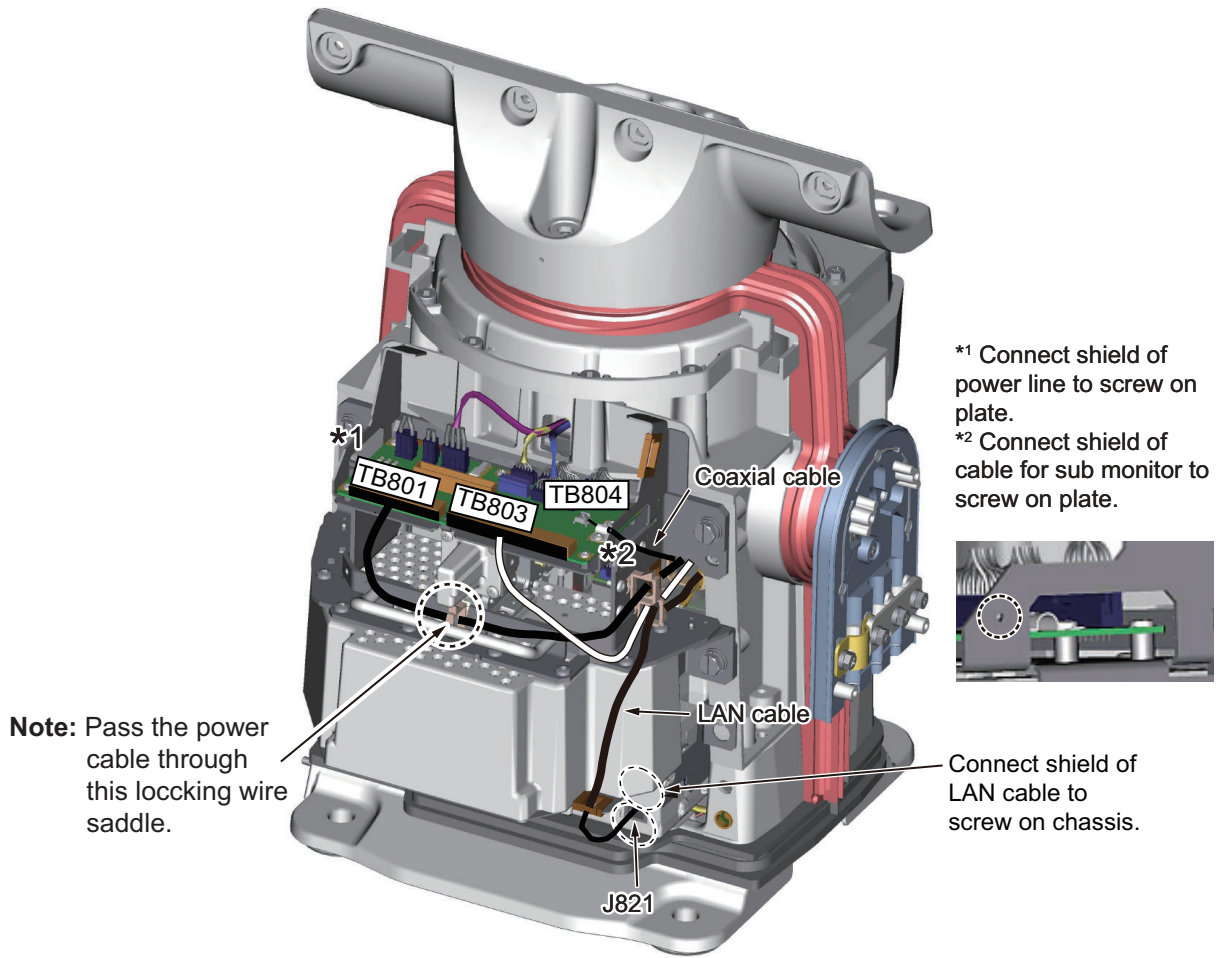

**POWER:** TB801 on RF-TB Board (03P9570)

Pin	1	2	3	4	5	6	7	8	9	10	11
Color	BRN	/	RED	/	/	ORG	YEL	GRN	BLU	PPL	WHT

**SIGNAL:** TB803 on RF-TB board

Pin	1	2	3	4	5	6	7	8	9	10	11	12	13	14	15	16
Color	/	/	/	/	/	/	/	/	/	/	BRN	RED	ORG	YEL	WHT	BLK

**How to connect wires to WAGO connector**

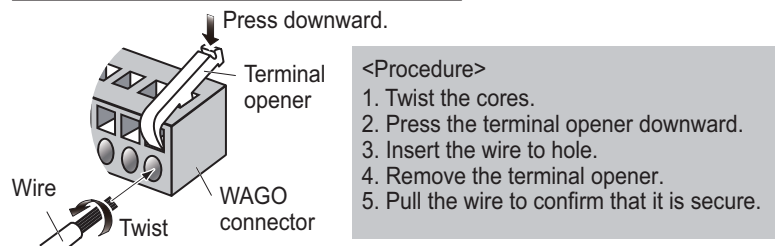

**COAXIAL CABLE:** TB804 on RF-TB board

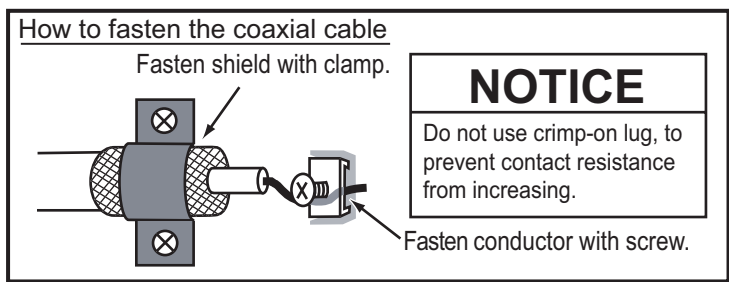

**Note 1:** A terminal opener is provided on the RF-TB Board.

**Note 2:** For the antenna cable RW-9600, connect the crimp-on lug (that binds unused wires) together with the shield of the power line. See \*1 on page 2-8 for the location.

11. **DE-ICER INSTALLATION.** If the de-icer is not provided, go to step 12.  
See also "X-band De-icer Kit Installation Instructions", issued separately, for the de-icer not fitted at the factory.

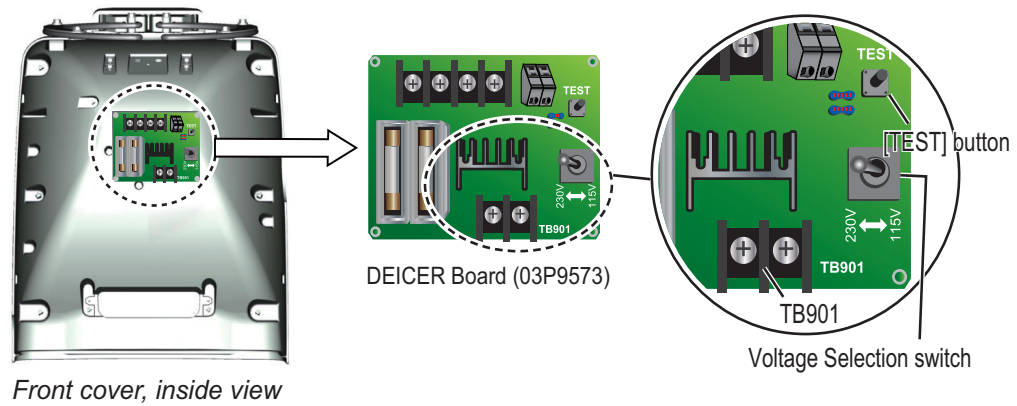

- 1) Set a locking wire saddle (supplied) at locations (2) and (3) shown below. Pass the power cable through the locking wire saddles (1), (2) and (3) and pull it to the front side.

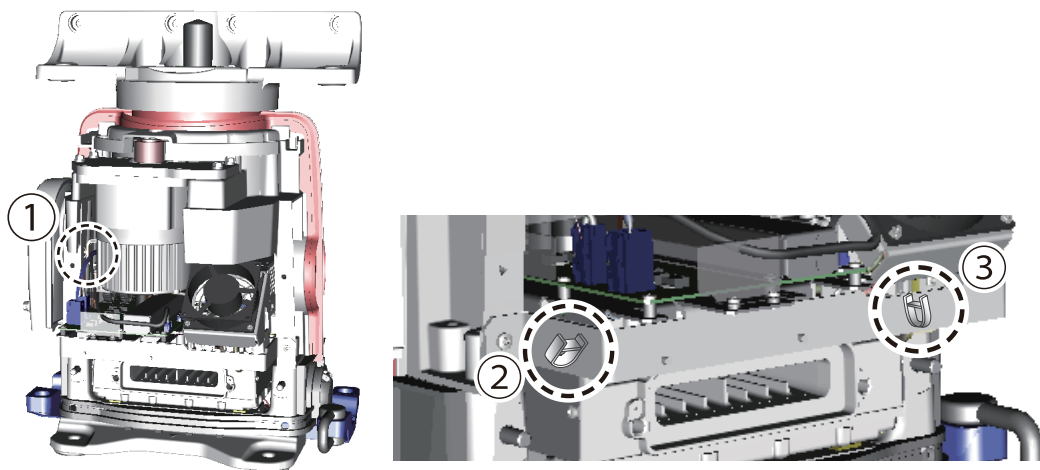

- 2) Unfasten the cable band\*. Pass the cable for the de-icer through the band then fasten the band. Connect the cable to TB901 on the DE-ICER board, using the crimp-on lugs supplied.

\* For the DE-ICER installation kit, unfasten the cable band on the cover supplied. (The original cover can be discarded.)

- 3) Set the Voltage Selection switch according to the power source for the de-icer; 115 V or 230 V.
- 4) Apply power to the deicer then press the [TEST] button about ten seconds. Check that the heater gets hot.

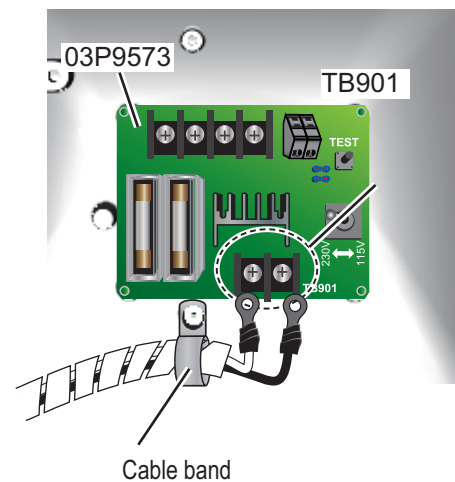

## 2. WIRING

- 5) Coat the gasket (all brims) of the intake with the supplied oil compound. Be sure to coat the gasket completely.

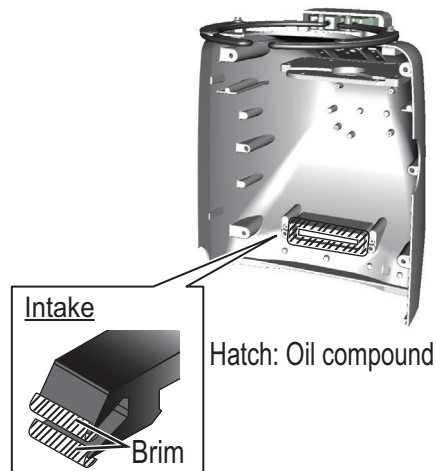

- 6) Set the front cover to the antenna unit. Take care not to hit the heater elements on the chassis or radiator.
- 7) Use M5 screws (supplied) to fasten the base of the heater. Fasten the installation materials shown in the following figure to each of the cover bolts.

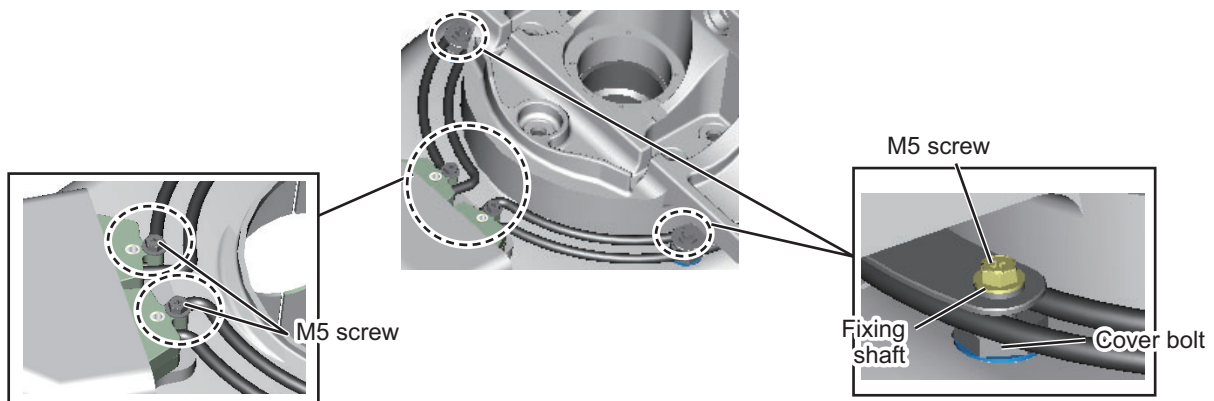

- 8) Attach the supplied earth label over the earth label currently attached near the grounding terminal.

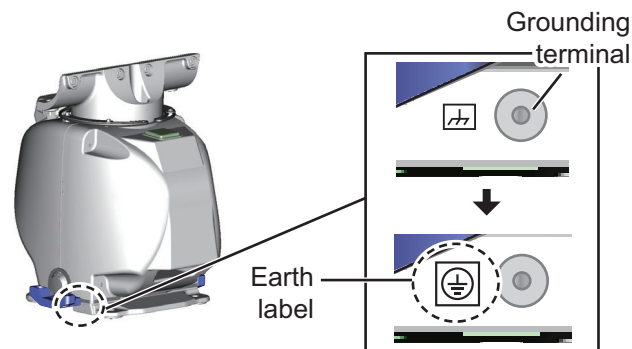

12. Position the cables so their armors lie beneath their respective cable clamp plates in the cable entrance. Fasten the plates.



13. Close the cable entrance cover as shown in the figure below.

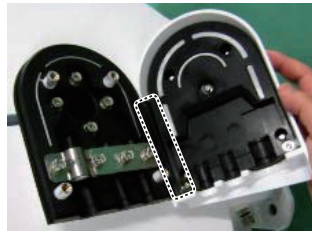

① Coat the hinge inside the gasket with adhesive, to prevent water from leaking into the cover.

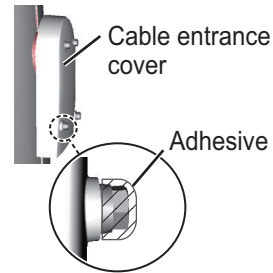

② Close cover then coat screw heads with adhesive.

14. Fix the cable cover with four screws, then coat the screws with adhesive.

15. Connect the performance monitor connector (J807) to the rear cover.

16. **Check that the gasket on the front and rear covers is seated properly**, then close the covers. The torque for the fixing bolts is 10.0 N•m.

**Note 1:** If it is necessary to open the front cover after installing the de-icer kit, remove the power cable from the locking wire saddle shown in the right figure then detach the cover slowly to prevent damage to the heater element.

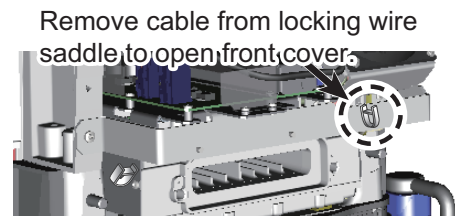

**Note 2:** Take care not to hit the heater elements on the chassis or radiator. If the heater hits something, unfasten the fixing screws for the heater to adjust the position of the heater. Then fix the heater again.

## 2.3 Processor Unit

**Note:** The interface ports approved for interconnecting navigation equipment are shown in the figure below. For details, see section 2.3.3 "How to select the serial input/output format".

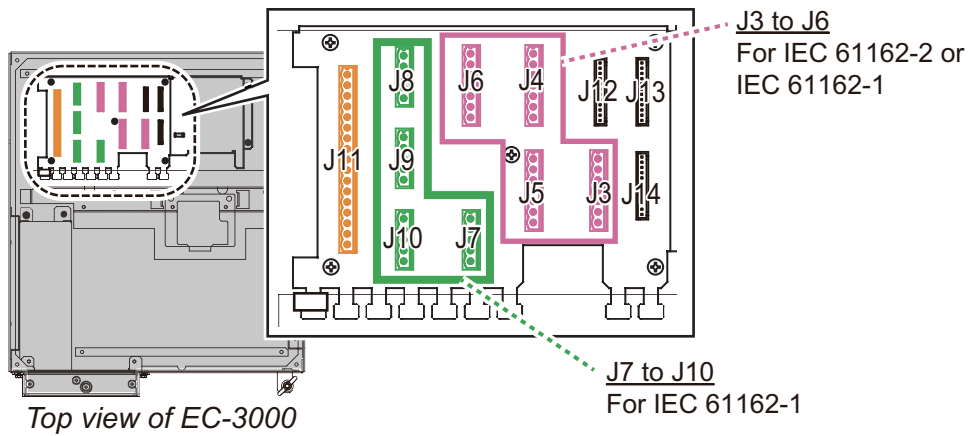

### 2.3.1 How to connect cables to terminals in the processor unit

Use screws (M3×6, supplied) to attach the wiring plate 1 and wiring plate 2 to the processor unit. Connect the cables shown below to the connectors at the front of the processor unit. Bind cables to the appropriate fixing metal with the cable ties (supplied).

For the cables from the monitor unit (type: DVI-D/D SLINK5M/10M (MU-190 only), DSUB9P-X2-L5/10M) and ground wire, connect them to the processor unit directly (without fixing to a wiring plate). Tighten the fixing screws on these connectors to prevent disconnection from the processor unit.

**Note:** Connect the cables so that they do not interfere with the opening or closing of the DVD tray.

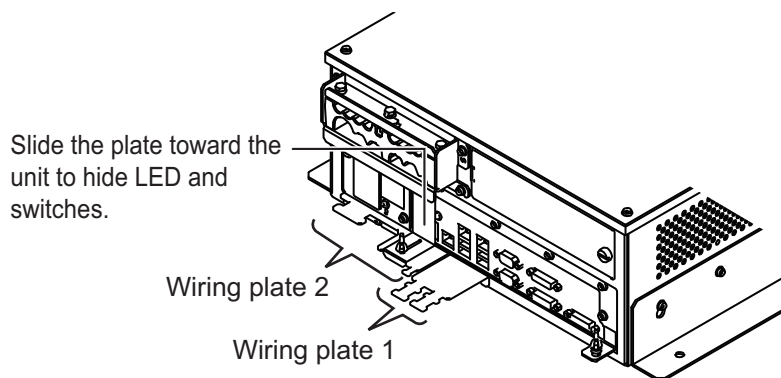

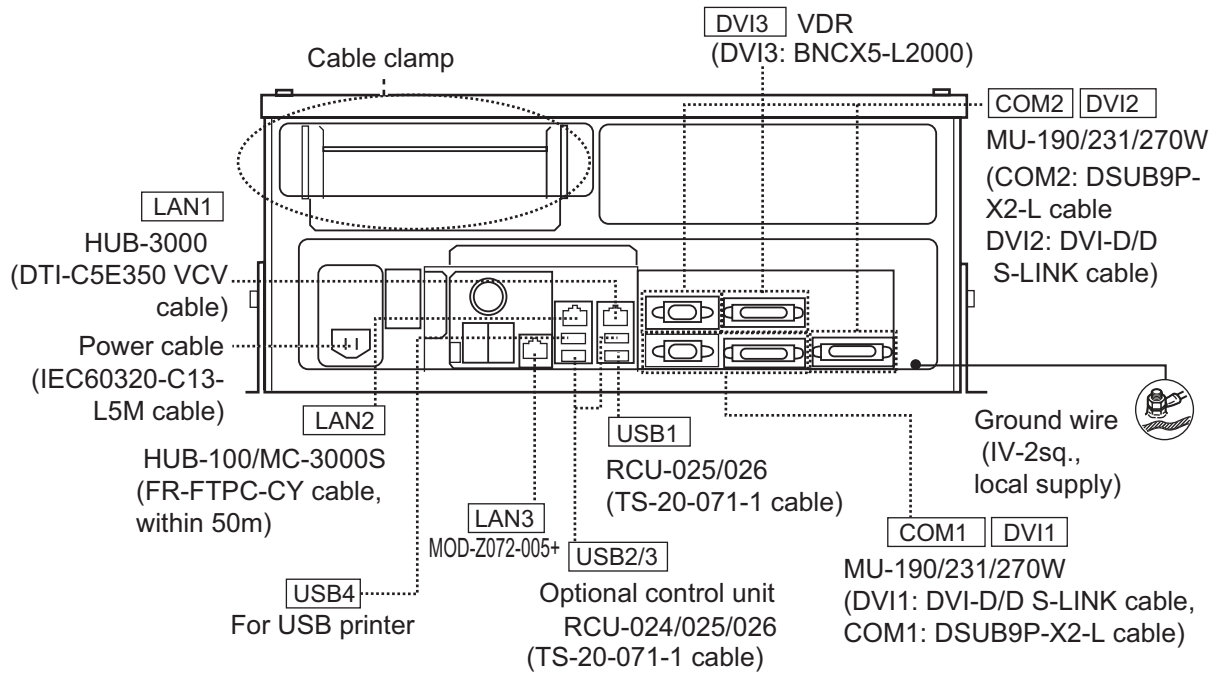

### **Cables connected at the wiring plate 1**

- USB cables from the control units
- Printer cable
- LAN cable (type: DTI-C5E350 VCV) from the HUB-3000
- LAN cable (type: FR-FTPC-CY) from the HUB-100/MC-3000S

### **Cables connected at the wiring plate 2**

- Power cable (Type: IEC60320-C13-L5M)
- LAN cable to the LAN3 port

2. WIRING

**How to fabricate the LAN cable**

Fabricate the LAN cable (FR-FTPC-CY, DTI-C5E350 VCV), as shown below. (Wrap both edges of the armor with vinyl tape.) Make sure the shield of the cable contacts the shell of the modular plug.

**Note:** For a locally supplied LAN cable, expose the armor and clamp the armor with the cable clamp.

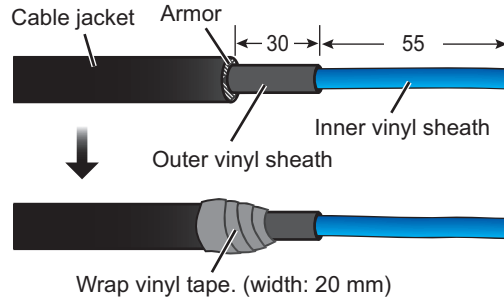

Expose inner vinyl sheath.

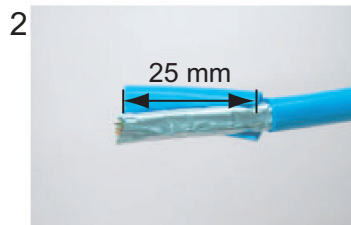

Remove the outer sheath by approx 25 mm. Be careful not to damage inner shield and cores.

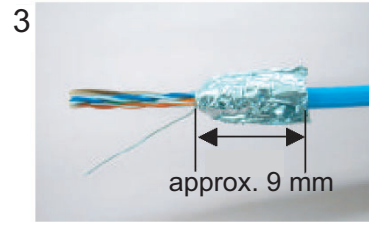

Fold back the shield, wrap it onto the outer sheath and cut it, leaving 9 mm.

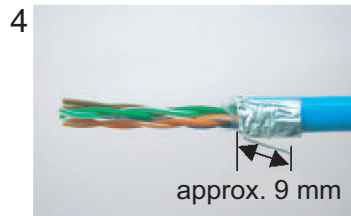

Fold back drain wire and cut it, leaving 9 mm.

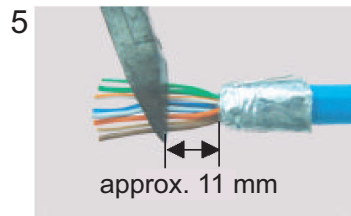

Straighten and flatten the core in order and cut them, leaving 11 mm.



Insert the cable into the modular plug so that the folded part of the shield enters into the plug housing. The drain wire should be located on the tab side of the jack.



Using special crimping tool MPT5-8AS (PANDUIT CORP.), crimp the modular plug. Finally check the plug visually.

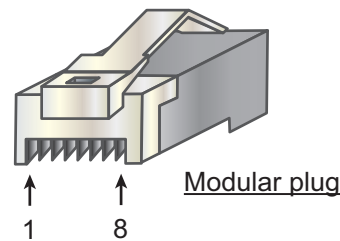

[Crossover cable]

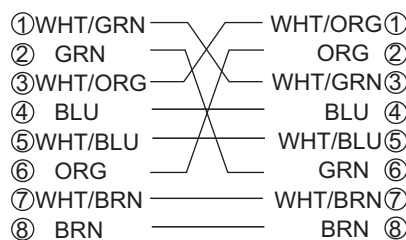

[Straight cable]

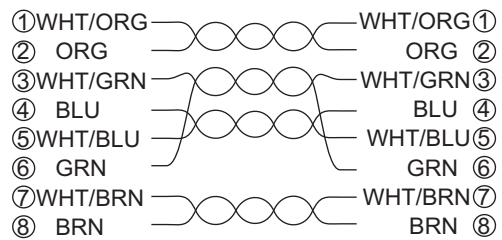

## 2.3.2 How to connect cables inside the processor unit

### How to fabricate the cables

Fabricate the JIS cables (see the Appendix for equivalent cables if not available locally) as shown below. Connect the cables to the WAGO connectors on the I/O Board (24P0124) inside the processor unit.

For locations of cables and cores, see the sticker on the reverse side of the top cover. (All dimensions in millimeters)

#### Fabrication of TTYCS series

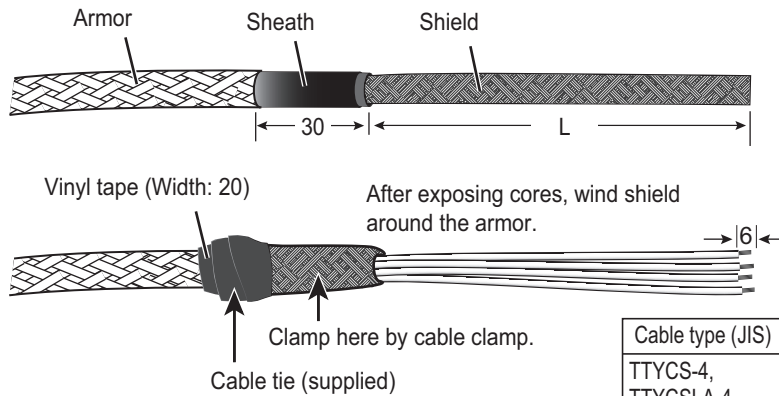

Cable type (JIS)	Length of "L"
TTYCS-4, TTYCSLA-4, TTYCS-1Q, TTYCSLA-1Q	400
TTYCS-10, TTYCSLA-10	380

#### Fabrication of TTYCSLA series

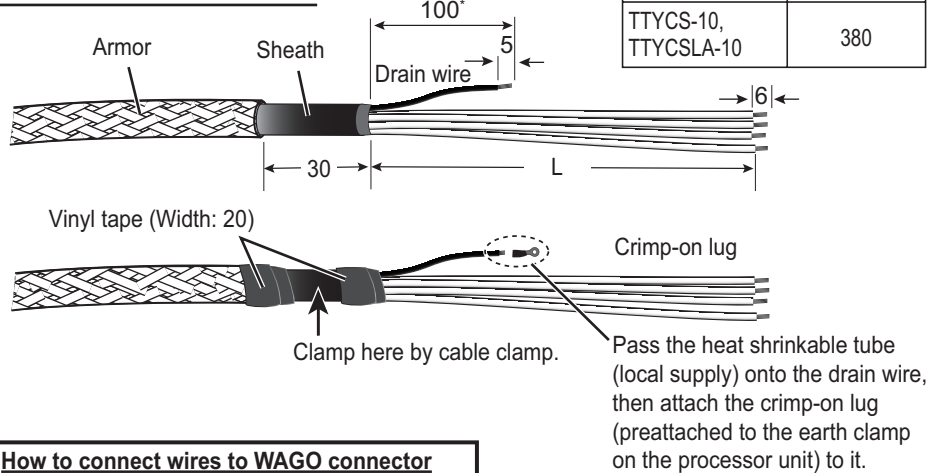

#### How to connect wires to WAGO connector

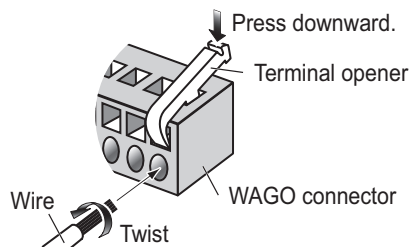

##### <Procedure>

1. Twist the cores.
2. Press the terminal opener downward.
3. Insert the wire to hole.
4. Remove the terminal opener.
5. Pull the wire to confirm that it is secure.

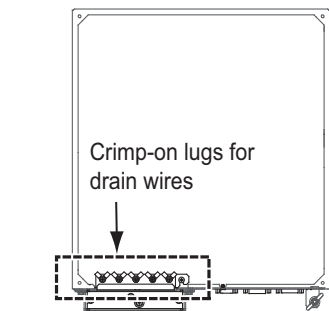

Processor unit, cover removed

**How to connect the cables**

1. Unfasten four screws (M4×8) to remove the top cover from the processor unit.
2. Unfasten the three bolts circled below to remove the upper plate of the cable clamp.

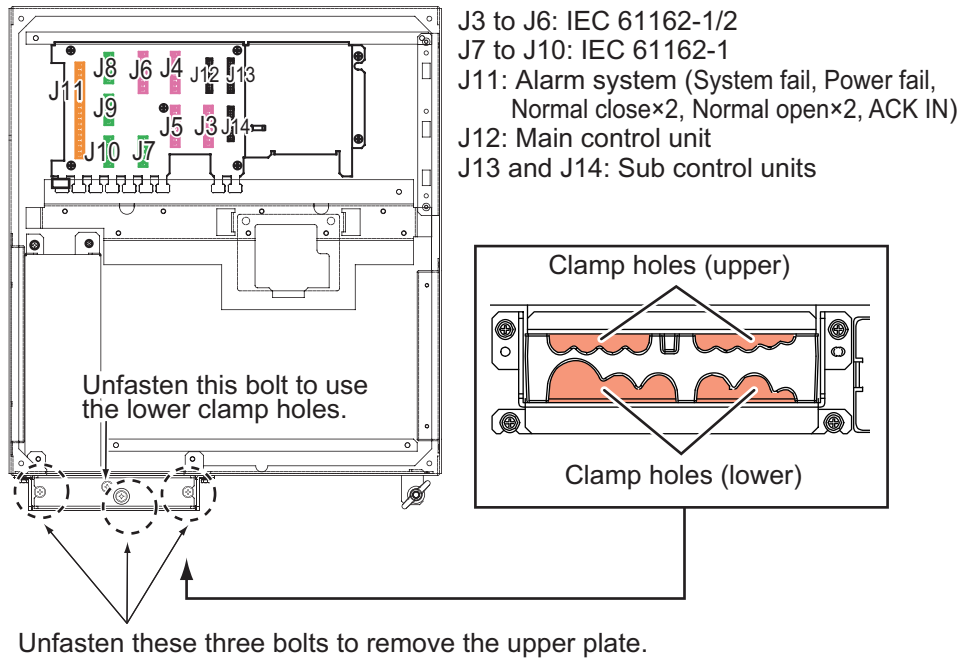

*Processor unit, top view*

3. Pass the cables through the clamp holes, then fasten the bolts removed at step 2 to fix the cables.

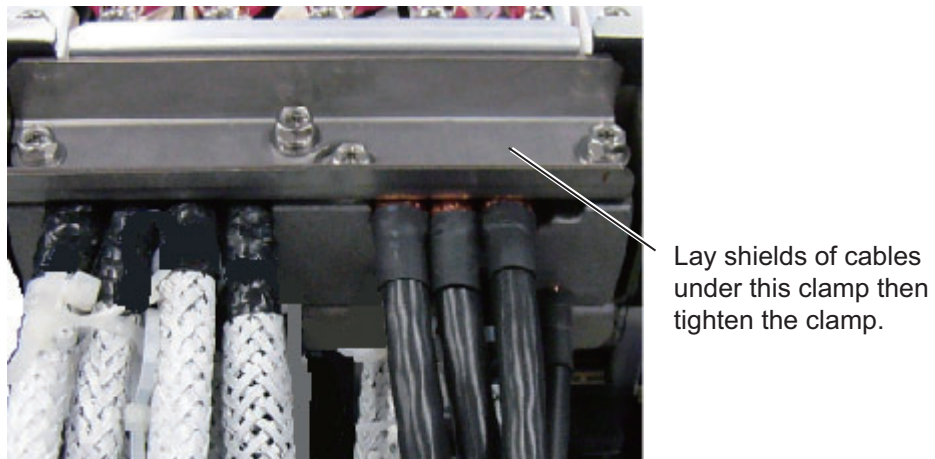

4. Connect the WAGO connectors to the I/O Board, referring to the interconnection diagram.

5. Bind the cables to the fixing metal in the processor unit with the cable ties (supplied).

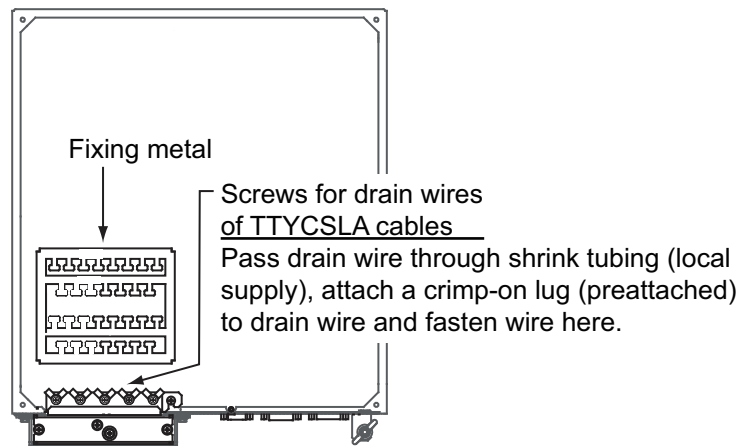

6. For the drain wire of the TTYCSLA series cable, attach shrink tubing (local supply) to drain wire, fasten a crimp-on lug (pre-attached at location shown below) to drain wire then fasten the wire with a screw.

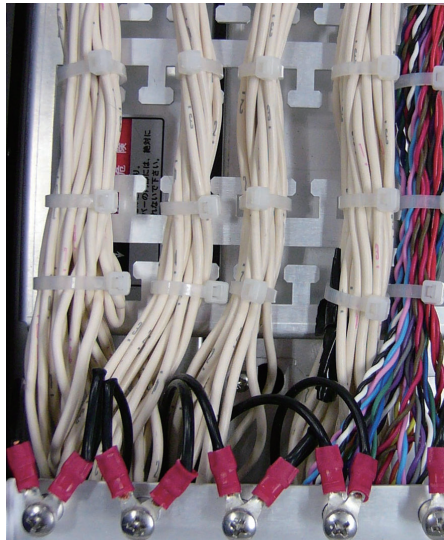

*Example of wiring inside the processor unit*

### 2.3.3 How to select the serial input/output format

#### How to set the termination resistors

Use the jumper blocks JP1 to JP4 on the I/O Board (24P0124) to set the termination resistors for J3 to J6 ON or OFF. The default setting is ON.

- When setting the starting/ending terminal for the multipoint connection, or multipoint is not connected (CH1 to CH4): termination resistor ON
- When not setting the starting/ending terminal for the multipoint connection (CH1 to CH4): termination resistor OFF

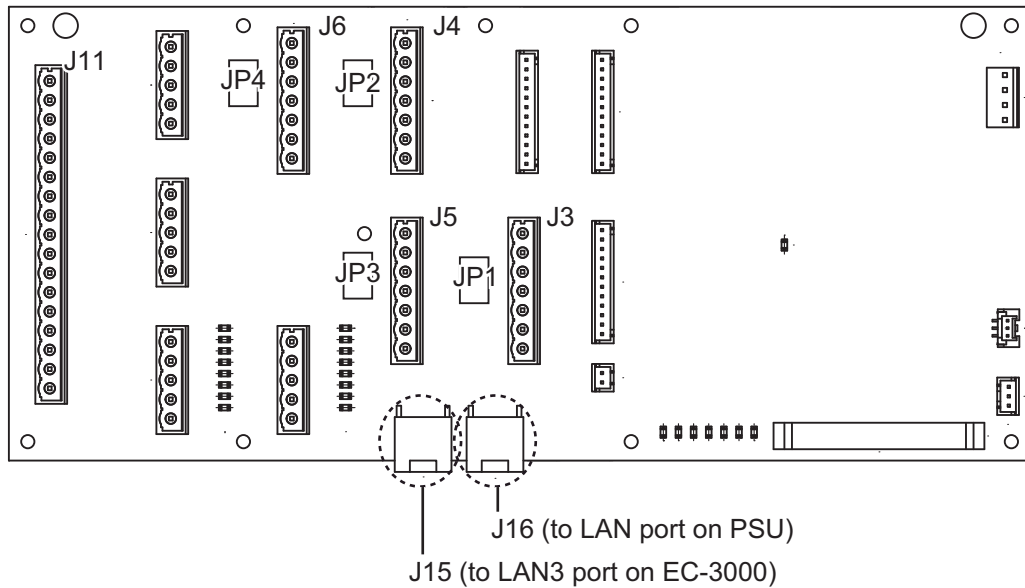

*Processor unit, I/O Board (24P0124)*

Jumper block JP1		Connector J3
1-2	SHORT	Termination resistor: ON (default setting)
2-3	OPEN	
1-2	OPEN	Termination connector: OFF
2-3	SHORT	

Jumper block JP2		Connector J4
1-2	SHORT	Termination resistor: ON (default setting)
2-3	OPEN	
1-2	OPEN	Termination connector: OFF
2-3	SHORT	

Jumper block JP3		Connector J5
1-2	SHORT	Termination resistor: ON (default setting)
2-3	OPEN	
1-2	OPEN	Termination connector: OFF
2-3	SHORT	

Jumper block JP4		Connector J6
1-2	SHORT	Termination resistor: ON (default setting)
2-3	OPEN	
1-2	OPEN	Termination connector: OFF
2-3	SHORT	



**How to select the serial input/output format**

Use the connectors J3 to J6 to set the input/output format for serial CH1 to CH4, from IEC 61162-1 or IEC 61162-2. For connectors J7 to J10, use TTYCS-1Q or TTYCSLA-1Q cable for a connector.

**Connector J3**

Pin #	Signal	In/Out	Description	IEC 61162-2	IEC 61162-1
1	TD1-A	Out	Serial CH1, output IEC 61162-1/2	TTYCS(LA)-4	TTYCS(LA)-4
2	TD1-B	Out	Serial CH1, output IEC 61162-1/2		
3	RD1-A	In	Serial CH1, input IEC 61162-2		No connection
4	RD1-B	In	Serial CH1, input IEC 61162-2		
5	ISOGND1	-	Isolation GND (CH1)		
6	RD1-H	In	Serial CH1, input IEC 61162-1	No connection	TTYCS(LA)-4
7	RD1-C	In	Serial CH1, input IEC 61162-1		

**Connector J4**

Pin #	Signal	In/Out	Description	IEC 61162-2	IEC 61162-1
1	TD2-A	Out	Serial CH2, output IEC 61162-1/2	TTYCS(LA)-4	TTYCS(LA)-4
2	TD2-B	Out	Serial CH2, output IEC 61162-1/2		
3	RD2-A	In	Serial CH2, input IEC 61162-2		No connection
4	RD2-B	In	Serial CH2, input IEC 61162-2		
5	ISOGND2	-	Isolation GND (CH2)		
6	RD2-H	In	Serial CH2, input IEC 61162-1	No connection	TTYCS(LA)-4
7	RD2-C	In	Serial CH2, input IEC 61162-1		

**Connector J5**

Pin #	Signal	In/Out	Description	IEC 61162-2	IEC 61162-1
1	TD3-A	Out	Serial CH3, output IEC 61162-1/2	TTYCS(LA)-4	TTYCS(LA)-4
2	TD3-B	Out	Serial CH3, output IEC 61162-1/2		
3	RD3-A	In	Serial CH3, input IEC 61162-2		No connection
4	RD3-B	In	Serial CH3, input IEC 61162-2		
5	ISOGND3	-	Isolation GND (CH3)		
6	RD3-H	In	Serial CH3, input IEC 61162-1	No connection	TTYCS(LA)-4
7	RD3-C	In	Serial CH3, input IEC 61162-1		

**Connector J6**

Pin #	Signal	In/Out	Description	IEC 61162-2	IEC 61162-1
1	TD4-A	Out	Serial CH4, output IEC 61162-1/2	TTYCS(LA)-4	TTYCS(LA)-4
2	TD4-B	Out	Serial CH4, output IEC 61162-1/2		
3	RD4-A	In	Serial CH4, input IEC 61162-2		No connection
4	RD4-B	In	Serial CH4, input IEC 61162-2		
5	ISOGND4	-	Isolation GND (CH4)		
6	RD4-H	In	Serial CH4, input IEC 61162-1	No connection	TTYCS(LA)-4
7	RD4-C	In	Serial CH4, input IEC 61162-1		

2. WIRING

Connector J7

Pin#	Signal	In/Out	Description	Remarks
1	TD5-A	Out	Serial CH5, output IEC 61162-1	Use TTYCS(LA)-1Q, IEC 61162-1 only
2	TD5-B	Out	Serial CH5, output IEC 61162-1	
3	RD5-H	In	Serial CH5, input IEC 61162-1	
4	RD5-C	In	Serial CH5, input IEC 61162-1	
5	GND	-	GND	

Connector J8

Pin#	Signal	In/Out	Description	Remarks
1	TD6-A	Out	Serial CH6, output IEC 61162-1	Use TTYCS(LA)-1Q, IEC 61162-1 only
2	TD6-B	Out	Serial CH6, output IEC 61162-1	
3	RD6-H	In	Serial CH6, input IEC 61162-1	
4	RD6-C	In	Serial CH6, input IEC 61162-1	
5	GND	-	GND	

Connector J9

Pin#	Signal	In/Out	Description	Remarks
1	TD7-A	Out	Serial CH7, output IEC 61162-1	Use TTYCS(LA)-1Q, IEC 61162-1 only
2	TD7-B	Out	Serial CH7, output IEC 61162-1	
3	RD7-H	In	Serial CH7, input IEC 61162-1	
4	RD7-C	In	Serial CH7, input IEC 61162-1	
5	GND	-	GND	

Connector J10

Pin#	Signal	In/Out	Description	Remarks
1	TD8-A	Out	Serial CH8, output IEC 61162-1	Use TTYCS(LA)-1Q, IEC 61162-1 only For PSU
2	TD8-B	Out	Serial CH8, output IEC 61162-1	
3	RD8-H	In	Serial CH8, input IEC 61162-1	
4	RD8-C	In	Serial CH8, input IEC 61162-1	
5	GND	-	GND	

**How to set contact input/output**

The connector J11 can be used for the connection of contact input or voltage input. Refer to the figures shown below to make the wiring which complies with the input specification.

**Note:** The input must not exceed the range of the input voltage, to prevent malfunction.

-Setting for voltage input: 21.6V to 31.2V

-Setting for contact input: Voltage cannot be input (contact signal only).

- (Setting for contact input)

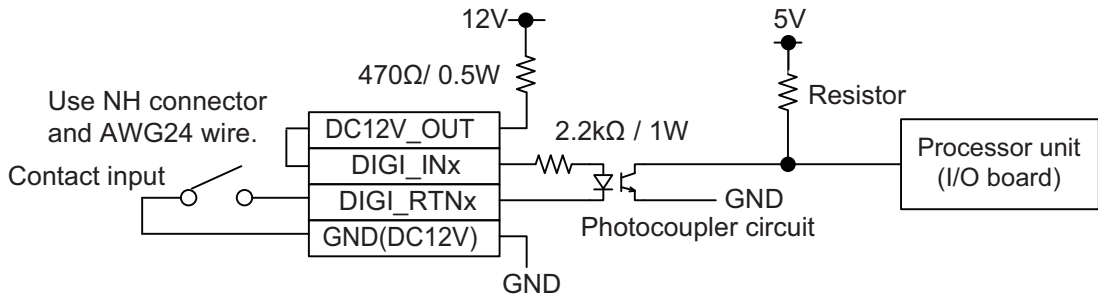

- (Setting for voltage input)

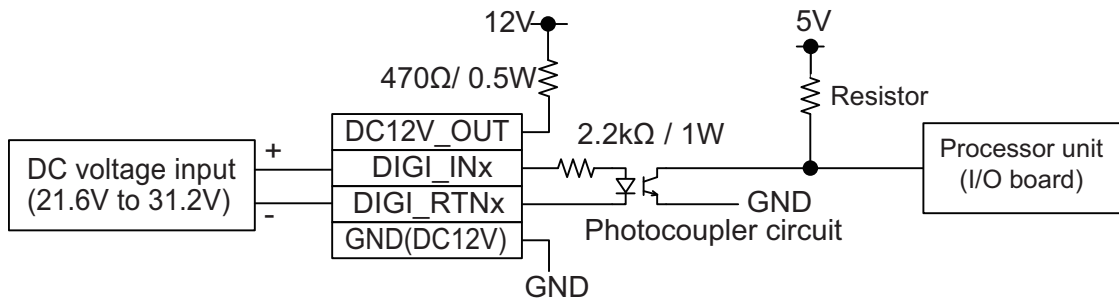

Connector J11

Pin #	Signal name	In/Out	Description	Contact input	Voltage input
1	SYS_FAIL-A	Out	System fail output	TTYCS(LA)-10	TTYCS(LA)-10
2	SYS_FAIL-B	Out	System fail output		
3	PWR_FAIL-A	Out	Power fail output		
4	PWR_FAIL-B	Out	Power fail output		
5	NC1-A	Out	Alarm output (NC1)		
6	NC1-B	Out	Alarm output (NC1)		
7	NC2-A	Out	Alarm output (NC2)		
8	NC2-B	Out	Alarm output (NC2)		
9	NO1-A	Out	Alarm output (NO1)		
10	NO1-B	Out	Alarm output (NO1)		
11	NO2-A	Out	Alarm output (NO2)		
12	NO2-B	Out	Alarm output (NO2)		
13	DC12V_OUT	Out	ACK input	#13-#14: short	No connection
14	DIGI_IN1	In	ACK input		TTYCS(LA)-10
15	DIGI_RTN1	Out	ACK input	TTYCS(LA)-10	
16	GND (DC12V)	In	ACK input		No connection
17	GND	-	GND	NO connection	

**Note:** NC1/2 and NO1/2 are output with a fixed value.

## 2.4 Power Supply Unit

This procedure shows how to wire the power supply. For details see the interconnection diagram.

1. Connect the ground wire between the ground terminal on the chassis and the ship's earth.

**Note:** Electrical shock can result if the ground wire is not connected properly.

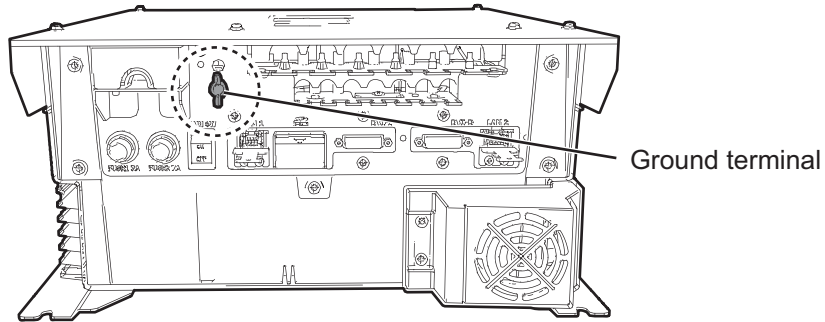

2. Unfasten five screws to open the cover of the power supply unit.

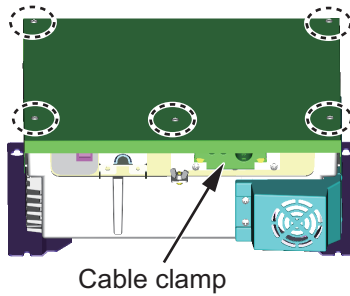

3. Unfasten two screws from the cable clamp to separate the cable clamp assembly.

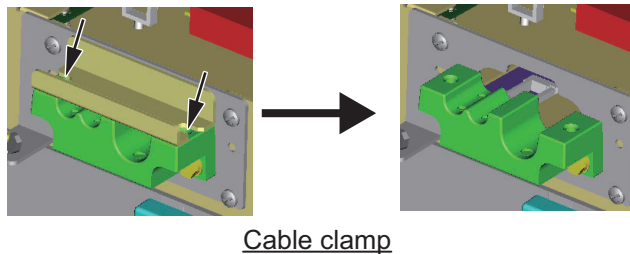

4. Pass the LAN and serial cables through the cable clamp.

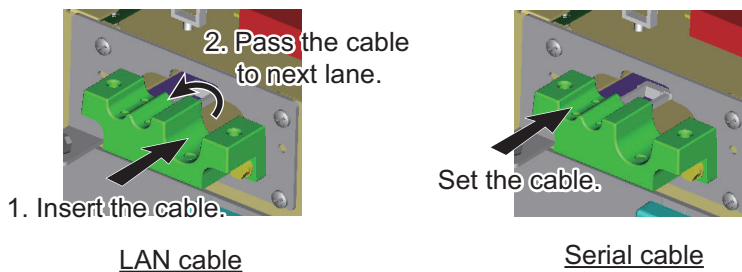

5. As shown below, fabricate the cables. For retrofit, the optional LAN Signal Converter kit. See section 2.7 for wiring.  
TTYCS(LA)-1Q

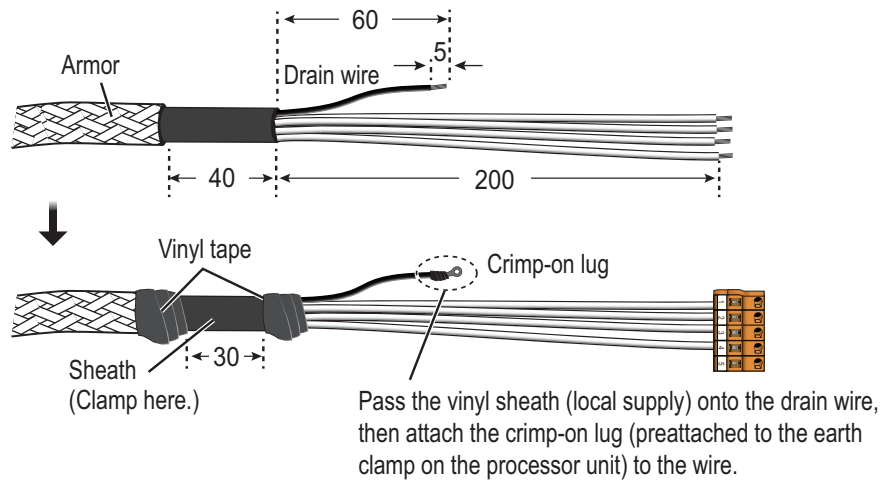

LAN cable

See "How to fabricate the LAN cable" on page 2-16 for how to attach the LAN cable connector.

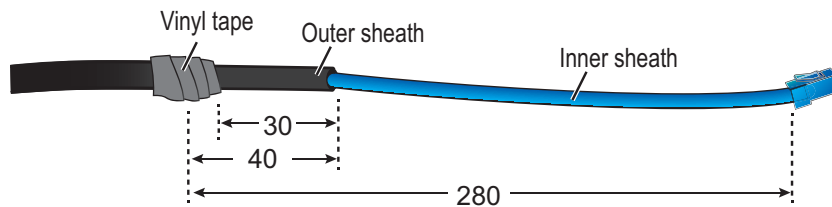

6. Connect the cables fabricated at step 4 as shown below.

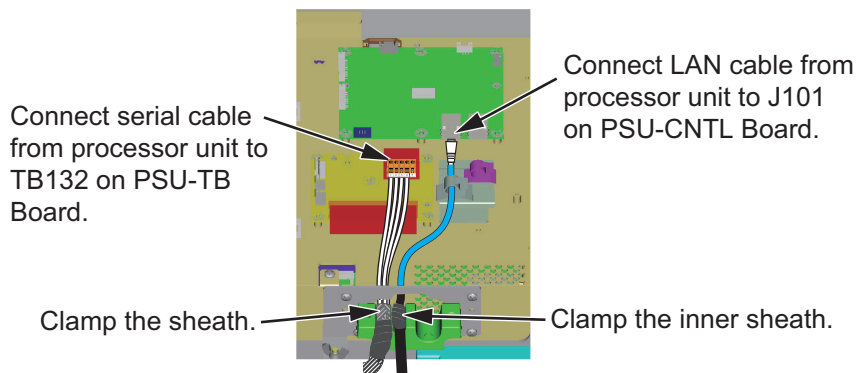

7. Fabricate the antenna cable as shown below.

RW-00135

See "How to fabricate the LAN cable" on page 2-16 for how to attach the LAN cable connector.

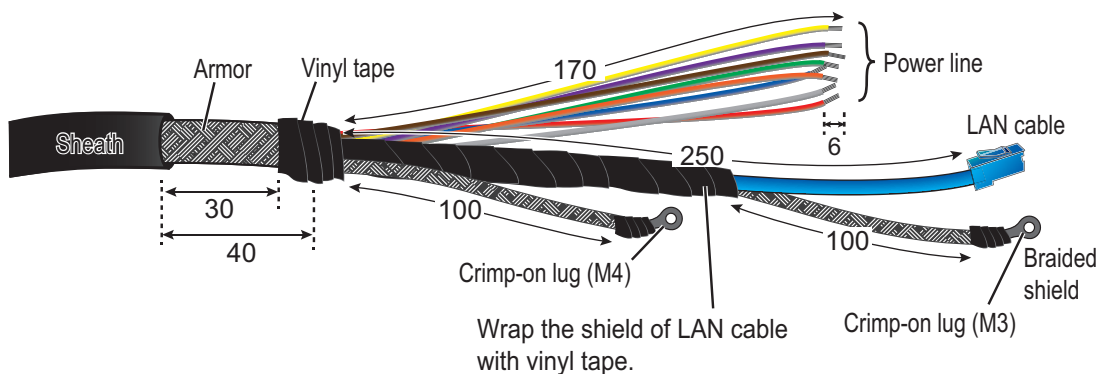

RW-9600

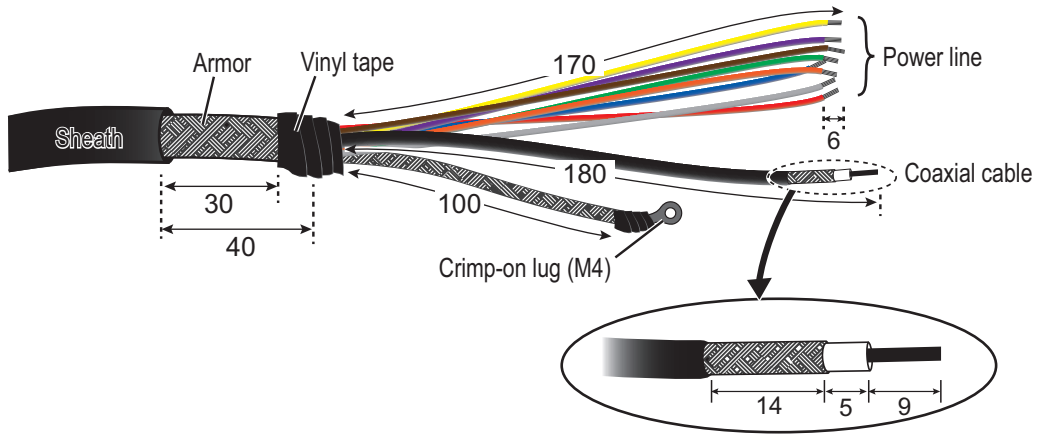

8. Pass the antenna cable through the cable clamp.

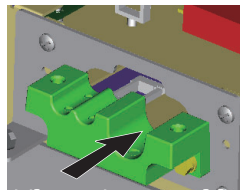

Insert the antenna cable.

9. Connect the power line of the antenna cable to the 13-pin WAGO connector.

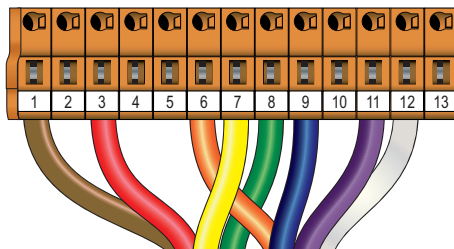

Pin	Color	Pin	Color
1	Brown	8	Green
3	Red	9	Blue
6	Orange	11	Purple
7	Yellow	12	White

10. Connect the power line and the LAN cable of the antenna cable as shown below.

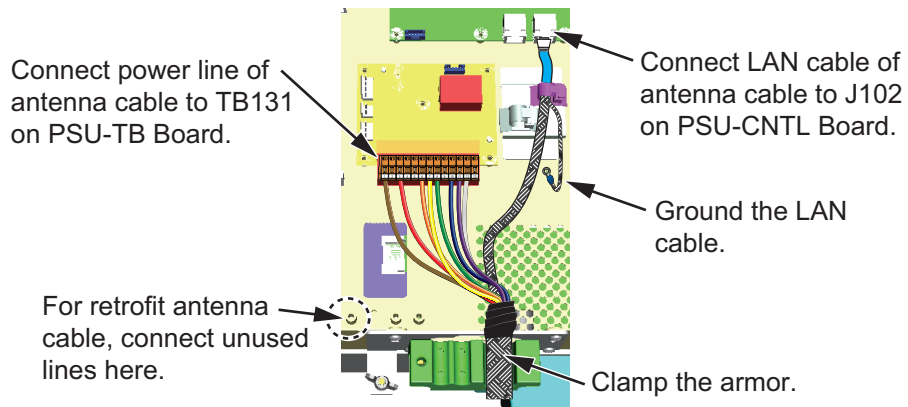

- Connect the shield wires of the antenna cable and serial cable for the processor unit.

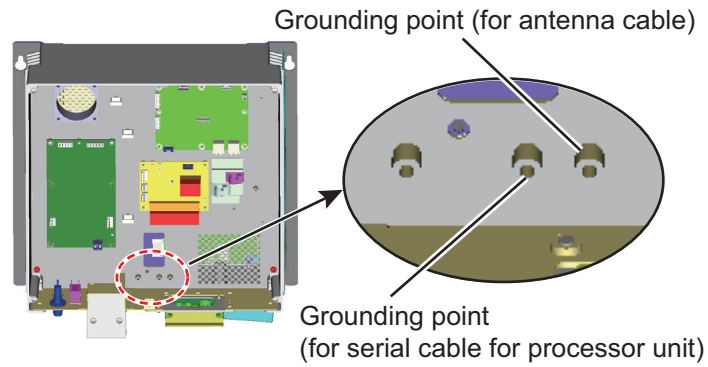

- Reattach the cable clamp assembly.
- Remove the connector cover for the power cable (2 places).

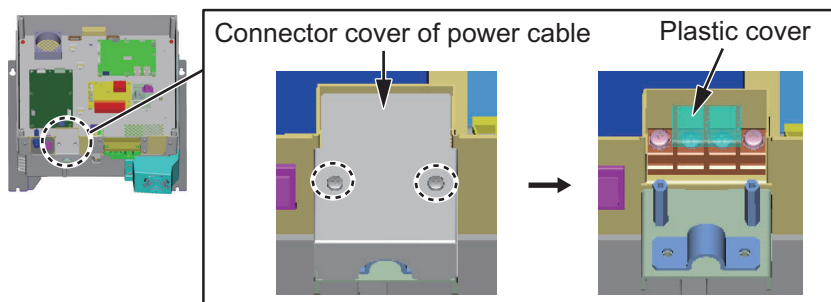

- Fabricate the power cable (DPYC-2.5) as shown below.

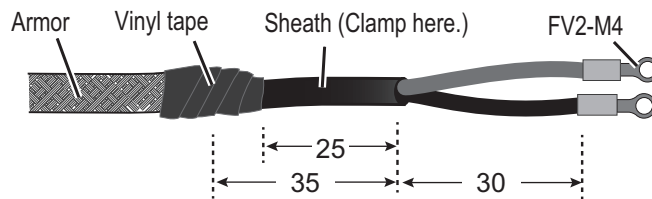

- Pull up the plastic cover and connect the power cable.

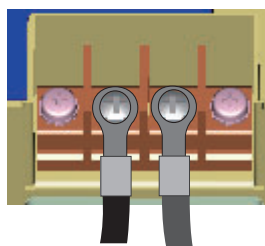

- Remount the connector cover for the power cable.
- Reattach the cover of the power supply unit.

## 2.5 Monitor Unit

For the wiring of the monitor unit, see the operator's manual supplied with the monitor unit. Also, for resolution and image data output settings, see the Instruction Manual (E32-01305-\*).

### Mounting considerations

- Standard type
  - Connect the radar main monitor to the DVI1 and COM1 ports.
  - Connect the sub radar monitor to the DVI2 and COM2 ports.
- VDR connection
 

To connect a VDR, it is necessary to output data in analog format. See the Instruction Manual (E32-01305-\*). To connect a VDR to the DVI3 port, use the optional DVI-BNCX5-L2000 cable to output the RGB signal from the DVI-I. See the operator's manual supplied with the VDR. Adjustment of the output is necessary.

### Menu Setting

The [INSTALLATION SETTING] menu appears only when the power is turned on for the first time after installation of the monitor unit.

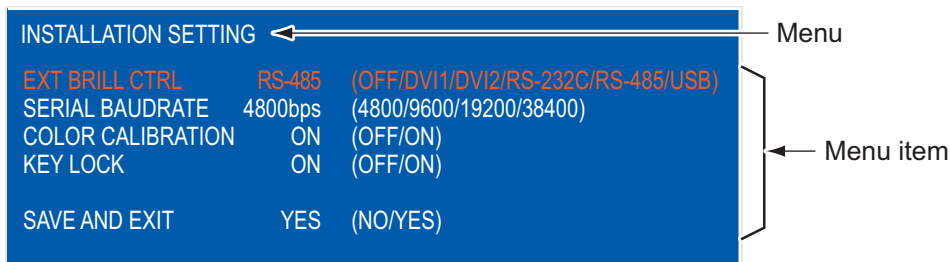

Adjust the settings referring to the following table.

EXT BRILL CTRL	SERIAL BAUD RATE	COLOR CALIBRATION	KEY LOCK	DVI PWR SYNC*
RS-485	4800bps	ON	ON	ON

\*: [DVI PWR SYNC] is the slide switch at the bottom rear of the monitor unit. Confirm that this switch is set to [ON] (default setting). See Slide switch below for details.

### Slide switch

Set the slide switch to "ON" (default setting). This setting automatically powers the monitor unit on or off according to the DVI signal input. The power switch of the monitor unit is inoperative.

**Note:** The OFF position provides control of the monitor unit power with the power switch of the monitor unit.

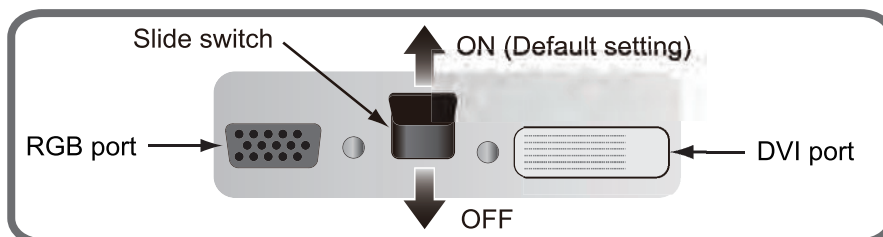



### How to open the [INSTALLATION SETTING] menu

Turn off the monitor unit. While you hold the **DISP** key, press the **BRILL** key to turn on the monitor unit. Keep the **DISP** key pressed until the [INSTALLATION SETTING] menu appears.

**Note:** When the [DVI PWR SYNC] slide switch is ON, turn on the connected external equipment while you press the **DISP** key to turn on the monitor unit.

## 2.6 Sensor Adapters (option)

A maximum of eight MC-3000S can be connected to a sensor network (for the redundant connection: 16). The MC-3000S (serial input/output, IEC61162-2/1, 4ch) can connect a maximum of 10 sensor adapters, using the MC1.5-W cables. The maximum number of MC-3010A units is five.

When fabricating the MC1.5-W cables, use the lot terminal (ferrule type, supplied) to maintain performance. Use the ferrule-type terminals (supplied) to connect the cables to the terminals in the sensor adapters. This connection requires a crimping tool (CRIMPFOX10S, option). For the relations between the connectors and rod terminals, see page AP-2. Also, the stickers attached on the reverse side of the covers show the detailed connections.

#### How to attach ferrule-type terminal

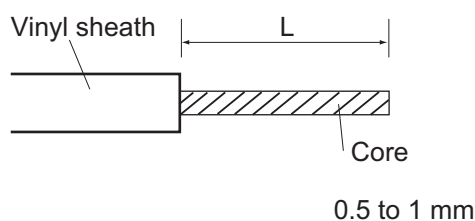

Ferrule-type terminal	Length of "L"
AI 1.5-6 BK (BLK)	6 mm
AI 0.34-6 TQ (BLU)	
AI 0.75-6 GY (GREY)	
AI 1-6 RD (RED)	
AI 0.14-8 GY(GREY)	8 mm

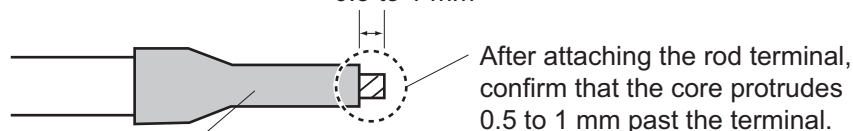

Ferrule-type rod terminal:

After attaching the rod terminal, use the optional crimping tool CRIMPFOX 10S to crimp.

Attach the cables to the applicable pins.

Pin no.	Cable color	Signal
1	Red	24V_OUT or 24V_IN
2	Black	24V_GND
3	White	MODBUS-A
4	Blue	MODBUS-B
5	Gray	GND

**Note 1:** Use the MC1.5-W cable between the sensor adapters.

**Note 2:** The total length of the MC1.5-W cables must be less than 6 m to prevent malfunction.

## 2. WIRING

### 2.6.1 MC-3000S

Use the LAN cable FR-FTPC-CY cable to connect the MC-3000S and the processor unit. With HUB-100, a maximum of eight MC-3000S can be connected.

#### Fabrications

LAN cable (FR-FTPC-CY)

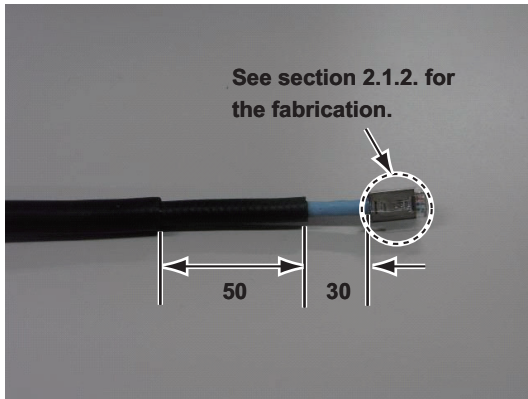

TTYCS-1Q cable

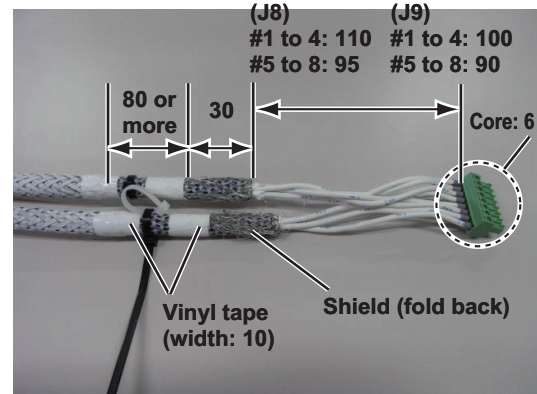

MC1.5-W-L600/1000/2000/3000 cable

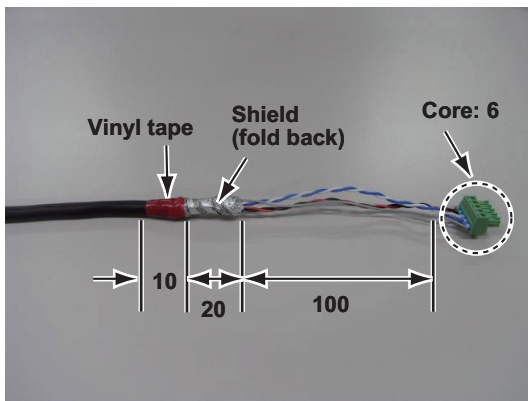

TTYCSLA-1Q cable

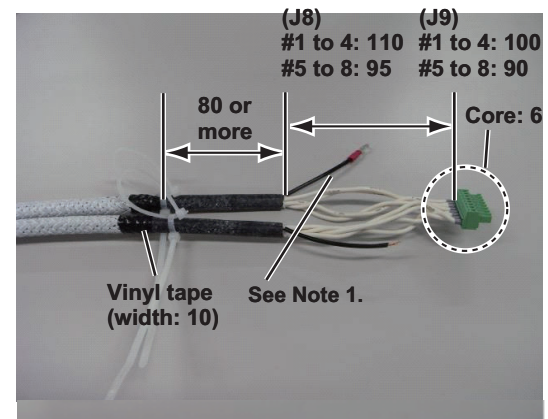

TTYCS-1 cable

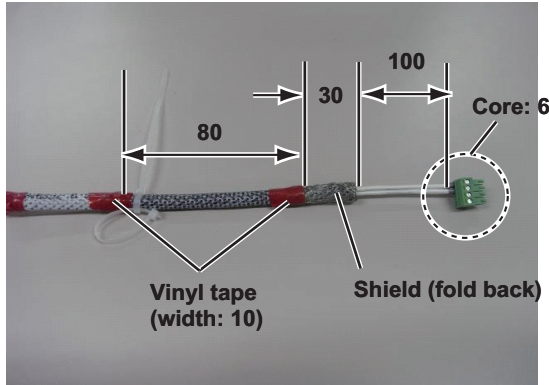

TTYCSLA-1 cable

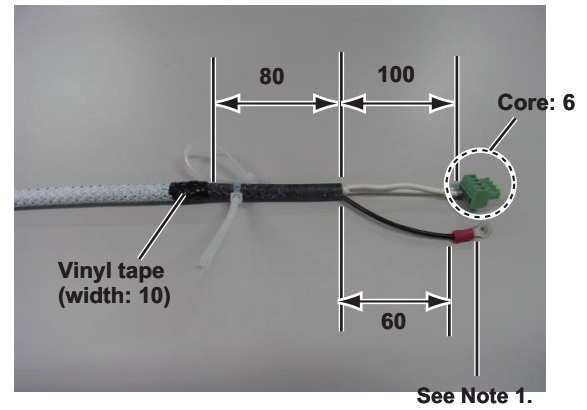

TTYCS-4 cable

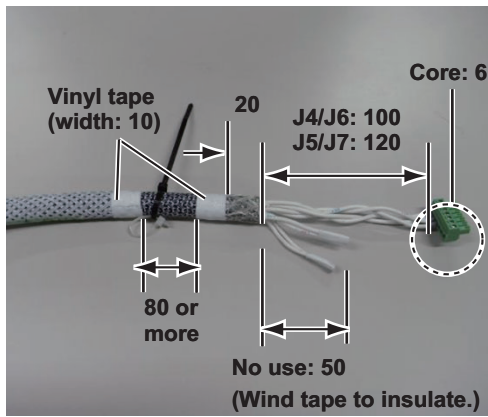

TTYCSLA-4 cable

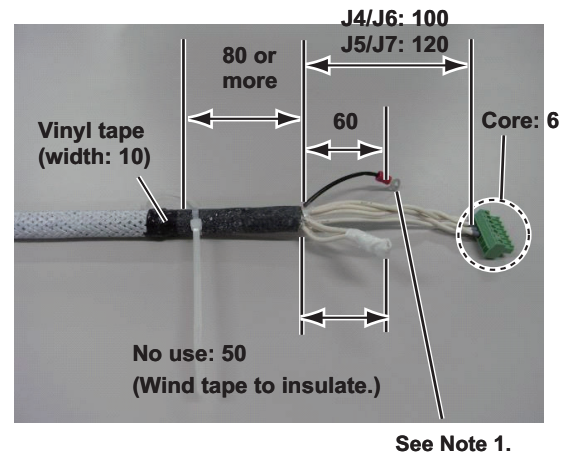

DPYC-1.5 cable

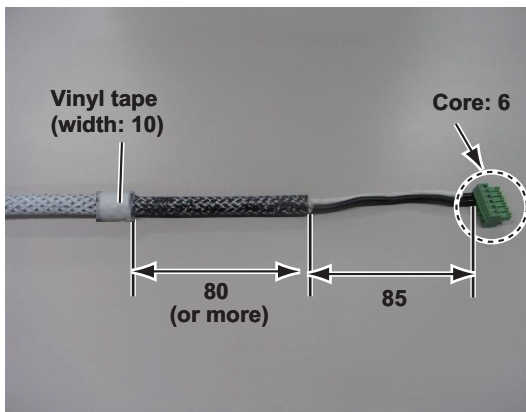

**Note 1:** Pass drain wire through shrink tubing (local supply), then attach crimp-on lug (pre-attached in unit).

**Note 2:** See "How to fabricate the LAN cable" on page 2-16 for how to fabricate the LAN cable.

**Connections**

Unfasten four screws to remove the cover. Pass the cables through the clamps and attach the cables to respective connectors. The shield (or drain wire) must lie in (connected to) the clamp.

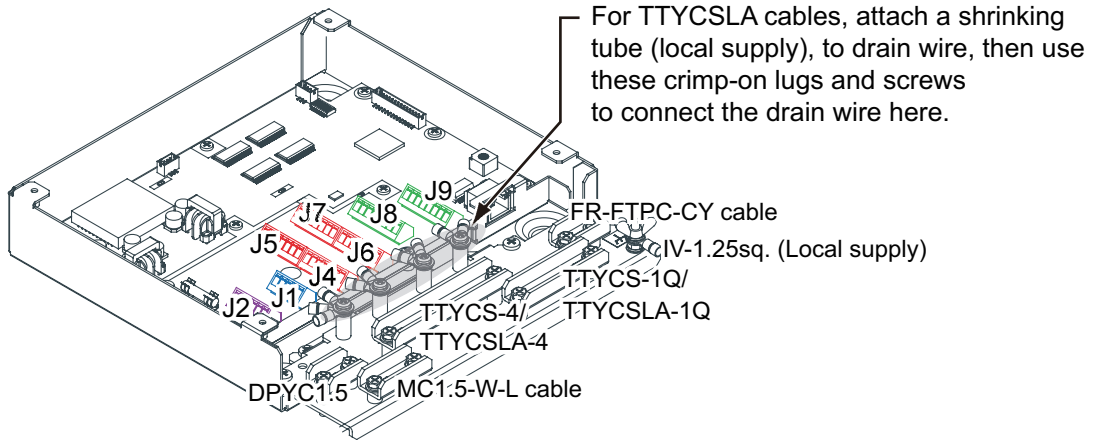

**Note:** Be sure each cable shield lies in the cable clamp.

**How to set NC/NO output (J2)**

The POWER FAIL signal on the connector J2 can be set to NC (normal close) output or NO (normal open) output as shown in the table below.

Connector J2

Pin #	Signal name	In/Out	Remarks	NO	NC
1	24V_IN	-	24 VDC	DPYC-1.5	
2	24V_GND	-	GND (24 VDC)		
3	PWR_FAIL_A	Out	Power fail output	TTYCS(LA)-1	No connection
4	PWR_FAIL_COM	Out	Power fail output		TTYCS(LA)-1
5	PWR_FAIL_B	Out	Power fail output	No connection	

**How to set input specification (J4 to J9)**

For connectors J4 to J7, the connections are different depending on the input specifications as shown below.

Connector J4

Pin #	Signal name	In/Out	Remarks	IEC 61162-2	IEC 61162-1
1	TD1-A	Out	Serial CH1, output IEC 61162-1/2/modbus	TTYCS(LA)-4	TTYCS(LA)-4
2	TD1-B	Out	Serial CH1, output IEC 61162-1/2/modbus		
3	RD1-A	In	Serial CH1, output IEC 61162-2/modbus		
4	RD1-B	In	Serial CH1, output IEC 61162-2/modbus		
5	ISOGND1	-	Isolation, GND (CH1)		
6	RD1-H	In	Serial CH1, output IEC 61162-1	No connection	TTYCS(LA)-4
7	RD1-C	In	Serial CH1, output IEC 61162-1		

Connector J5

Pin #	Signal name	In/ Out	Remarks	IEC 61162-2	IEC 61162-1	
1	TD2-A	Out	Serial CH2, output IEC 61162-1/2/modbus	TTYCS(LA)-4	TTYCS(LA)-4	
2	TD2-B	Out	Serial CH2, output IEC 61162-1/2/modbus			
3	RD2-A	In	Serial CH2, output IEC 61162-2/modbus			No connection
4	RD2-B	In	Serial CH2, output IEC 61162-2/modbus			
5	ISOGND2	-	Isolation, GND (CH2)			
6	RD2-H	In	Serial CH2, output IEC 61162-1	No connection	TTYCS(LA)-4	
7	RD2-C	In	Serial CH2, output IEC 61162-1			

Connector J6

Pin #	Signal name	In/ Out	Remarks	IEC 61162-2	IEC 61162-1	
1	TD3-A	Out	Serial CH3, output IEC 61162-1/2	TTYCS(LA)-4	TTYCS(LA)-4	
2	TD3-B	Out	Serial CH3, output IEC 61162-1/2			
3	RD3-A	In	Serial CH3, output IEC 61162-2			No connection
4	RD3-B	In	Serial CH3, output IEC 61162-2			
5	ISOGND3	-	Isolation, GND (CH3)			
6	RD3-H	In	Serial CH3, output IEC 61162-1	No connection	TTYCS(LA)-4	
7	RD3-C	In	Serial CH3, output IEC 61162-1			

Connector J7

Pin #	Signal name	In/ Out	Remarks	IEC 61162-2	IEC 61162-1	
1	TD4-A	Out	Serial CH4, output IEC 61162-1/2	TTYCS(LA)-4	TTYCS(LA)-4	
2	TD4-B	Out	Serial CH4, output IEC 61162-1/2			
3	RD4-A	In	Serial CH4, output IEC 61162-2			No connection
4	RD4-B	In	Serial CH4, output IEC 61162-2			
5	ISOGND4	-	Isolation, GND (CH4)			
6	RD4-H	In	Serial CH4, output IEC 61162-1	No connection	TTYCS(LA)-4	
7	RD4-C	In	Serial CH4, output IEC 61162-1			

Connector J8

Pin #	Signal name	In/ Out	Description	Used cable
1	TD5-A	Out	Serial CH5, output IEC 61162-1	TTYCS-1Q or TTYCSLA-1Q
2	TD5-B	Out	Serial CH5, output IEC 61162-1	
3	RD5-H	In	Serial CH5, input IEC 61162-1	
4	RD5-C	In	Serial CH5, input IEC 61162-1	
5	TD6-A	Out	Serial CH6, output IEC 61162-1	
6	TD6-B	Out	Serial CH6, output IEC 61162-1	
7	RD6-H	In	Serial CH6, input IEC 61162-1	
8	RD6-C	In	Serial CH6, input IEC 61162-1	

Connector J9

Pin#	Signal name	In/Out	Description	Used cable
1	TD7-A	Out	Serial CH7, output IEC 61162-1	TTYCS-1Q or TTYCSLA-1Q
2	TD7-B	Out	Serial CH7, output IEC 61162-1	
3	RD7-H	In	Serial CH7, input IEC 61162-1	
4	RD7-C	In	Serial CH7, input IEC 61162-1	
5	TD8-A	Out	Serial CH8, output IEC 61162-1	
6	TD8-B	Out	Serial CH8, output IEC 61162-1	
7	RD8-H	In	Serial CH8, input IEC 61162-1	
8	RD8-C	In	Serial CH8, input IEC 61162-1	

**Case gasket OP24-28**

The optional kit OP24-28 protects the connectors on the MC-3000S to waterproofing standard IPX2.

*Case gasket (type: OP24-28, code no.: 001-169-970)*

Name	Type	Code No.	Qty	Remarks
Case gasket (serial)	24-014-2051	100-367-880-10	2	For MC-3000S

1. Unfasten four binding screws to remove the cover from the adapter.

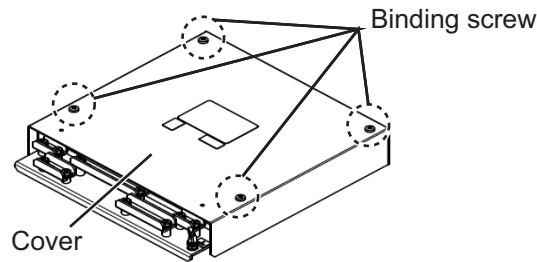

2. Peel the paper from the case gasket, then attach the case gasket to the reverse side of the cover and the body unit as shown below.

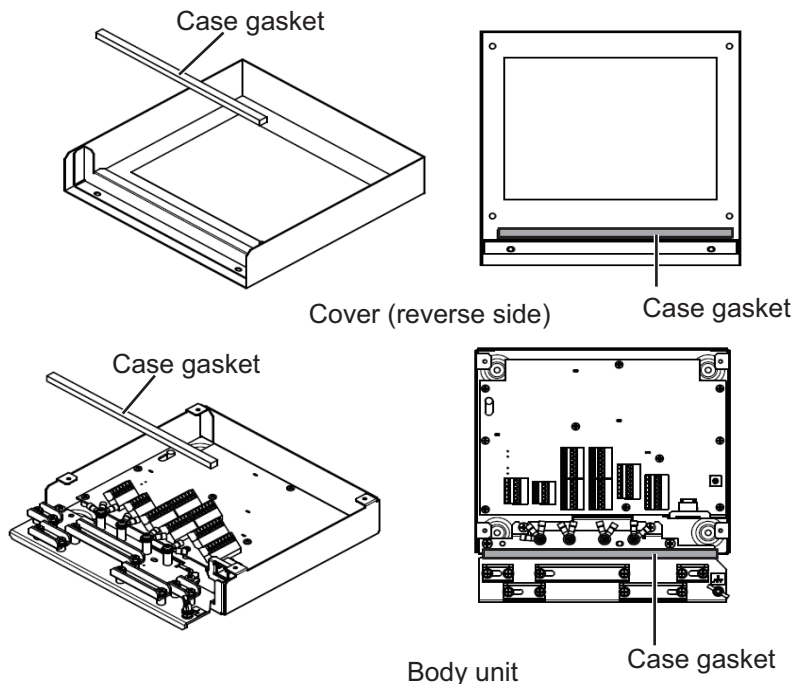

3. Attach the cover to the MC-3000S body unit.

## 2.6.2 MC-3010A/3020D/3030D

- MC-3010A: Inputs analog signal. To use MC-3010A as current input, connect short pins to each terminals.
- MC-3020D: Inputs digital signal (8ch contact input). Contact or voltage input is selectable (contact input requires short pins).
- MC-3030D: Outputs digital signal (8ch, normal open/close).

### Fabrications

MC1.5-W-L600/1000/2000/3000 cable  
(Input)

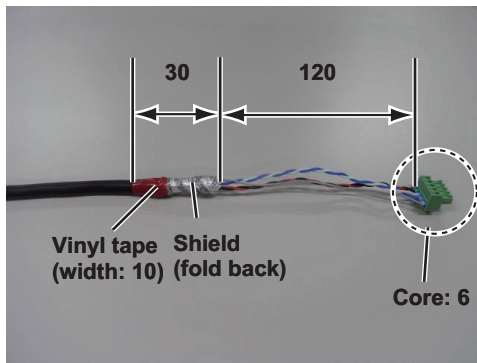

TTYCSLA-1 (MC-3010A)

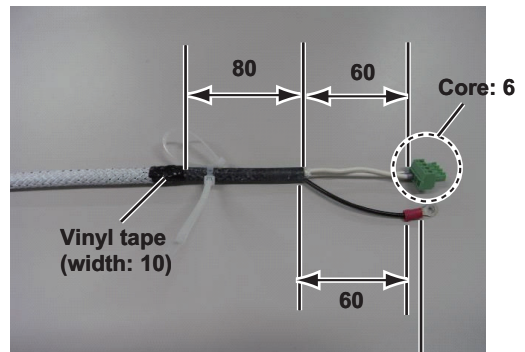

Pass drain wire through shrink tubing (local supply), then attach crimp-on lug (pre-attached in unit).

MC1.5-W-L600/1000/2000/3000 cable  
(Output)

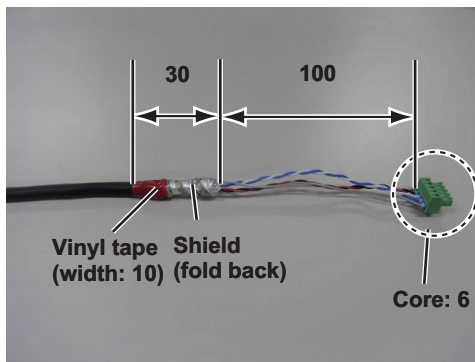

TTYCS-1 (MC-3010A)

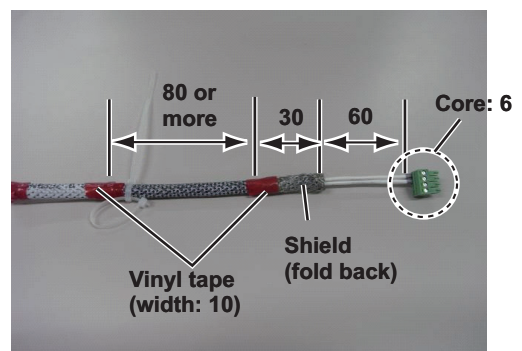

MPYC-12 cable (MC-3030D)

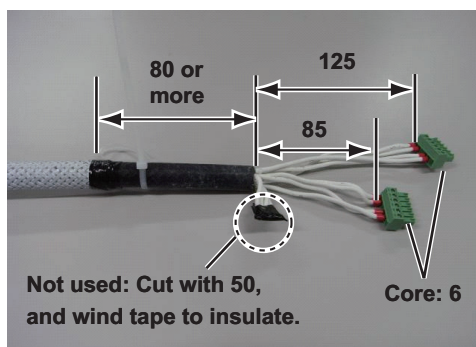

MPYC-12 cable (MC-3020D)

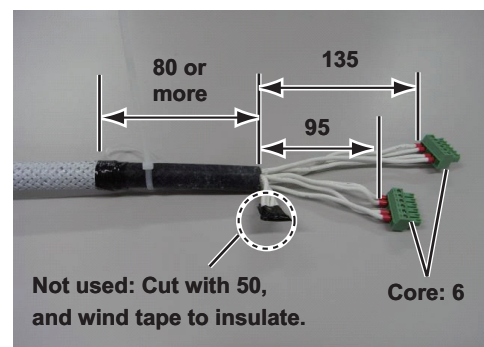

**Connection**

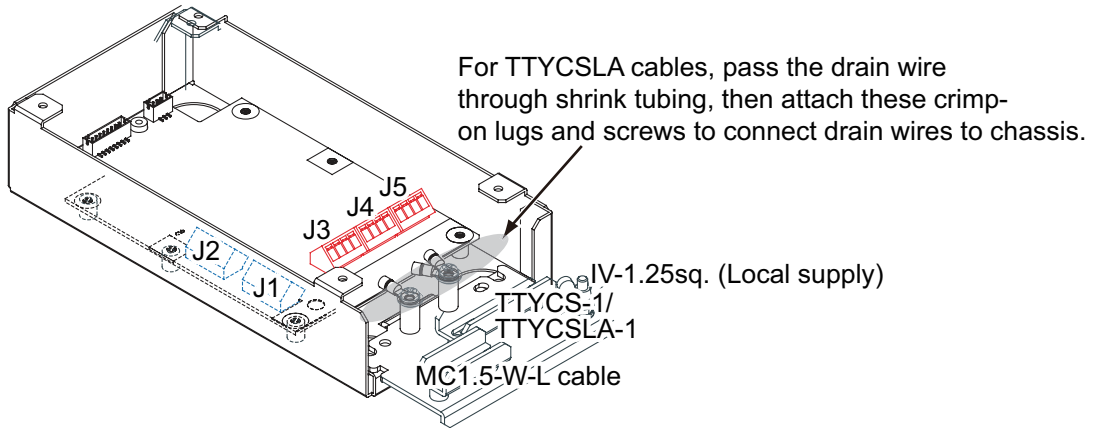

MC-3010A

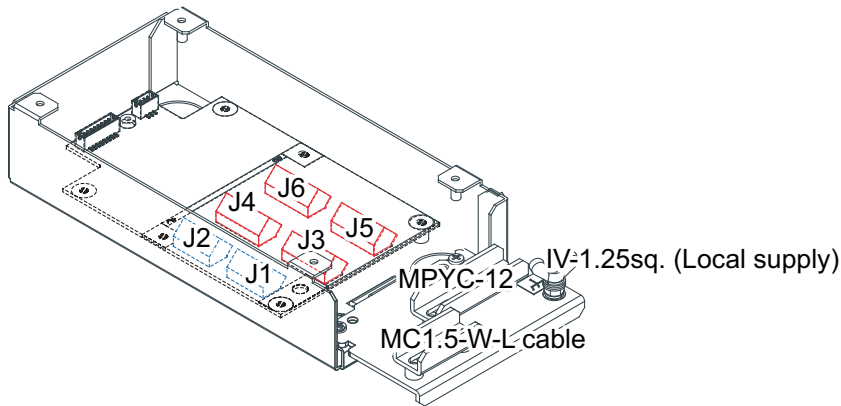

**Note:** The cable shield must lie in the cable clamp.

MC-3020D/3030D

**Input method (MC-3010A only)**

Select the method of the analog data input, power voltage or power current.

**Note 1:** The input must not exceed the range of the input voltage, to prevent malfunction.

-Setting for voltage input: -10V to +10V or 0 to 10V (depending on the setting)

-Setting for contact input: Voltage 4mA to 20mA

**Note 2:** When changing the input method, turn off the MC-3010A and on again to put change in effect.

- Power voltage: Input the amount of power voltage change to the operational amplifier.

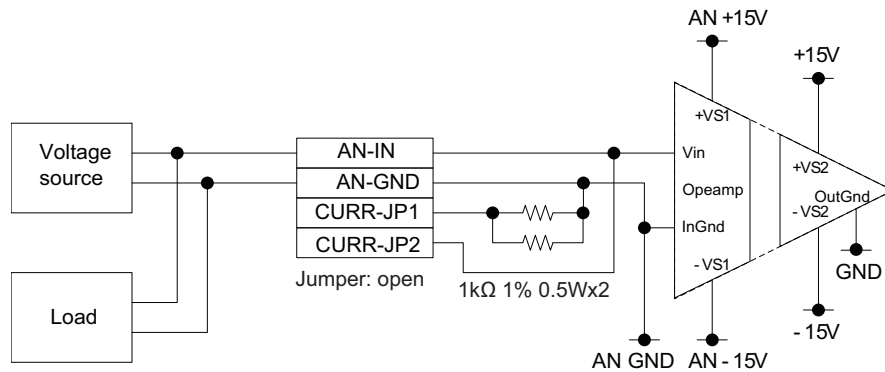



- Power current: Pass the power current to the shunt resistor, 1kΩ/parallel (combined resistance: 500Ω) to input the amount of voltage change at the both ends of the resistor to the operational amplifier.

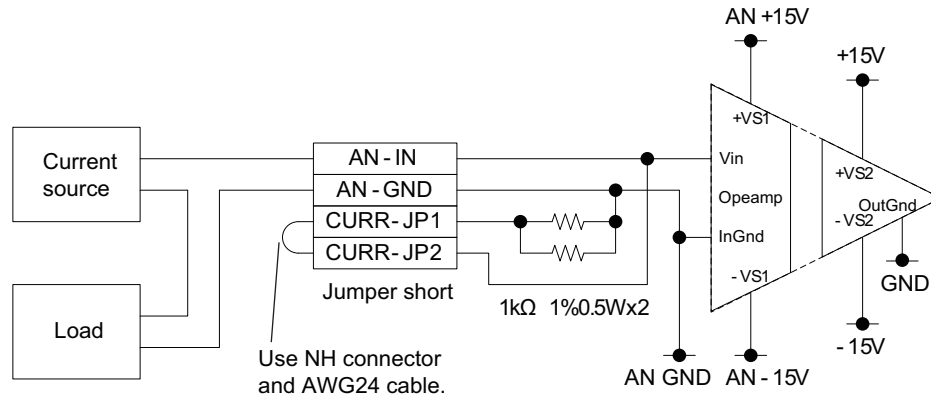

Connector J3

Pin #	Signal name	In/Out	Description	Power voltage	Power current
1	AN1_IN	In	Analog 1 input	TTYCS(LA)-1	
2	AN1_GND	-	Analog 1 GND		
3	CURR1_JP1	-	Analog 1 input, power current/voltage setting jumper 1	Pin #3-#4: open	Pin #3-#4: short
4	CURR1_JP2	-	Analog 2 input, power current/voltage setting jumper 1		

Connector J4

Pin #	Signal name	In/Out	Description	Power voltage	Power current
1	AN2_IN	In	Analog 2 input	TTYCS(LA)-1	
2	AN2_GND	-	Analog 2 GND		
3	CURR2_JP1	-	Analog 2 input, power current/voltage setting jumper 1	Pin #3-#4: open	Pin #3-#4: short
4	CURR2_JP2	-	Analog 2 input, power current/voltage setting jumper 1		

Connector J5

Pin #	Signal name	In/Out	Description	Power voltage	Power current
1	AN3_IN	In	Analog 3 input	TTYCS(LA)-1	
2	AN3_GND	-	Analog 3 GND		
3	CURR3_JP1	-	Analog 3 input, power current/voltage setting jumper 1	Pin #3-#4: open	Pin #3-#4: short
4	CURR3_JP2	-	Analog 3 input, power current/voltage setting jumper 1		

2. WIRING

**How to set ACK input (MC-3020D)**

Use the connectors J3 to J6 to set the ACK input for ACK1 to ACK8 as shown below.

- Input circuit for voltage input

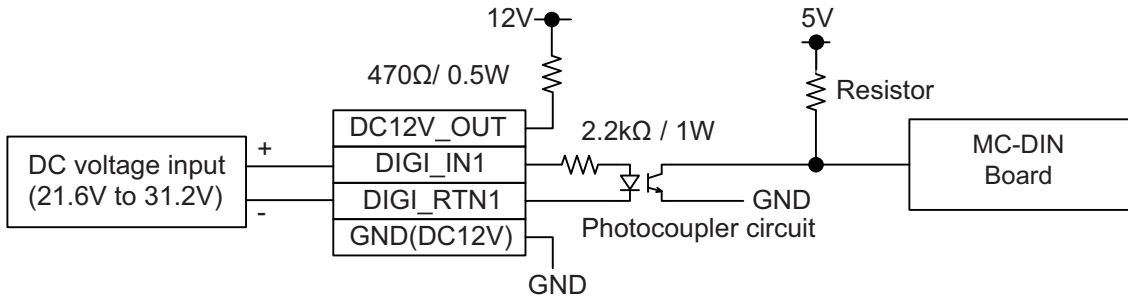

- Input circuit for contact input

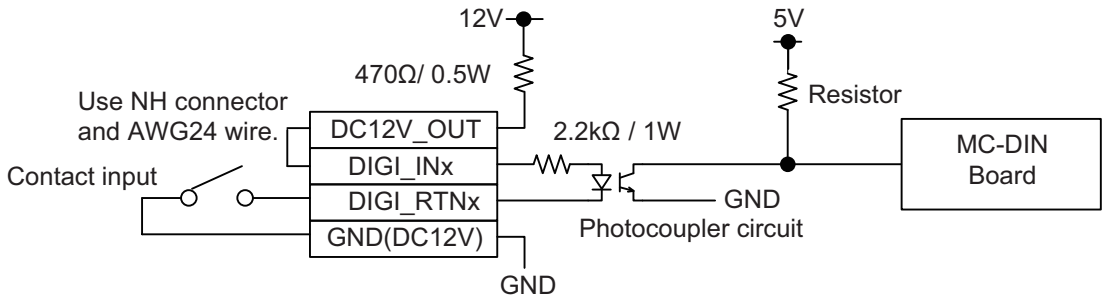

**Note 1:** The input must not exceed the range of the input voltage, to prevent malfunction.

- Setting for voltage input: 21.6V to 31.2V
- Setting for contact input: Voltage cannot be input (contact signal only).

**Note 2:** For analog input, see page 2-36.

Connector J3

Pin #	Signal name	In/Out	Remarks	ACK1 contact	ACK1 voltage	ACK2 contact	ACK2 voltage
1	DC12V_OUT	Out	ACK1 In	Pin #1-#2: short MPYC-12	No connection	According to ACK1 input	
2	DIGI_IN1	In			MPYC-12		
3	DIGI_RTN1	Out			No connection		
4	GND (DC12V)	In					
5	DC12V_OUT	Out	ACK2 In	According to ACK2 input		Pin #5-#6: short	No connection
6	DIGI_IN2	In				MPYC-12	
7	DIGI_RTN2	Out					
8	GND (DC12V)	In					No connection

Connector J4

Pin #	Signal name	In/Out	Remarks	ACK3 contact	ACK3 voltage	ACK4 contact	ACK4 voltage
1	DC12V_OUT	Out	ACK3 In	Pin #1-#2: short	No connection	According to ACK3 input	
2	DIGI_IN3	In			MPYC-12		
3	DIGI_RTN3	Out			MPYC-12		
4	GND (DC12V)	In		No connection			
5	DC12V_OUT	Out	ACK4 In	According to ACK4 input		Pin #5-#6: short	No connection
6	DIGI_IN4	In				MPYC-12	MPYC-12
7	DIGI_RTN4	Out					
8	GND (DC12V)	In					No connection

Connector J5

Pin #	Signal name	In/Out	Remarks	ACK5 contact	ACK5 voltage	ACK6 contact	ACK6 voltage
1	DC12V_OUT	Out	ACK5 In	Pin #1-#2: short	No connection	According to ACK5 input	
2	DIGI_IN5	In			MPYC-12		
3	DIGI_RTN5	Out			MPYC-12		
4	GND (DC12V)	In		No connection			
5	DC12V_OUT	Out	ACK6 In	According to ACK6 input		Pin #5-#6: short	No connection
6	DIGI_IN6	In				MPYC-12	MPYC-12
7	DIGI_RTN6	Out					
8	GND (DC12V)	In					No connection

Connector J6

Pin #	Signal name	In/Out	Remarks	ACK7 contact	ACK7 voltage	ACK8 contact	ACK8 voltage
1	DC12V_OUT	Out	ACK1 In	Pin #1-#2: short	No connection	According to ACK7 input	
2	DIGI_IN7	In			MPYC-12		
3	DIGI_RTN7	Out			MPYC-12		
4	GND (DC12V)	In		No connection			
5	DC12V_OUT	Out	ACK2 In	According to ACK8 input		Pin #5-#6: short	No connection
6	DIGI_IN8	In				MPYC-12	MPYC-12
7	DIGI_RTN8	Out					
8	GND (DC12V)	In					No connection

2. WIRING

**How to set alarm output (MC-3030D)**

Use the connector J3 to J6 on the MC\_OUT Board (24P0117) to select NC (normal close) or NO (normal open) for alarm output 1 to 8.

Connector J3

Pin #	Signal name	In/Out	Remarks	Alarm1 NO Out	Alarm1 NC Out	Alarm2 NO Out	Alarm2 NC Out
1	A1	Out	Alarm1 Out	MPYC-12	No connection	-	
2	COM1				MPYC-12		
3	B1			No connection			
4	A2		Alarm2 Out	-		MPYC-12	No connection
5	COM2					MPYC-12	
6	B2				No connection		

Connector J4

Pin #	Signal name	In/Out	Remarks	Alarm3 NO Out	Alarm3 NC Out	Alarm4 NO Out	Alarm4 NC Out
1	A3	Out	Alarm3 Out	MPYC-12	No connection	-	
2	COM3				MPYC-12		
3	B3			No connection			
4	A4		Alarm4 Out	-		MPYC-12	No connection
5	COM4					MPYC-12	
6	B4				No connection		

Connector J5

Pin #	Signal name	In/Out	Remarks	Alarm5 NO Out	Alarm5 NC Out	Alarm6 NO Out	Alarm6 NC Out
1	A5	Out	Alarm5 Out	MPYC-12	No connection	-	
2	COM5				MPYC-12		
3	B5			No connection			
4	A6		Alarm5 Out	-		MPYC-12	No connection
5	COM6					MPYC-12	
6	B6				No connection		

Connector J6

Pin #	Signal name	In/Out	Remarks	Alarm7 NO Out	Alarm7 NC Out	Alarm8 NO Out	Alarm8 NC Out
1	A7	Out	Alarm7 Out	MPYC-12	No connection	-	
2	COM7				MPYC-12		
3	B7			No connection			
4	A8		Alarm8 Out	-		MPYC-12	No connection
5	COM8					MPYC-12	
6	B8				No connection		

**Case gasket OP24-29**

The optional kit OP24-29 protects the connectors on the MC-3010A/3020D/3030D to waterproofing standard IPX2.

*Case gasket (type: OP24-29, code no.: 001-169-960)*

Name	Type	Code No.	Qty	Remarks
Case gasket (analog)	24-014-2052-1	100-367-961-10	2	MC-3010A/3020D/3030D

1. Unfasten four binding screws to remove the cover from the adapter.

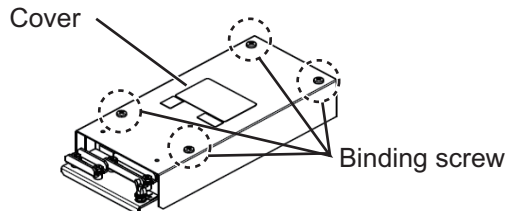

2. Peel the paper from the case gasket, then attach the case gasket to the reverse side of the cover and the body unit as shown below.

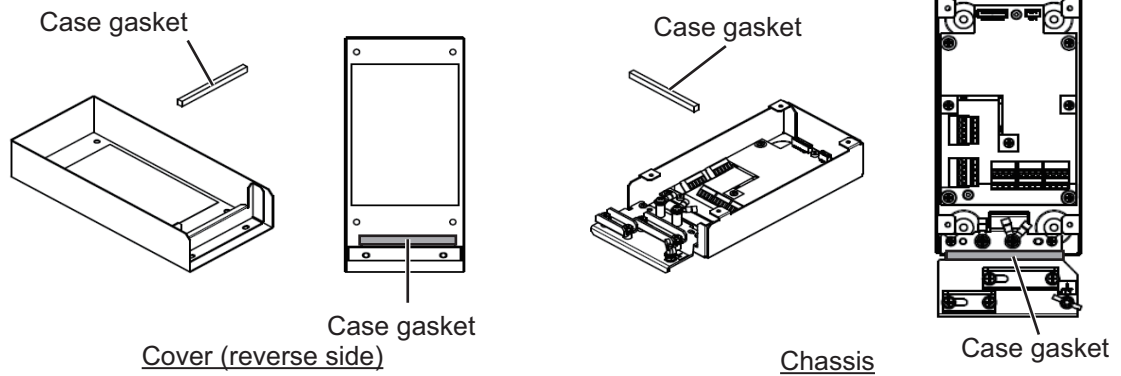

3. Attach the cover to the MC-3010A/3020D/3030D chassis.

### 2.6.3 How to set jumper blocks in the sensor adapters

#### **MC-3000S**

Set the jumper blocks on the MC-CS Board (24P0114) referring to the tables that follow.

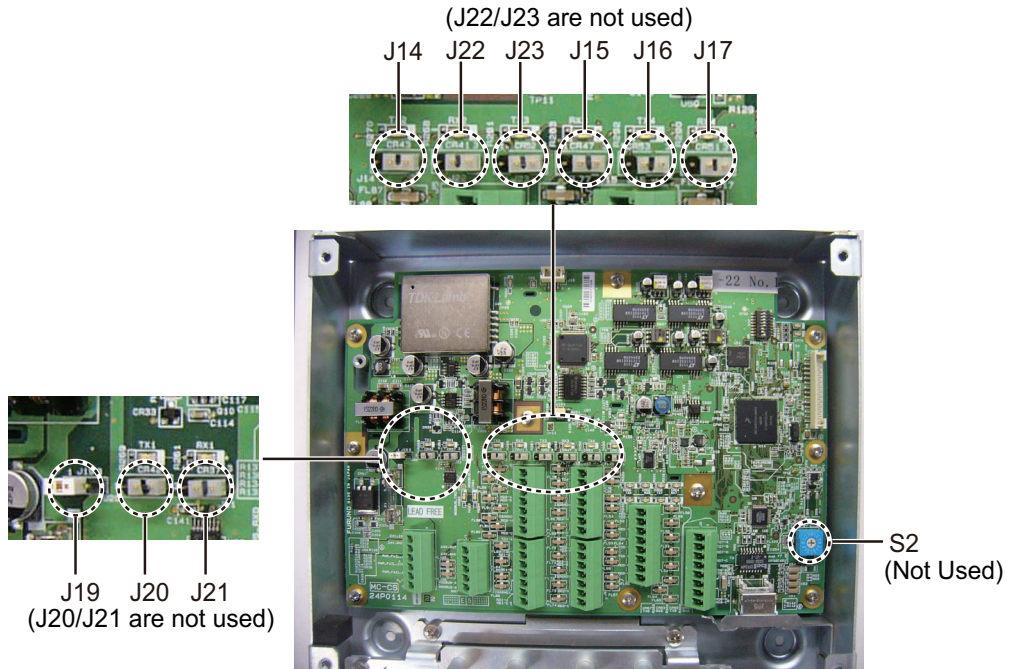

MC-CS Board (24P0114)

**Jumper block:** Use the jumper block J19 to set the termination resistor on/off for the MODBUS communication on the connector J1. For the first and last sensor adapter in a series, their termination resistors must be set to ON. Use the MC-CS Board with the default setting because it becomes the "first" adapter in a series.

Jumper block J19		Connector J1
1-2	SHORT	Termination resistor: ON (default setting)
2-3	OPEN	
1-2	OPEN	Termination resistor: OFF
2-3	SHORT	

Set the jumper blocks J14 through J17 to turn the termination resistors on connectors J4 through J7, respectively.

(Termination resistor ON)

- When setting the starting/ending terminal for the multipoint, or the multipoint is not connected (CH1 to 4).

(Terminal resistor OFF)

- When setting the terminal other than starting/ending for the multipoint (CH1 to 4).

Jumper block J14		Connector J4 (CH1)
1-2	SHORT	Termination resistor: ON (default setting)
2-3	OPEN	
1-2	OPEN	Termination resistor: OFF
2-3	SHORT	

Jumper block J15		Connector J5 (CH2)
1-2	SHORT	Termination resistor: ON (default setting)
2-3	OPEN	
1-2	OPEN	Termination resistor: OFF
2-3	SHORT	

Jumper block J16		Connector J6 (CH3)
1-2	SHORT	Termination resistor: ON (default setting)
2-3	OPEN	
1-2	OPEN	Termination resistor: OFF
2-3	SHORT	

Jumper block J17		Connector J7 (CH4)
1-2	SHORT	Termination resistor: ON (default setting)
2-3	OPEN	
1-2	OPEN	Termination resistor: OFF
2-3	SHORT	

### **MC-3010A/3020D/3030D**

This paragraph shows how to set the MC-ANLG Board (24P0115, for MC-3010A), MC-DIN Board (24P0116, for MC-3020D) and MC-DOUT Board (24P0117, for MC-3030D).

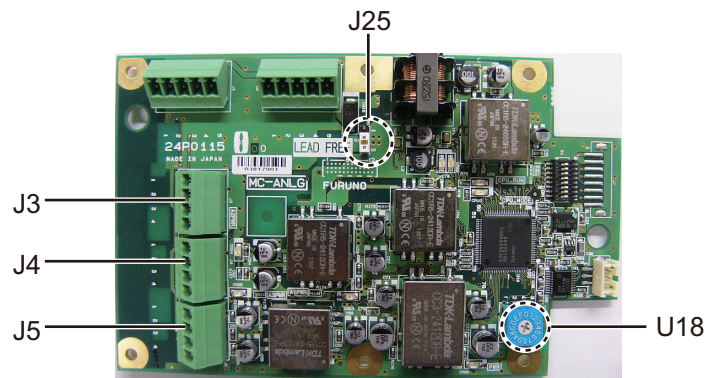

MC-ANLG Board (24P0115)

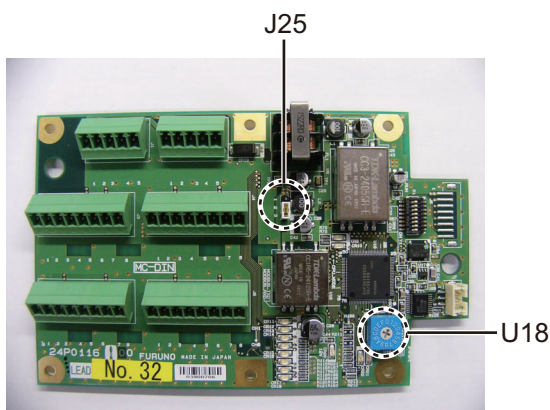

MC-DIN Board (24P0116)

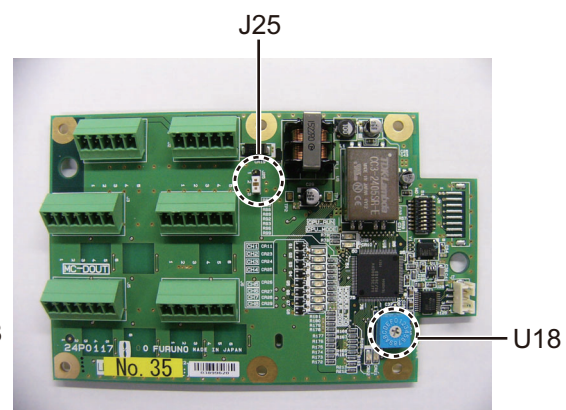

MC-DOUT Board (24P0117)

**Rotary switch:** Use the rotary switch (U18) to set the MODBUS address with a digit of number from "0". When multiple sensor adapters are connected to the MC-3000S, the same number cannot be used among them. (It is allowed to use the same number between the MC-3000S and a sensor adapter.)

**Jumper block:** Use the jumper block J25 to set the termination resistor on/off for the MODBUS communication on the connector J1. For the first and last sensor adapter in a series, their termination resistors must be set to ON. If not, communication between sensor adapters is not possible.

Jumper block J25		Connector J1
1-2	OPEN	Termination resistor: OFF (default setting)
2-3	SHORT	
1-2	SHORT	Termination resistor: ON
2-3	OPEN	

## 2.7 LAN Signal Converter Kit (option)

The optional LAN Signal Converter OP03-223-3 (code: 001-254-380) allows the use of existing antenna cable RW-9600, or enables installation of the antenna unit on the foremast, using antenna cable RW-9600.

### 2.7.1 Application overview

The LAN Signal Converter has two applications.

#### Application 1: Use with existing antenna cable (retrofit)

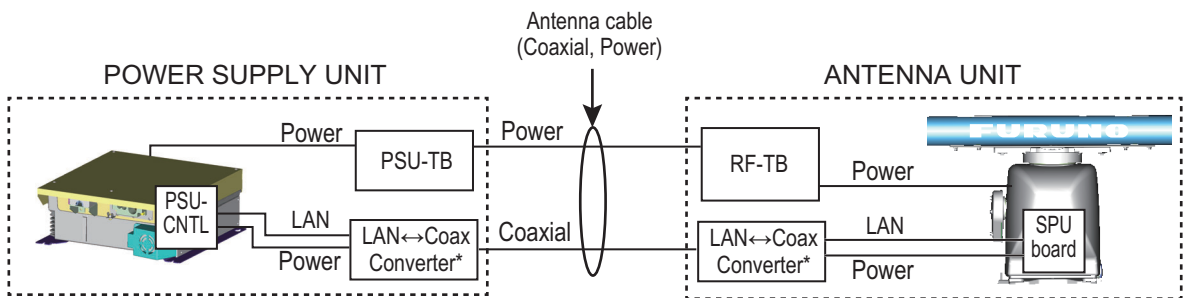

\* Installed inside respective unit.

#### Method 1: Using existing antenna cable (RW-9600)

Use with existing antenna cable (RW-9600) in case of retrofit. The maximum length of the antenna cable is 100 m.

The white, red, and green wires are not used. Attach a single crimp-on lug (FV5.5-S4(LF), yellow) locally to the wires. (These wires will be connected together with the shield of the power line, in the next section.)

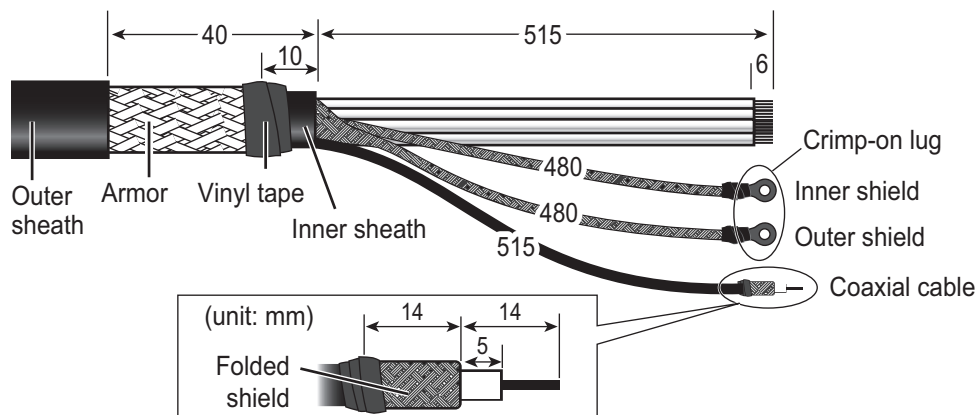



**Application 2: Foremast installation**

Foremast installation, where the distance between the antenna unit and the power supply unit is more than 100 m (max. 460 m). See section 2.8 and the interconnection diagram for connections in the junction box.

The Cable Extension Kit (Type: OP03-224-3, Code No.: 001-254-410), comprised of two junction boxes, two LAN Signal Converters and necessary hardware, is optionally available.

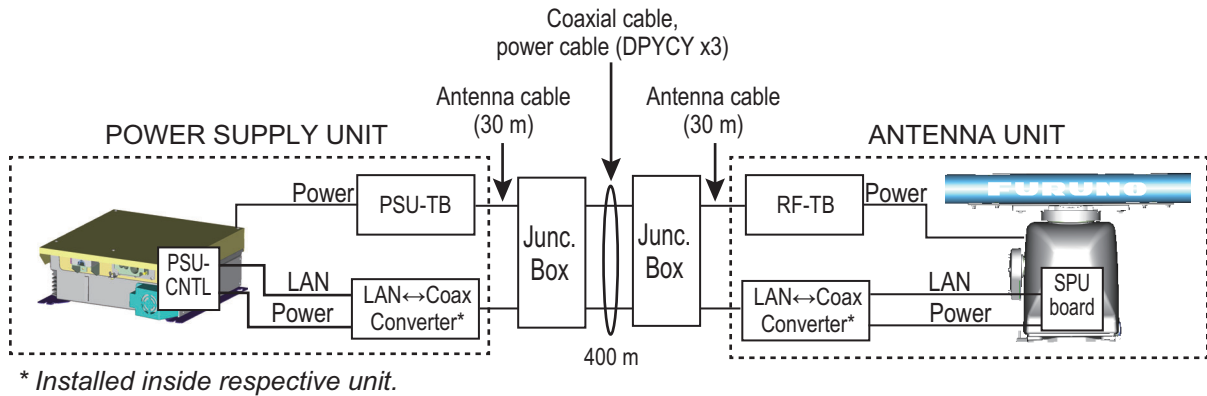

Method 2: Using antenna cable RW-9600 (new)

**2.7.2 Installation in the antenna unit**

Dismount the transceiver unit. See section 2.2.2 for the procedure.

1. Set the M\_S switch on the converter to the S (Slave) position.
2. Fasten the BNC case to its mounting plate with two screws.

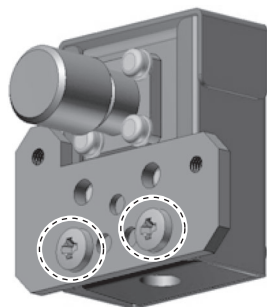
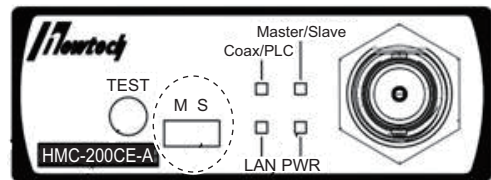

3. Loosen two screws on the BNC case. Attach the coaxial cable of the antenna cable then close the case.

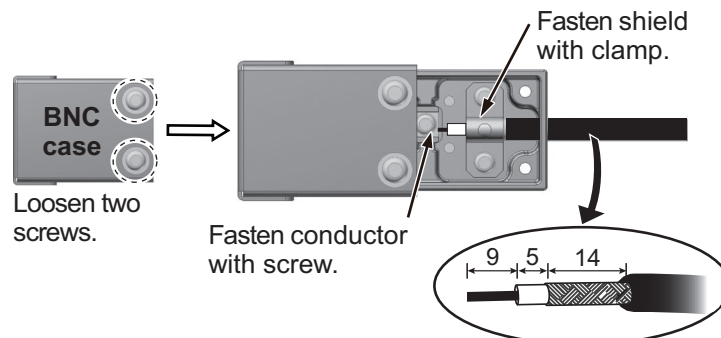

## 2. WIRING

4. Fasten the BNC case to the antenna unit with two screws. Connect the coaxial cable to the BNC case then pass it through the locking wire saddle circled below.

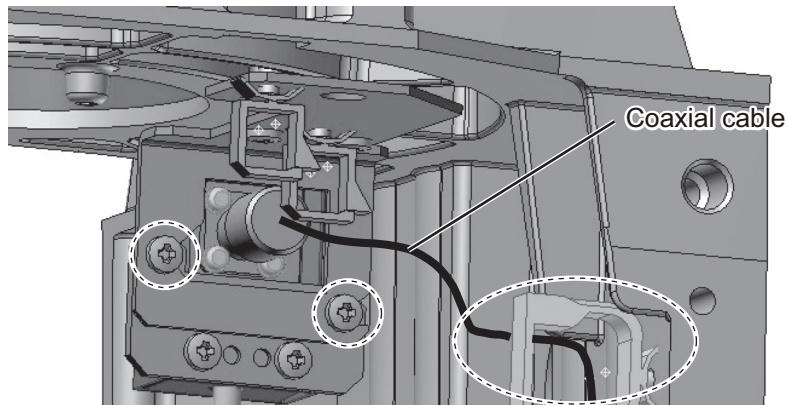

5. Fasten the converter to the transceiver unit with four screws at the locations circled below.

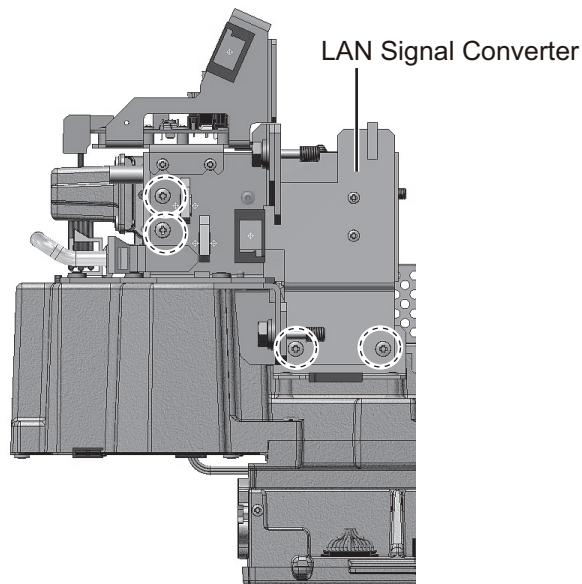

6. Unfasten the two screws from the cover plate that hides the SPU board. Connect the power cable (supplied) to the converter. Pass the cable through the two locking wire saddles circled below then connect the cable to J824 on the SPU board. Close the cover plate.

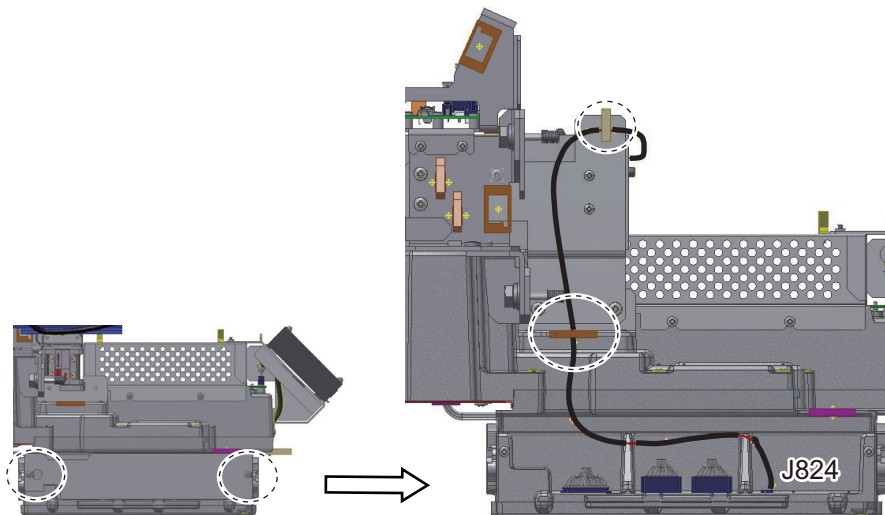

7. Connect the LAN cable to the LAN port on the converter. Pass the cable through the four locking wire saddles circled below then connect the cable to J821 on the SPU board.

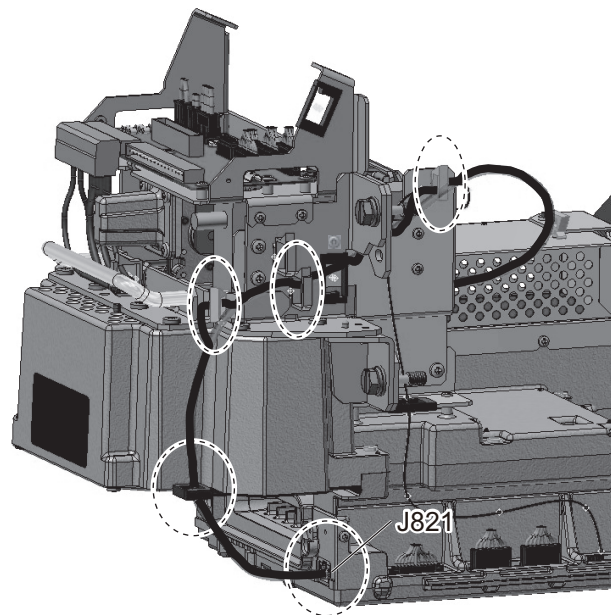

8. Mount the transceiver unit. Connect the coaxial cable from the BNC case to the converter.

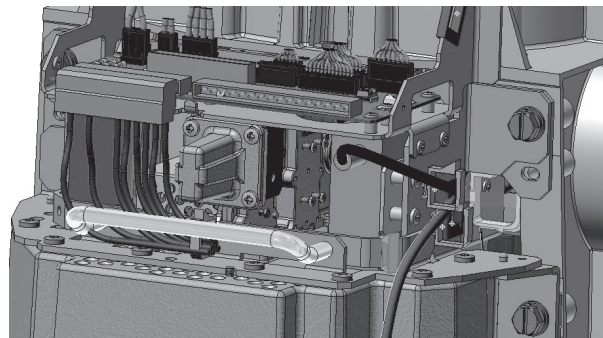

### 2.7.3 Installation in the power supply unit

Some parts or wiring may have been omitted from the illustrations of the power supply unit for clarity.

1. Set the M\_S switch on the converter to the M (Master) position.

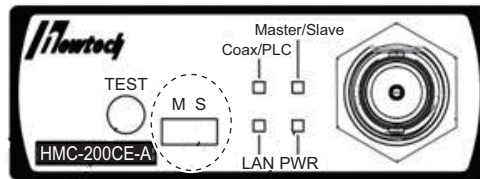

2. Fasten the converter to its mounting bracket with four screws.

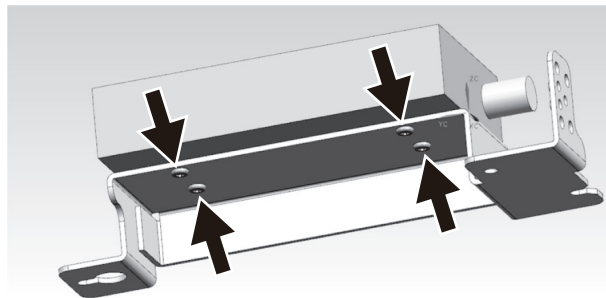

3. Loosen two screws on the BNC case. Attach the coaxial cable from the antenna cable then close the case.

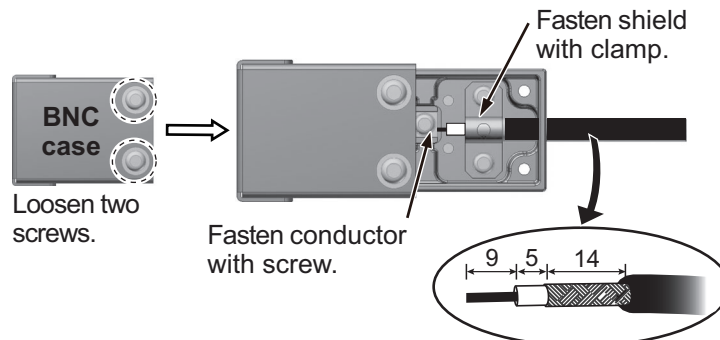

4. Fasten the BNC case to the mounting bracket with two screws.

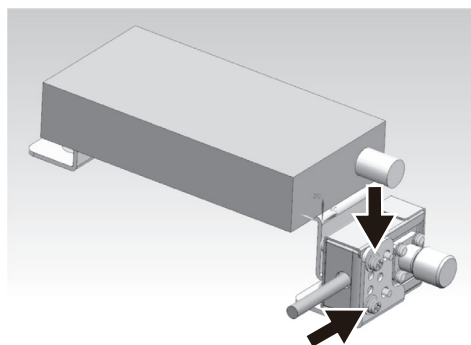

5. Pass the LAN cable thru the clamp circled below then connect it to J102 on the PSU-CNTL board. (The cable will be connected to the converter after the converter is installed.)

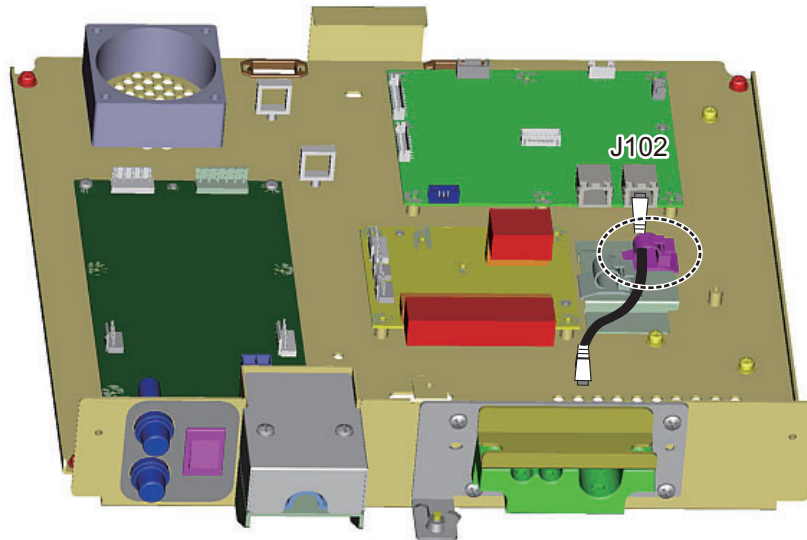

6. Fasten the converter with three screws at the locations shown circled below. Attach the two supplied locking wire saddles to the locations circled below.

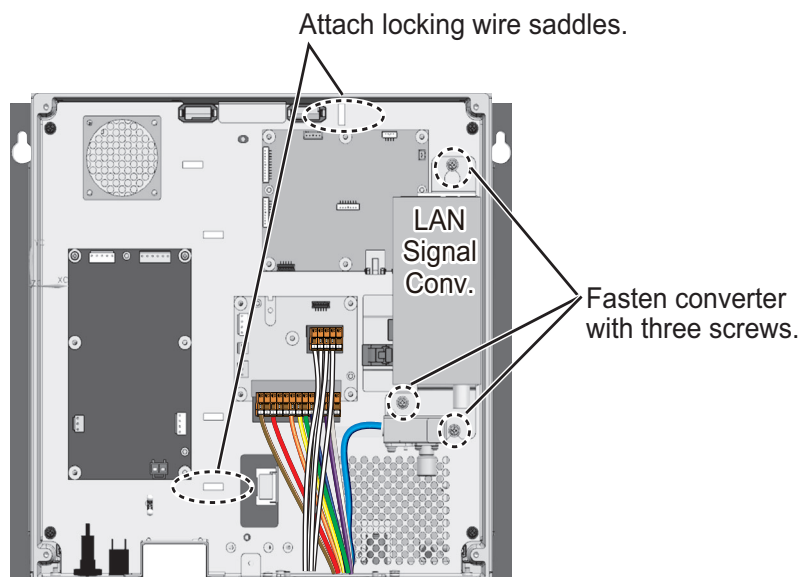

7. Connect the LAN, power and coaxial cables as shown below.
  - Pass the LAN cable through the four locking wire saddles circled in the figure on the next page then connect it to the LAN port on the converter.
  - Connect the power cable (supplied) between the converter and J107 on the PSU-CNTL Board.
  - Connect the coaxial cable between the converter and the BNC case.

## 2. WIRING

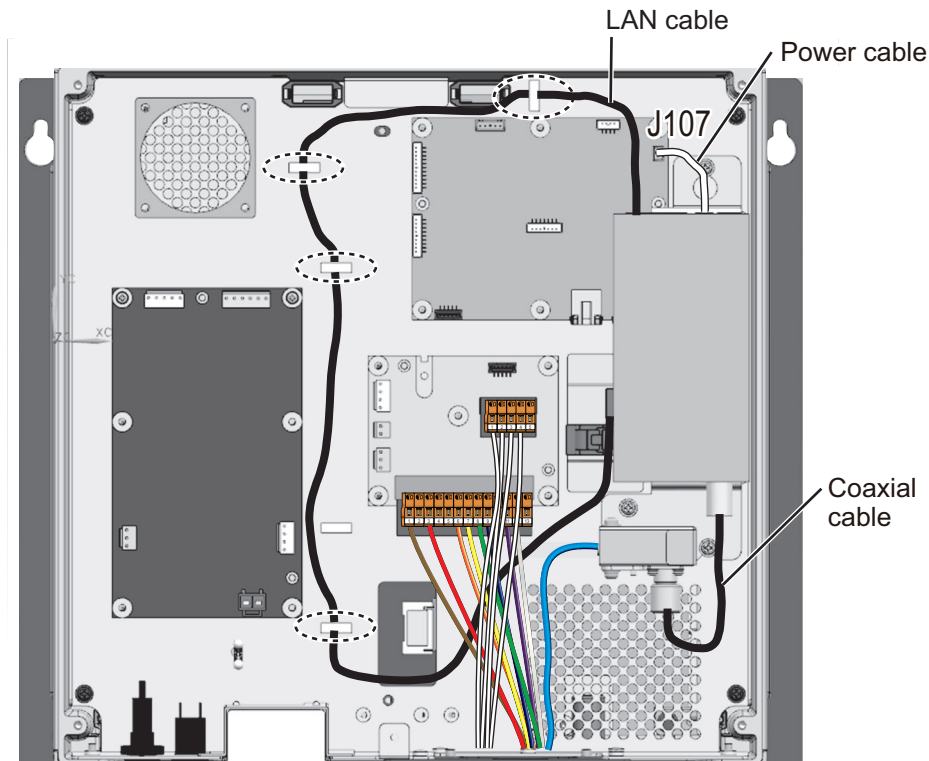

### 2.7.4 How to check the installation

Observe the LEDs on the converter to check for proper operation, troubleshoot.

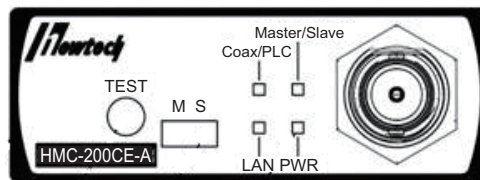

LED	State	Meaning
PWR	OFF	Power OFF
	Lighting green	Power ON
	Flashing orange	Test mode
LAN	OFF	Link down
	Lighting green	100 M link up
	Flashing green	100 M active
	Lighting orange	10 M link up
	Flashing orange	10 M active
Coax/PLC	OFF	Link down
	Lighting green	Link up
Master/Slave	Lighting green	Master mode
	Lighting orange	Slave mode

**Note:** The TEST button is for factory use. Do not operate the button.

## 2.8 Junction Box (option)

Junction boxes are required when the distance between the antenna unit and power supply unit is greater than 100 meters (max. 460 meters); for example, the antenna unit is installed on the foremast. Use signal cable RW-9600(x2), power cable DPYCY-6(x3), and coaxial cable RG-12/UY(x3).

Pass each cable through its cable gland as shown below.

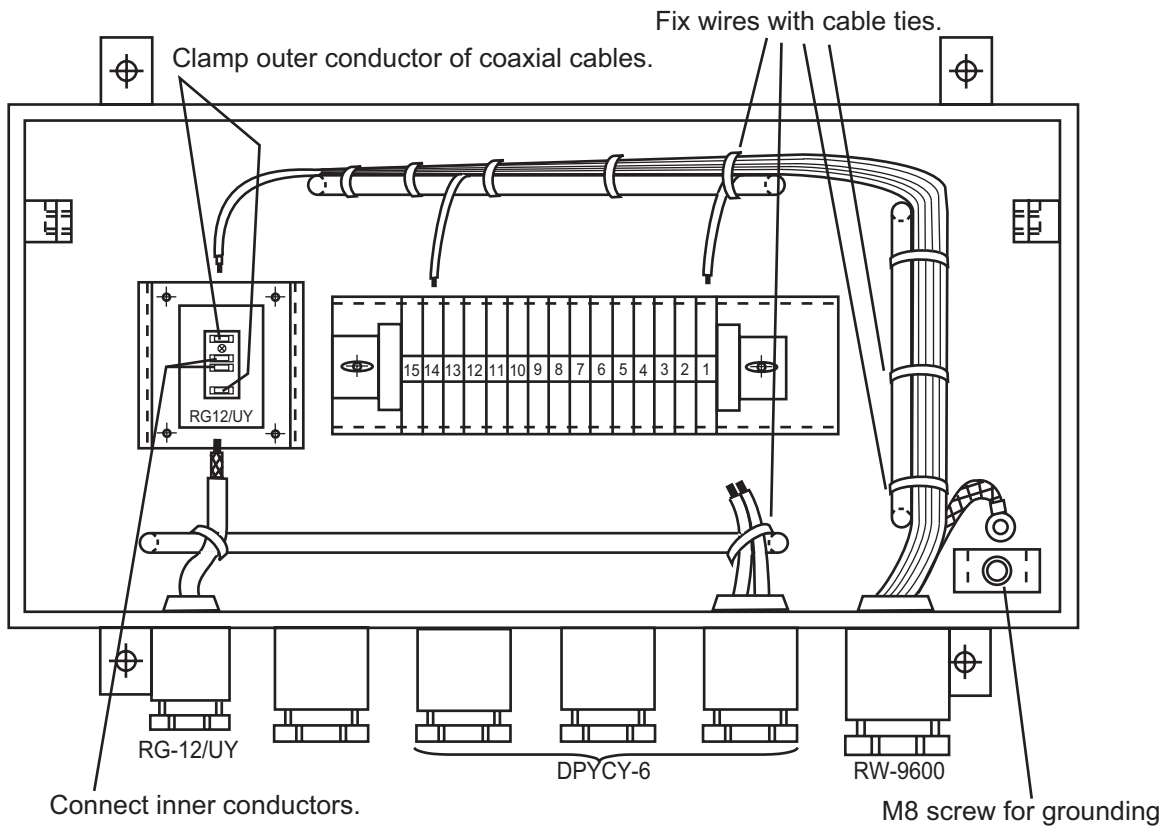
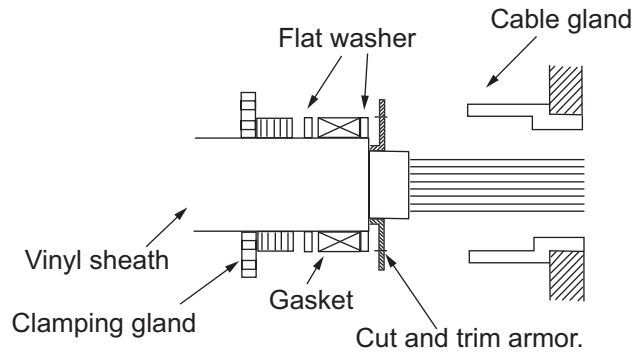

## 2. WIRING

Connect the RW-9600 cable as shown below. Refer also to the interconnection diagram.

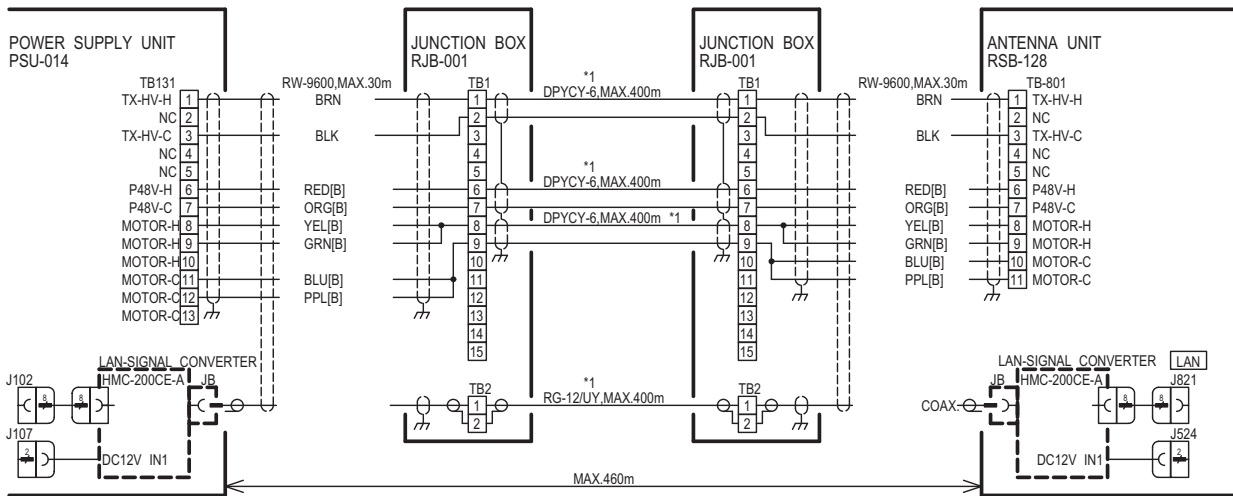

The table below shows the wire colors for the RW-9600.

Power Supply Unit		Antenna Unit	
TB131	Cable RW-9600	TB801	Cable RW-9600
1	Brown	1	Brown
3	Black	3	Black
6	Red*	6	Red*
7	Orange*	7	Orange*
8	Yellow*	8	Yellow*
9	Green*	9	Green*
10	-	10	Blue*
11	Blue*	11	Purple*
12	Purple*		

\* Thick



## 2.9 Intelligent HUB (option)

Fix the LAN cables to the cable clamp with the cable ties (supplied).

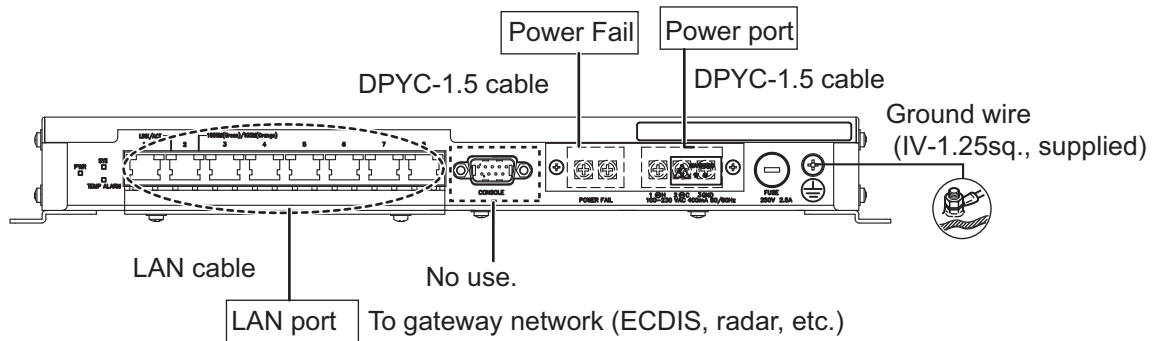

Attach the LAN cap (supplied) to the unused connector holes to comply with waterproofing standard IPX2.

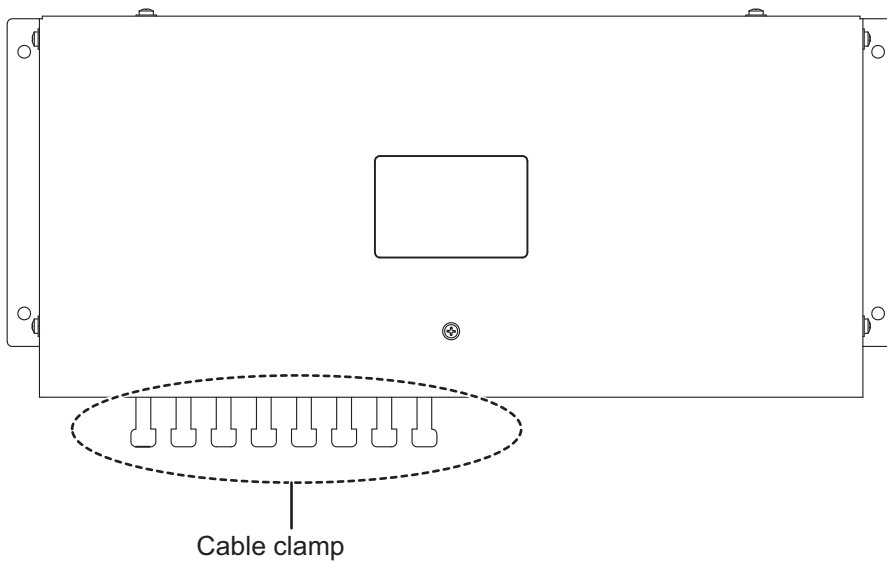

## 2.10 How to Extend the Control Unit Cable (option)

To extend the length of the cable between the control unit and the processor unit, use the appropriate cable assembly for the control unit, as listed below.

- RCU-025: TET-16-045A (5/10/20/30 m)
- RCU-026: 6TPSH-XH12X2-LxxSP2 (5/10/20/30 m)

**Note:** When the control unit cable is 10 m or longer, the USB cable (TS-20-071-1, 5 m) that is supplied with the control unit cannot be used. Even if the USB cable is not used, you can operate the control unit properly, but the USB port on the control unit is deactivated.

### 2.10.1 Radar control unit (RCU-025)

#### Wiring for the control unit

1. Unfasten 12 binding screws (M3x8) from the bottom of the control unit to remove the cover.

**Note:** Do not add stress to the cables connected to the control unit board when removing the cover. When the serial number of the control unit is “200001” or later, disconnect the cable from the J3 (see the figure on step 3) before removing the cover.

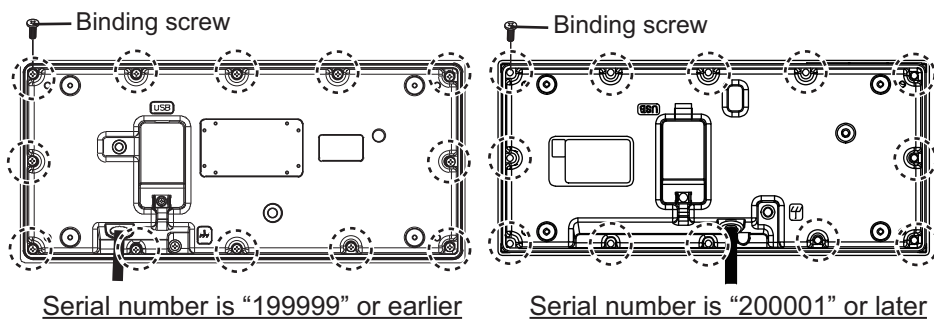

2. Unfasten two screws to remove the cable clamp.
3. Release the control unit cable from the wiring clamp, then disconnect the cable from the J1.

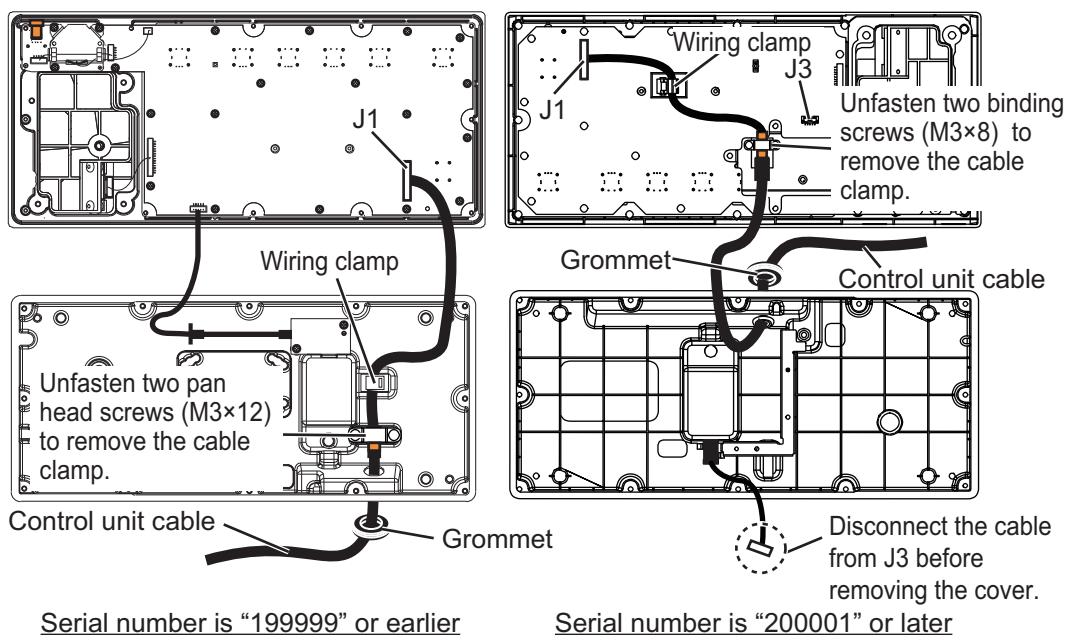

4. Pull out the control unit cable from the cover.
5. Pass the optional cable assy (TET-16-045A) through the grommet and cable entrance on the control unit.
6. Fasten the shield of the cable with the cable clamp (removed at step 2).

**Note:** When the serial number is “200001” or later, fasten the shield as shown in the figure to the right.

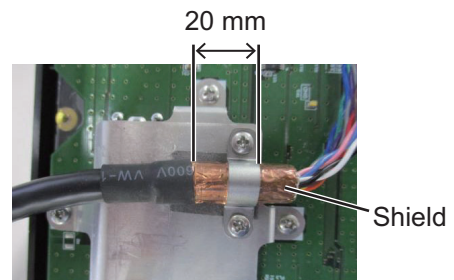

7. Connect the cable to the J1, then secure the cable with the wiring clamp.
8. Reattach the control unit cover.

**Wiring for the processor unit**

1. Unfasten four screws (M4×8) to remove the processor unit cover.
2. Unfasten the three bolts circled in the figure below to remove the cable clamp (upper).

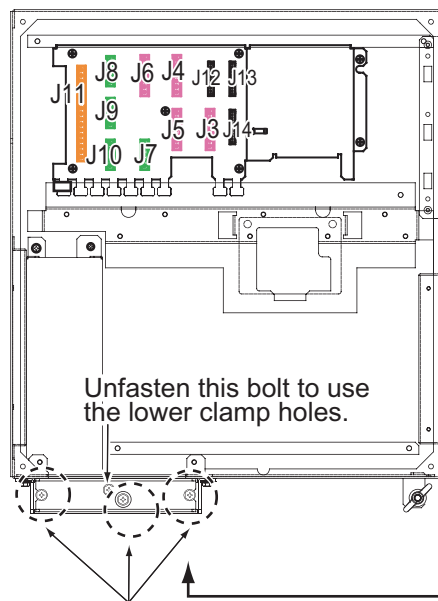

J3 to J6: IEC 61162-1/2  
 J7 to J10: IEC 61162-1  
 J11: Alarm system (System fail, Power fail, Normal close×2, Normal open×2, ACK IN)  
 J12: Main control unit  
 J13 and J14: Sub control units

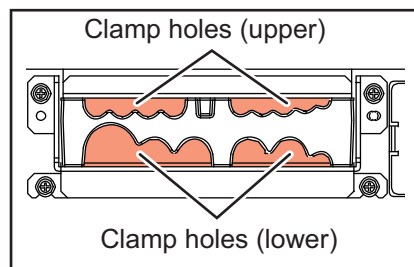

Unfasten these three bolts to remove the upper plate.

3. Disconnect the control unit cable from the processor unit, then connect the cable assy (TET-16-045A).
4. Set the shield part of cables under the cable clamp then tighten the cable clamp.



Lay shields of cables under this clamp then tighten the clamp.

5. Attach the processor unit cover.

## 2.10.2 Trackball control unit (RCU-026)

### Wiring for the trackball control unit

1. Unfasten four binding screws (M3×8) from the bottom of the control unit, and a pan head screw (M3×8) and flat washer from the back of the control unit to remove the cover.

**Note:** Remove the cover slowly to prevent damage to the cables connected to the circuit board in the control unit.

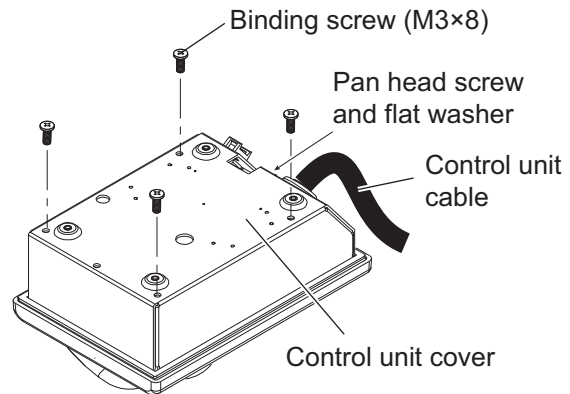

2. Remove the cable clamp from the control unit, then disconnect the control unit cable from the J1 connector.

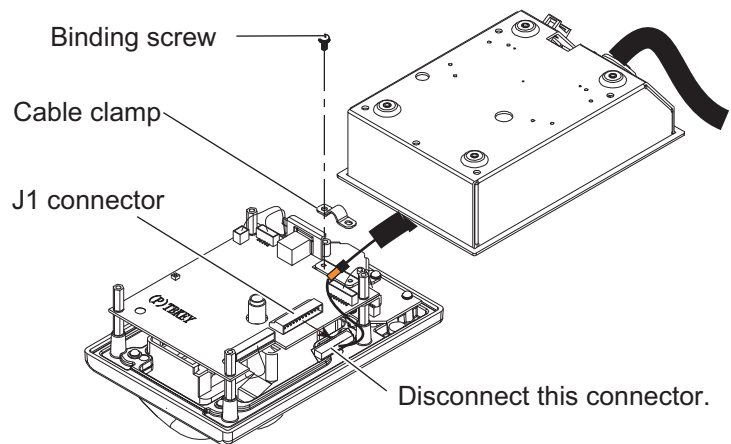

3. Pull out the control unit cable from the cover.
4. Pass the optional cable assy (6TPSH-XH12X2-LxxSP2) through the cable hole on the cover.

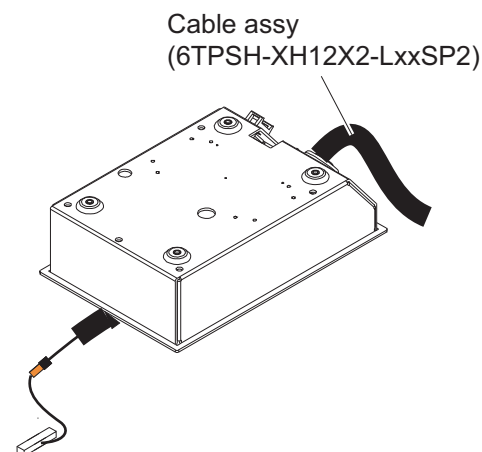

- Fasten the shield of the cable assy with the cable clamp (removed at step 2), then connect the connector at the end of the cable assy to the J1 on the circuit board.  
**Note:** The shield of the cable must not touch the circuit board.

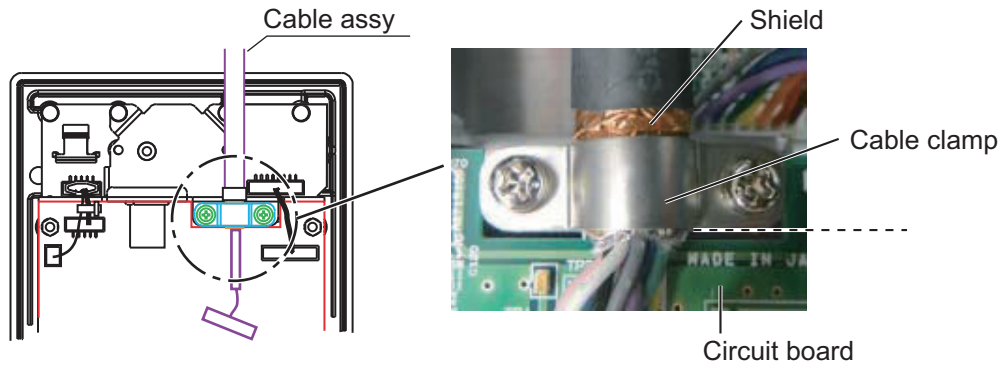

- Reattach the control unit cover.

**Wiring for the processor unit**

- Unfasten four screws (M4×8) to remove the processor unit cover.
- Unfasten the three bolts circled below to remove the cable clamp (upper) as shown below.

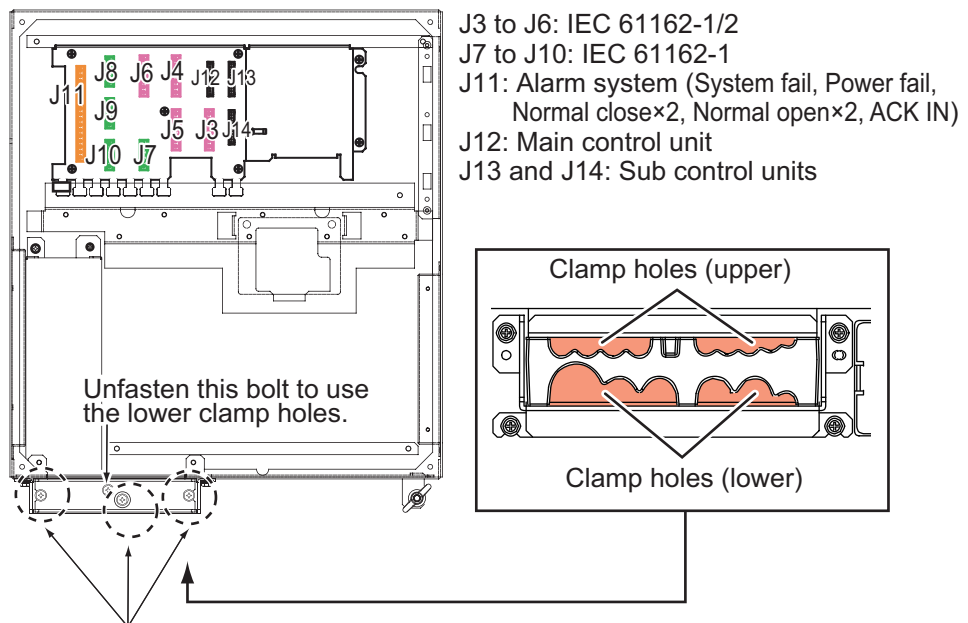

- Unfasten these three bolts to remove the upper plate.
- Disconnect the control unit cable from the processor unit, then connect the cable assy (6TPSH-XH12X2-LxxSP2).
- Set the shields of cables under the cable clamp then tighten the cable clamp.

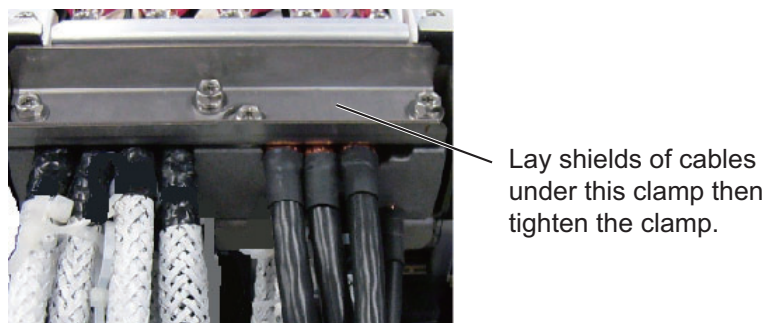

- Remount the processor unit cover.

## 2. WIRING

This page is intentionally left blank.

# 3. SETTINGS AND ADJUSTMENTS

**Note:** After completing the settings and adjustments, copy the setting data to a USB flash memory, referring to section 23.2 in the Operator's Manual. This will allow easy restoration of setting data after the SPU Board is replaced, etc.

## 3.1 How to Access the Radar Installation Menu

The [RADAR INSTALLATION] menu has various items for adjustment of the radar. To show this menu, press the **MENU** key five times while pressing and holding the **1 HL OFF** key.

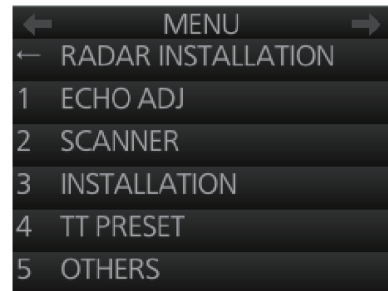

### Tuning initialization

Right click the [TUNE] button on the InstantAccess bar™ then select [Tune Initialize] to start initialization. "TUNE IN" appears during the initialization.

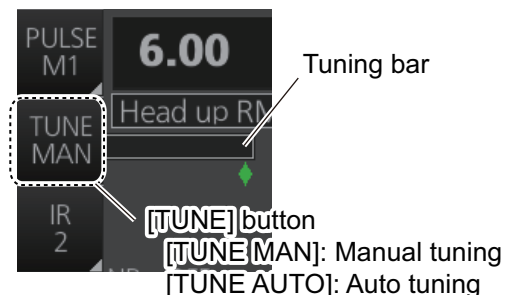

## 3.2 How to Align the Heading

You have mounted the antenna unit facing straight ahead in the direction of the bow. Therefore, a small but conspicuous target dead ahead visually must appear on the heading line (zero degrees).

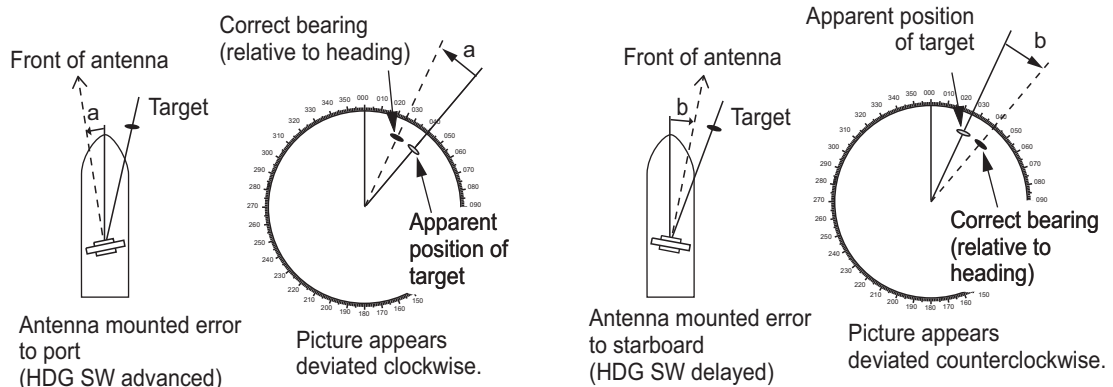

In practice, you will probably observe some small bearing error on the display because of the difficulty in achieving accurate initial positioning of the antenna unit. The following adjustment will compensate for this error.

### 3. SETTINGS AND ADJUSTMENTS

1. Select a stationary target echo at a range between 0.125 and 0.25 NM, preferably near the heading line.
2. Operate the EBL control to bisect the target echo.
3. Read the target bearing.
4. Measure the bearing of the stationary target on a navigation chart and calculate the difference between the actual bearing and apparent bearing on the radar screen.
5. Show the [RADAR INSTALLATION] menu.
6. Select [1 ECHO ADJ] followed by [2 HD ALIGN].
7. Key in the bearing difference. The setting range is 0° to 359.9°.
8. Confirm that the target echo is displayed at the correct bearing on the screen.

## 3.3 How to Adjust the Sweep Timing

Sweep timing differs with respect to the length of the signal cable between the antenna unit and the processor unit. Adjust sweep timing at installation to prevent the following symptoms:

- The echo of a "straight" target (for example, pier), on the 0.25 NM range, appears on the display as being pulled inward or pushed outward. See the figure below.

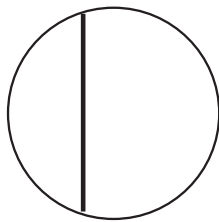

(1) Correct

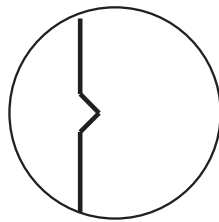

(2) Target pushed inward

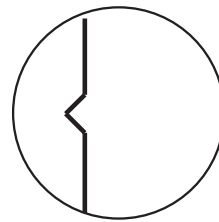

(3) Target pushed outward

- The range of target echoes is also be incorrectly shown.
  1. Transmit on the 0.25 NM range.
  2. Adjust the radar picture controls to display the picture properly.
  3. Select a target echo which should be displayed straightly.
  4. Show the [RADAR INSTALLATION] menu, then select [1 ECHO ADJ] followed by [3 TIMING ADJ].
  5. Set a value which displays the target straightly. The setting range is 0 to 4095.



## 3.4 How to Suppress Main Bang

Main bang is the clutter at the center of the screen that you typically see on the radar display, and it may mask close-in targets. If main bang appears at the screen center, suppress it as follows.

1. Transmit the radar on a long range and then wait ten minutes.
2. Adjust the gain to show a slight amount of noise on the display.
3. Select the 0.25 NM range, and turn off the **A/C SEA** control.
4. Show the [RADAR INSTALLATION] menu, then select [1 ECHO ADJ] followed by [4 MBS].
5. Set a value that causes the main bang to just disappear. The setting range is 0 to 255.

## 3.5 Dual Radar Display

The dual radar display, available with the B-type specification radar, shows radar images from two radar sources on one radar display. Any combination of X- and S-band radars is possible.

**Note:** The [RADAR INSTALLATION] menu is inoperative (grayed out on the installation menu) when the dual radar display is active.

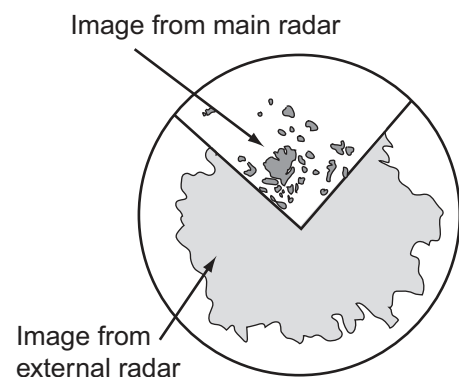

### 3.5.1 How to enable, disable the dual radar display

1. Open the [RADAR INSTALLATION] menu, then select [OTHERS] menu.
2. Select [5 COMBINE FUNC].
3. Select [OFF] or [ON] as appropriate.

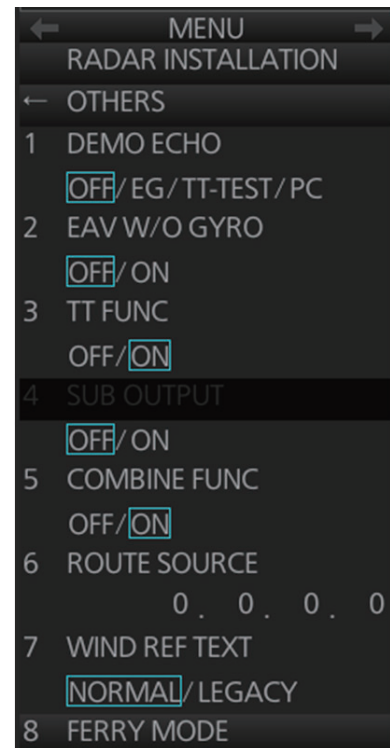

### 3.5.2 How to set the width and length for the picture from the external radar

If two FAR-3xx0 series radars are to be used for the dual radar display, set the same display area on each radar to ensure proper performance.

1. Open the [RADAR INSTALLATION] menu, then select [2 SCANNER], [6 DUAL RADAR SETTING] to show the [DUAL RADAR SETTING] menu.

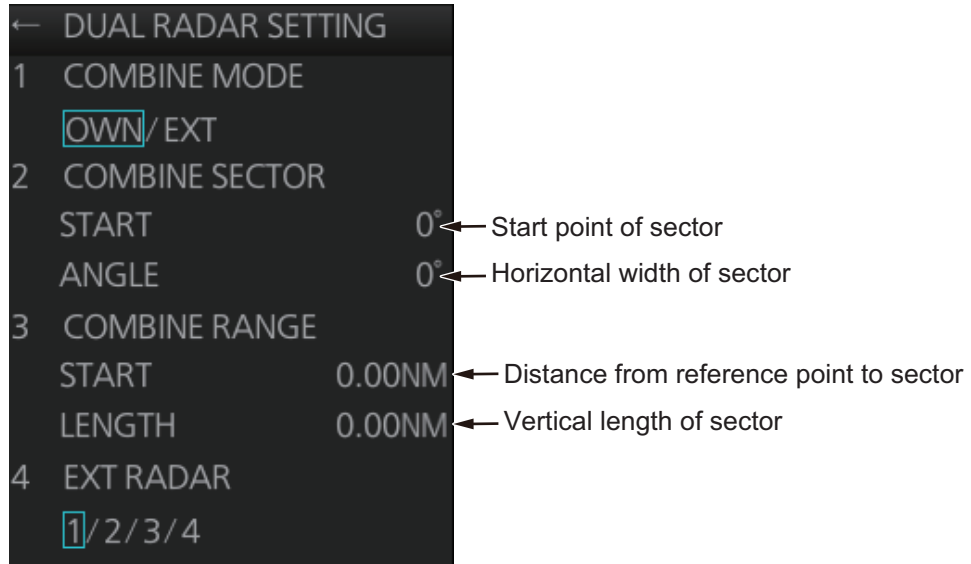

2. Select [1 COMBINE MODE] to select which radar to set as reference point.
3. Select [OWN] or [EXT] as appropriate.
  - [OWN]:** Set own radar's antenna as the reference point and set display area of own radar. The area outside that set here is where the image from the external radar is displayed.
  - [EXT]:** Set the external radar's antenna as the reference point and set the display area of the external radar. The area outside that set here is where the image from own radar is displayed.

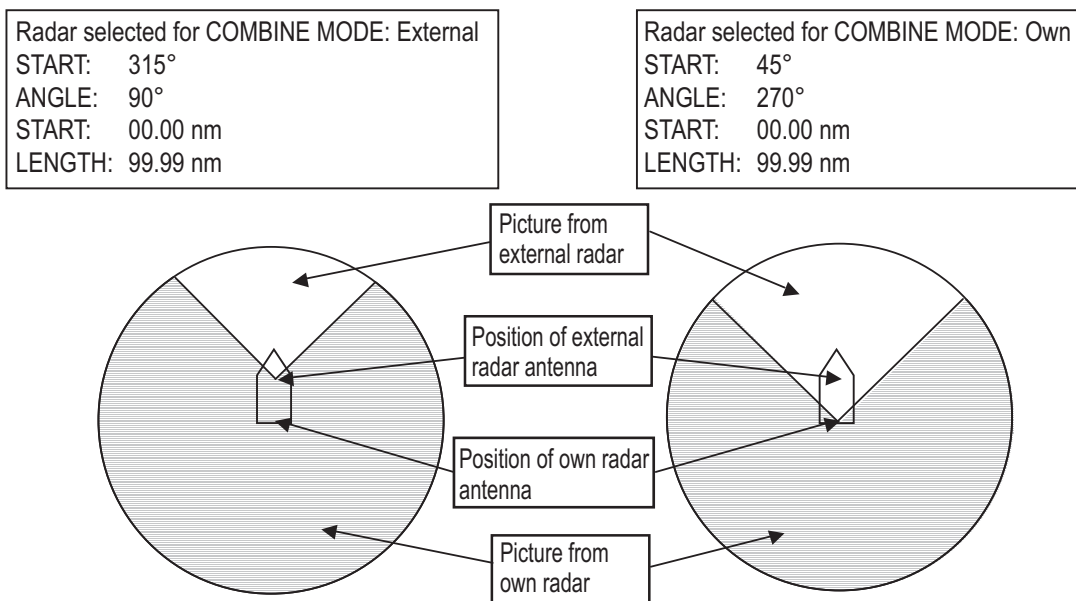

4. Select [2 COMBINE SECTOR] to set the width of the sector.

5. Use the scrollwheel to set [START] and [ANGLE], referring to the example below. Spin the scrollwheel to set and push it to confirm. A solid green line marks the dual radar display area.

- **[START]**: Start point of the sector (in degrees, 000-359).
- **[ANGLE]**: Horizontal width of the sector (in degrees, 000-359).

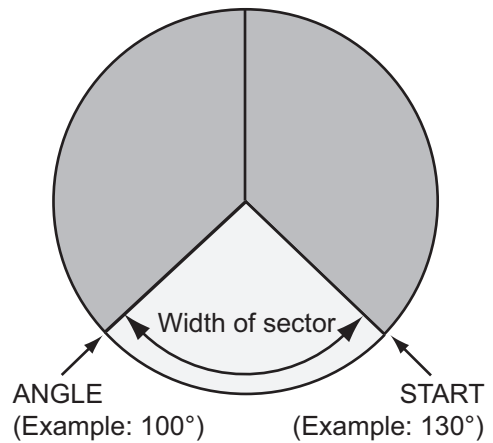

6. Select [3 COMBINE RANGE] to set the vertical width of the sector.
7. Use the scrollwheel to set [START] and [LENGTH], referring to the example below. Spin the scrollwheel to set and push it to confirm.

- **[START]**: Distance from reference point to sector
- **[LENGTH]**: Vertical length of sector

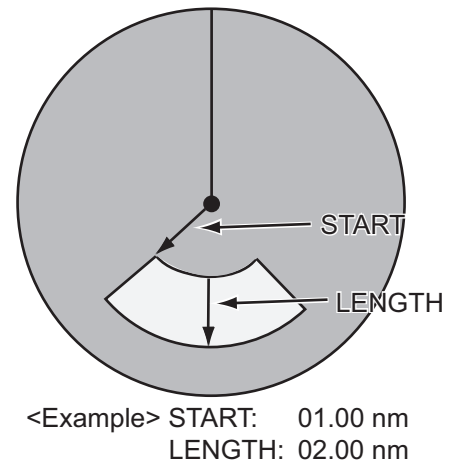

### 3.5.3 How to select the external radar (image source) to use

The dual radar display works best with two FAR-3xx0 radars. Other makes or models can be used, however performance may vary.

1. From the [RADAR INSTALLATION] menu, select [2 SCANNER], [6 DUAL RADAR SETTING].
2. Select [4 EXT RADAR].
3. Select required radar no. (Only the numbers of radar set on the [RADAR INSTALLATION] menu are valid.)
 

**Note 1:** The dual radar will not function if a radar incompatible to the dual radar function is selected.

**Note 2:** The dual radar display is designed to be used with two FAR-3xx0 series radars. Other makes or models can be used, however performance may vary.
4. Press the **MENU** key to close the menu.

## 3.6 Other Settings

This section describes the menu items not previously described.

### 3.6.1 [ECHO ADJ] menu

Open the main menu then select [9 RADAR INSTALLATION]→[1 ECHO ADJ] to open the [ECHO ADJ] menu.

#### [1 VIDEO LEVEL ADJ]

Adjust the video level manually. Set the radar as follows:

- Interference Rejector (IR): 2
- Echo Stretch (ES): OFF
- Echo Averaging (EAV): OFF
- Gain: 80
- Range: 24 NM
- Pulse Length: Long

Select [+] or [-]. Rotate the scrollwheel so that noise just disappears from the screen. The setting range is 0 to 32. After completion of the adjustment the radar goes into standby. If the noise does not disappear, switch to [-](+)] and try again.



#### [5 STC CURVE]

Use the default setting. Change the setting according to sea condition. The larger the number the greater the STC effect.

#### [8 RING SUPPRESSION]

Remove “ring” noise which appears with the waveguide-type radar. Adjust so the rings disappear at the range of 0.125 NM. The setting range is 0 to 255.

#### [9 VIDEO CONTRAST]

Select [LEGACY] for FAR-3xx0 series radar only.

**Note:** The [ADVANCE] setting is not available at this time.

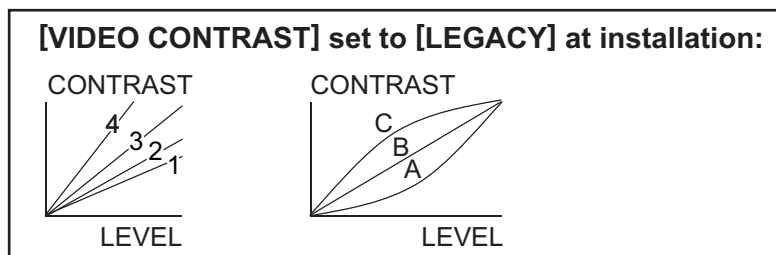

### 3.6.2 [SCANNER] menu

Open the main menu then select [9 RADAR INSTALLATION]→ [2 SCANNER] to open the [SCANNER] menu.

#### **[1 BLIND SECTOR1], [2 BLIND SECTOR2]**

Set area(s) where to prevent transmission. Heading must be properly aligned (see section 3.2) before setting any blind sector. For example, set the area where an interfering object at the rear of the antenna would produce a dead sector (area where no echoes appear) on the display. To enter an area, enter start bearing relative to the heading and dead sector angle. To erase the area, enter 0 for both the [START] and [ANGLE] sections. The setting range of [START] is 0° to 359° and [ANGLE] is 0° to 180°.

**Note:** Turn off a stern blind sector when adjusting the PM gain, to display the echo from the performance monitor properly.

#### **[3 ANT REVOLUTION]**

For HSC only. Select [LO] for 36 rpm, [HI] for 42 rpm. [AUTO] sets the normal rotation speed to 36 rpm and switches the rotation speed to 42 rpm when the short pulse is selected.

**Note:** Select [OFF] at [ANT SW] to prevent antenna rotation. [ANT STOPPED] prevents transmission while the antenna is stopped in STBY.

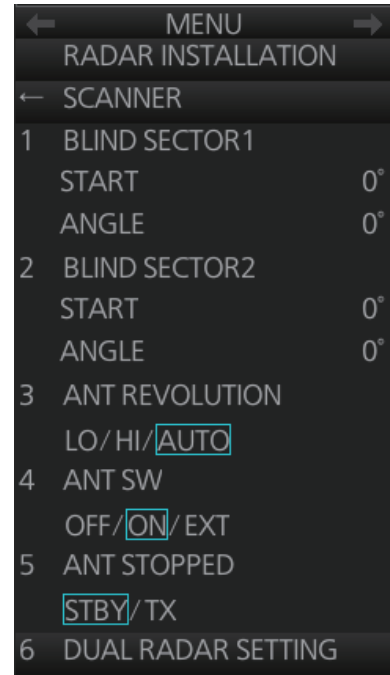

### 3. SETTINGS AND ADJUSTMENTS

#### 3.6.3 [INSTALLATION] menu

Open the main menu then select [9 RADAR INSTALLATION]→ [3 INSTALLATION] to open the [INSTALLATION] menu.

*IMO-/A-type radars*

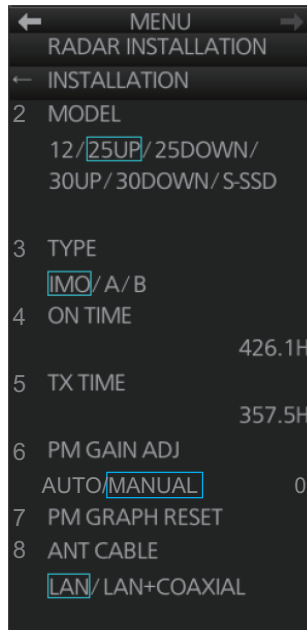

*B-type radar*

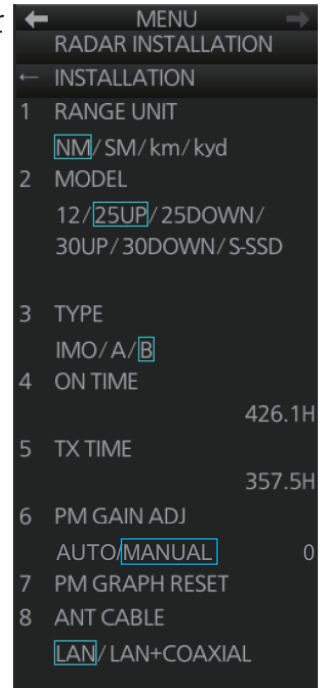

#### **[1 RANGE UNIT]**

For the **B-type radar**, select the range unit, NM, SM, KM or kyd then push the left button.

#### **[2 MODEL]**

Confirm the model of your radar. If this setting is different from your model, the radar will not function properly. The number before a diagonal (12, 25, 30) is the output power (in kW). [UP], [DOWN] indicates the location of the transceiver unit. [UP] is in the antenna unit, and [DOWN] means separate transceiver unit. [S-SSD] means S-band solid state device.

#### **[3 TYPE]**

Select the type of radar: [IMO], [A] or [B].

[IMO]: IMO specifications

[A]: Near-IMO specifications

[B]: Non-Japanese fishing vessel specifications

#### **[4 ON TIME], [5 TX TIME]**

These items show the number of hours the radar has been turned on and transmitted, respectively. Value can be changed; for example, after replacing the magnetron. [TX TIME] can be reset to 0.

**[6 PM GAIN ADJ]**

Adjust the performance monitor, automatically or manually, whenever the magnetron is replaced. For automatic adjustment, no further operation is required; close the menu at the completion of the adjustment. For manual do as follows to adjust the performance monitor gain.

1. Adjust the **GAIN** control so that a slight amount of white noise appears on the screen. Arcs for the performance monitor appear on the screen.

2. Select [PM GAIN ADJ] then spin the scrollwheel so that the outer arc faintly appears. The setting range is 0 to 255. Wait at least eight scans then right click to set.

**Note:** Turn off a stern blind sector before adjusting the PM gain, to display the echo from the performance monitor properly.

- Range: 24 NM
- Pulse Length: Long
- A/C SEA: OFF (turn off manually)
- A/C RAIN: OFF (turn off manually)
- Echo Averaging (EAV): OFF
- Video Contrast: 2-B

**[7 PM GRAPH RESET]**

Select this item to reset all PM graphs, after replacing the magnetron. The message shown below appears. Click the [OK] button to reset the PM graphs.

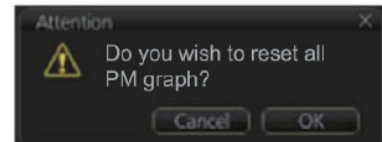

**[8 ANT CABLE]**

Select the method of connection between the radar sensor and the processor unit. [LAN] (LAN cable only) or [LAN+COAXIAL] (LAN and coaxial cables). Select [LAN+COAXIAL] when the optional LAN Signal Converter is installed.

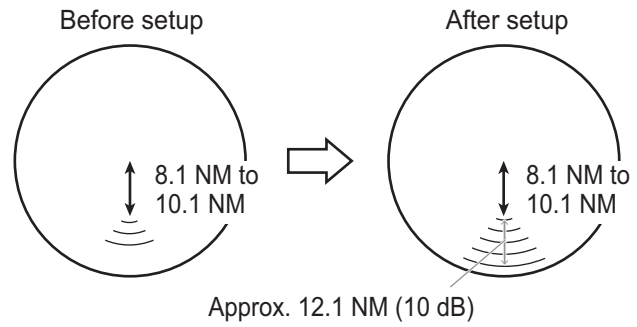

Ex: When [ARC] is set to [5]  
 (The location of arcs changes with the setting of [ARC] in [PERFORMANCE MON] in the [ECHO] menu.)

### 3.6.4 [TT PRESET] menu

Open the main menu then select [9 RADAR INSTALLATION]→ [4 TT PRESET] to open the [TT PRESET] menu.

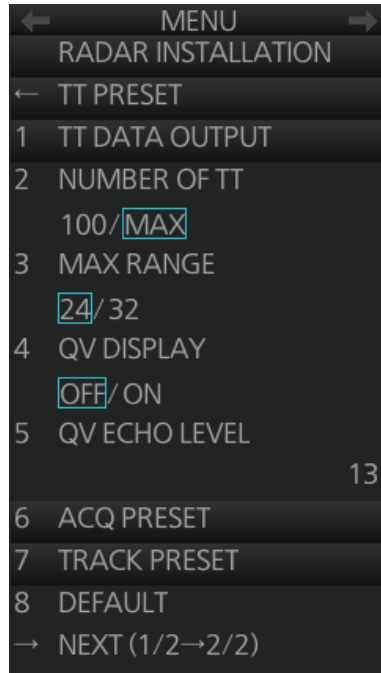

Page 1

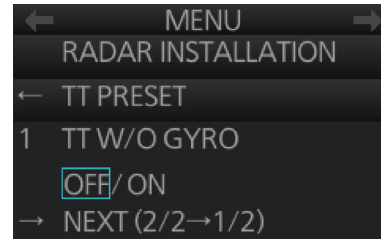

Page 2

#### [1 TT DATA OUTPUT]

Show the [TT DATA OUTPUT] menu.

**Note:** Confirm the data input configuration for the equipment which will receive the TT (target tracking) sentence BEFORE setting this menu.

- [SELECT SENTENCE]: Select the sentence that is output the TT target data.  
 [OFF]: For no output of the TT data.  
 [TTM]: For connected equipment which can receive the TTM sentence.  
 [TTD]: For connected equipment which can receive the TTD sentence.  
 [BOTH]: For connected equipment which can receive both TTM and TTD sentences.

**Note:** This setting is valid for LAN connection only. For serial connection, the output sentence is determined on the [Common Installation Setting] menu, this setting is invalid. See WEB SETTING MANUAL (E32-01305) for details. For both LAN and serial connections, set the baudrate to 38,400 bps.

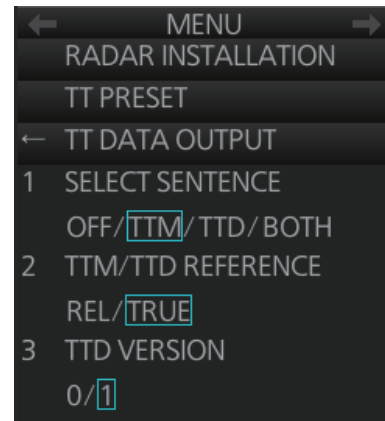

- [TTM/TTD REFERENCE]: Set the output format for tracked target's bearing.  
 [REL] (Target bearing from own ship, degree relative, target course, degree relative), or [TRUE] (Target bearing, degree true, target course, degree true).
- [TTD VERSION]: For TTD sentence, select the required protocol version for the connected equipment for TTD output ([0]: ver. 0 only, [1]: ver. 0 and ver. 1).  
**Note:** If the connected equipment is FMD-3x00, select [1].



**[2 NUMBER OF TT]**

Set the number of targets that can be acquired, [100] or [MAX] (200). For FAR-2xx7 radar, select [100].

**[3 MAX RANGE]**

Select the maximum target tracking range, 24 or 32 nm.

**[4 QV DISPLAY]**

[OFF]: Normal picture,

[ON]: Quantized video. The normal picture is in effect whenever the power is turned on regardless of this setting.

**[5 QV ECHO LEVEL]**

Set the detection level of echoes. The setting range is 1 to 31.

**[6 ACQ PRESET]**

Show the [ACQ PRESET] menu.

- [LAND SIZE]: Set the land size in units of 100 m. The setting range is 100 to 3000 m. A target whose length is equal to or greater than the length set here is judged as a land target.
- [ANT SELECT]: Set the antenna radiator type of your radar. The size of the echo changes with radiator size. Select the correct radiator type to ensure proper performance.
- [AUTO ACQ CORRE]: Set the correlation count of automatic acquisition. The setting range is 3 to 10.
- [AUTO ACQ WEED]: Set the cancel count of automatic acquisition. The setting range is 1 to 5.

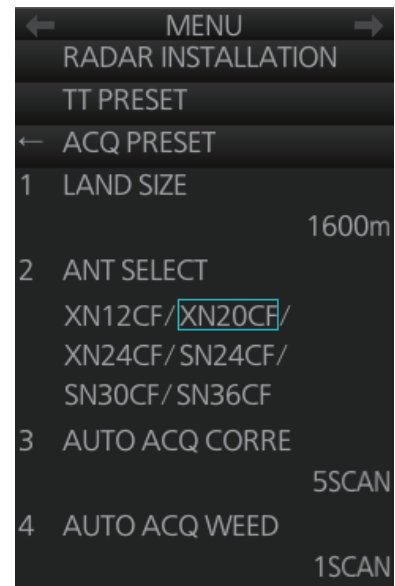

### 3. SETTINGS AND ADJUSTMENTS

#### **[7 TRACK PRESET]**

- **[GATE SIZE]:** Set the gate size among [S], [M], [L] or [LL].
- **[FILTER RESPONSE]:** Set the filter response function. The setting range is 1 to 4.  
1: Filter response is improved.  
4: Filter stability is improved.
- **[LOST COUNT]:** Set the number of scans to allow before a target is declared a lost target. The setting range is 1 to 20.
- **[MAX SPEED]:** No use.
- **[START TIME TGT VECT]:** Set the number of seconds or number of scans to wait before showing the vector for a newly acquired target. Select [TIME] or [SCAN] then enter value.



#### **[8 DEFAULT]**

Restore the default settings for the [RADAR INSTALLATION] menu settings.

#### **[1 TT W/O GYRO] (page 2)**

TT can be used without a gyro. Select [ON] to use TT without a gyro.

### 3.6.5 [OTHERS] menu

Open the main menu then select [9 RADAR INSTALLATION] → [5 OTHERS] to open the [OTHERS] menu.

#### **[1 DEMO ECHO]**

Select the type of demonstration echo to use. [EG] (Echo Generator), [TT-TEST] or [PC]. Select [OFF] to deactivate the demonstration echo feature.

#### **[2 EAV W/O GYRO]**

The each averaging feature can be used without a gyrocompass. Select [ON] to use the feature without a gyrocompass.

#### **[3 TT FUNC]**

Activate or deactivate the TT function.

#### **[4 SUB OUTPUT]**

No use.

#### **[5 COMBINE FUNC]**

Enables, disables the dual radar display. Select [ON] to enable the dual radar display.

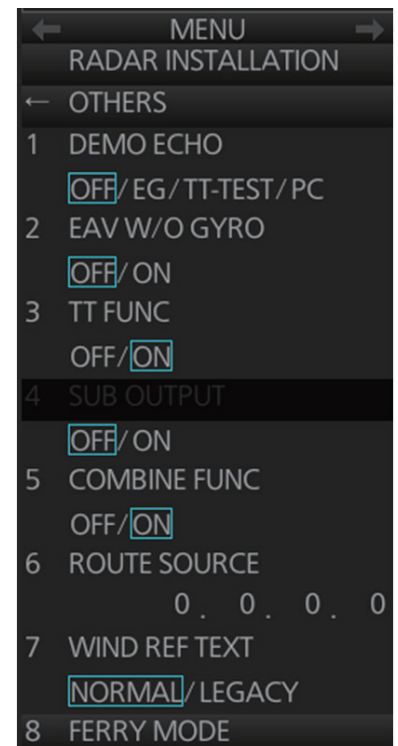

**[6 ROUTE SOURCE]**

Set the IP address when receiving route information from a route source other than FMD-3200/3300.

**[7 WIND REF TEXT]**

Select the format of the wind information on the [NAV data] box. For the wind reference, set on the [WIND STB] (Main menu→[4 INFORMATION BOX]→[2 SET NAV DATA]→[6 WIND STB]) menu.

**[8 FERRY MODE]**

Select the direction in which the antenna was installed (oriented) at [ANTENNA DIRECTION].

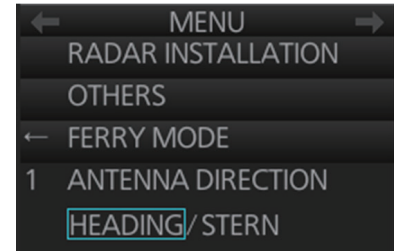

## 3.7 Network Transmission Setting Between ECDIS and Radar

Connect the ECDIS and FAR-3xx0 series radar with the LAN cable to show the radar echo and TT symbols on the ECDIS chart display, and show the ECDIS route and user chart symbols on the radar display.

1. Press the **MENU** key five times while holding down the [1 HL OFF] key.
2. Select [9 RADAR INSTALLATION]→[4 TT PRESET]→[1 TTM/TTD PREFERENCE] and then select [TRUE].
3. On the ECDIS, open the [Common Installation Setting] menu.
4. Open the [Own Ship Setting] menu on the ECDIS to select [Radar Antenna] on the menu bar.
5. For one antenna unit, check [RAS001]. For two antenna units, check [RAS001] and [RAS002].

## 3.8 How to Set the Forwarding Distance

Set the forwarding distance\* as follows. The configuration can be copied to other units connected to the network after saving the configuration.

\*: The distance the ship travels straight after the steering control.

1. In the chart mode, press **Ctrl**, **Shift** and **t** keys simultaneously on the control unit or keyboard. A dialog box for password input appears.

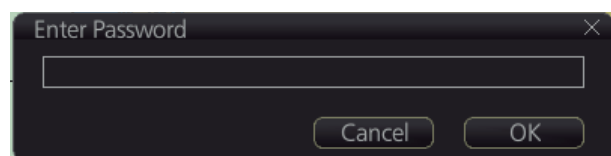

### 3. SETTINGS AND ADJUSTMENTS

2. Enter the password and click the [OK] button.  
**Note:** The edit mode remains enabled until you press **Ctrl**, **Shift** and **t** keys simultaneously or reboot the unit.
3. Click [MENU] in the chart mode to open the menu.
4. Click [Navigation Parameter] to show the [Navigation Parameter] setting window.



5. Enter [SPD kn] (ship speed), [Radius NM] (turning radius) and [FWD DIST NM] (forwarding distance\*).
6. When [FWD DIST NM] is different between port and starboard sides, check the checkbox of [Use different values for Port and Starboard] and then enter each setting value.



7. Click the [Save] button to save the configuration.

## 3.9 Synchronization With Ship's Clock

The time (UTC) received from the GPS is shown. If the ZDA sentence is input from the ship's clock, the time synchronized with the ship's clock can be shown.

Do as follows to activate the synchronization with the ship's clock.

**Note:** The local time setting is not available when the synchronization with ship's clock is active.

1. In the chart mode, press **Ctrl**, **Shift** and **t** keys simultaneously on the control unit or keyboard. A dialog box for entry of password appears.
2. Enter the password and click the [OK] button.  
**Note:** The edit mode remains enabled until you press **Ctrl**, **Shift** and **t** keys simultaneously or reboot the unit.
3. Click [MENU] to open the menu.

- Click [Ship & Route Parameters], then click the [Function1] tab.

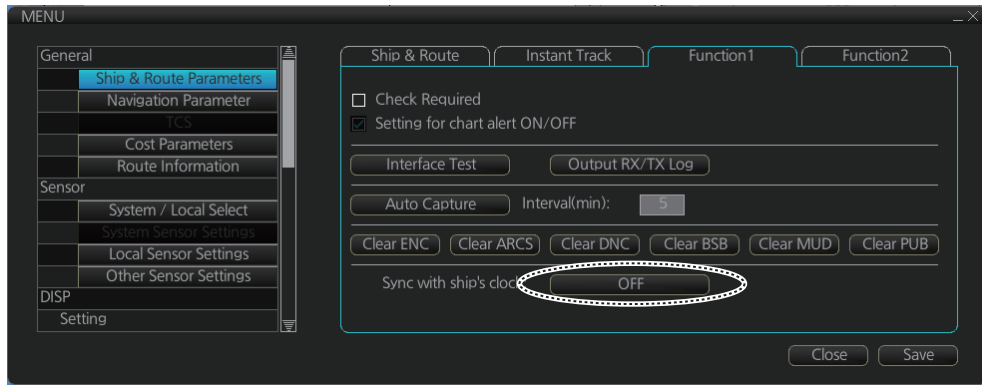

- Click the [OFF] button of [Sync with ship's clock] to set "ON".
- Click the [Save] button to save the configuration.

### 3.10 How to Change the Display Color for Sensor Data Based on Integrity

The following procedure shows how to change the color of the data in the sensor information box based on the results of the Integrity Check. For the Integrity Check, see the Operator's Manual for the Chart Radar.

- In the chart mode, press **Ctrl**, **Shift** and **t** keys simultaneously on the control unit or keyboard. A dialog box for entry of password appears.
- Enter the password and click the [OK] button.  
**Note:** The edit mode remains enabled until you press **Ctrl**, **Shift** and **t** keys simultaneously or reboot the unit.
- Click [MENU] to open the menu.
- Click [Ship & Route Parameters], then click the [Function2] tab.

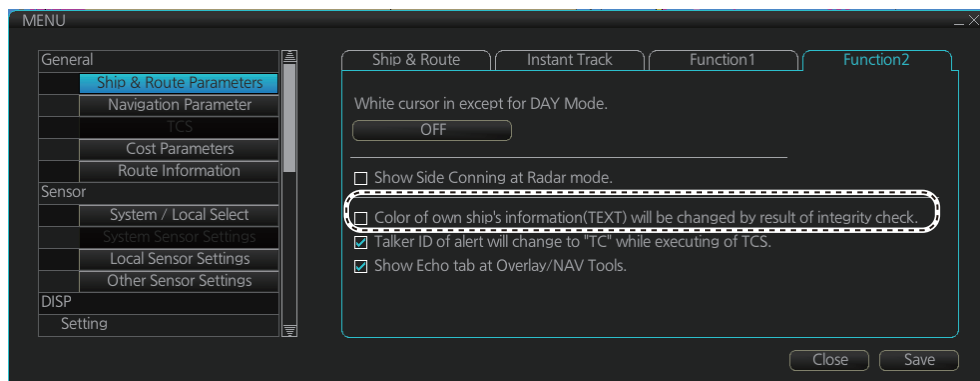

- Check the checkbox of [Color of own ship's information (TEXT) will be changed by result of integrity check].
- Click the [Save] button to save the configuration.

### 3.11 How to display the [Echo] page

To overlay the radar image on the chart mode, display the [Echo] page in the [Overlay/NAV Tools] box. For details, see the Operator's Manual for the Chart Radar.

**Note 1:** For B-type radar, the [Echo] page is not available regardless of this setting.

**Note 2:** In radar mode, set the radar to transmit to show the radar image on the chart mode.

1. In the chart mode, press **Ctrl**, **Shift** and **t** keys simultaneously on the control unit or keyboard. A dialog box for entry of password appears.
2. Enter the password and click the [OK] button.  
**Note:** The edit mode remains enabled until you press **Ctrl**, **Shift** and **t** keys simultaneously or reboot the unit.
3. Click [MENU] to open the menu.
4. Click [Ship & Route Parameters], then click the [Function2] tab.

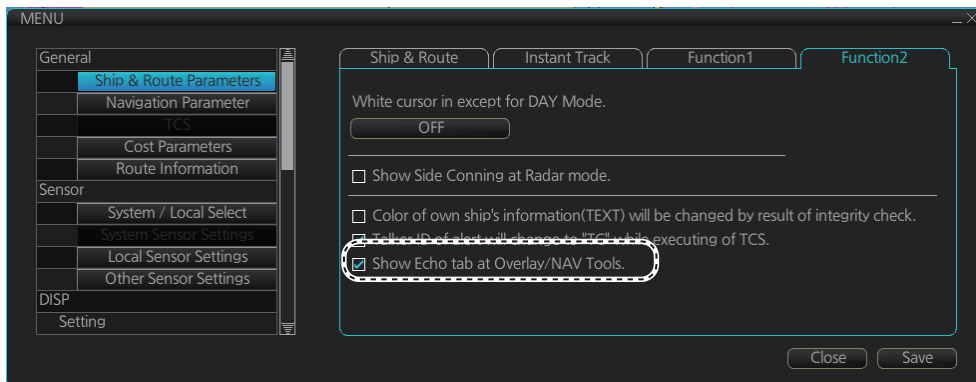

5. Check the checkbox of [Show Echo tab at Overlay/NAV Tools].
6. Click the [Save] button to save the configuration.

### 3.12 Web Setting Menu

Set up the radar from the [Common Installation Setting] menu on the web browser. For details on the [Common Installation Setting] menu, see the Instruction Manual (E32-01305).

## 4. INPUT/OUTPUT DATA

### NOTICE

The radar(s) must be interconnected to the following type approved sensors:

- EPFS meeting the requirements of the IMO resolution MSC.112(73).
- Gyrocompass meeting the requirements of the IMO resolution A.424(XI).
- SDME meeting the requirements of IMO resolution MSC.96(72).

The radar may be interconnected via HUB-3000 to other FURUNO processing units having approved LAN ports.

### 4.1 Processor Unit

Input and output data are shown in the table below.

#### Input

Data	Specification	Contents	Remarks
Heading signal	IEC 61162-2*		
Speed signal	IEC 61162-1 Ed.4		
Navaid data	IEC 61162-1 Ed.4	Position, time and date, datum, course, speed, wind, current, depth, temperature, Navtex, etc.	
AIS signal	IEC 61162-2		
Alarm handling signal	Contact closure		Input from alarm system
	IEC 61162-1 Ed.4		Input from alarm system

\*: Data input cycle must be more than 40 Hz (high speed craft) or 20 Hz (conventional ships).

#### Output

Data	Specification	Contents	Remarks
Radar system data	IEC 61162-1 Ed.4	RSD, OSD	
TT data**	IEC 61162-1 Ed.4	TTD, TTM, TLB	
Alarm signal	IEC 61162-1 Ed.4		4 systems, output contents are selected by menu.
	Contact closure		

\*\* : The output sentence and baud rate can be set at the PC (See the Instruction Manual). The mode can be set at the [TT PRESET] menu (See paragraph 3.6.4).

## 4.2 IEC 61162 Sentences

### Input sentence and sentence priority

Data	Sentence priority
Acknowledge alarm	ACK
AIS base station addressed channel management command	ACM
AIS addressed and binary broadcast acknowledgment	ABK
AIS voyage static data	VSD
Datum	DTM
Depth	DPT>DBT
Heartbeat supervision report	HBT
Heading (true)	THS>HDT
NAVTEX received message	NRX
Position	GNS>GGA>RMC>GLL
Set alarm state	ALR
Set and drift	CUR>VDR
Route transfer report	RRT
Speed (position)	VTG>RMC
Speed (SOG)	VBW
Speed (STW)	VBW>VHW
Time and date	ZDA
UAIS VHF data-link message	VDM
UAIS VHF data-link own-vessel report	VDO
Water temperature	MTW
Wind speed and angle (relative)	MWV (R)
Wind speed and angle (true)	MWV (T)

### Output sentences

Data	Sentence
Cyclic alert list	ALC
Alert sentence	ALF
Alert command refused	ARC
Acknowledge alarm	ACK
Addressed binary and safety related message	ABM
AIS broadcast binary message	BBM
General event message	EVE
Heartbeat supervision report	HBT
Own ship data	OSD
Route transfer report	RRT
Radar system data	RSD
Set alarm state	ALR
TT target data	TTD, TLB, TTM
Voyage static data	VSD



# APPENDIX 1 JIS CABLE GUIDE

Cables listed in the manual are usually shown as Japanese Industrial Standard (JIS). Use the following guide to locate an equivalent cable locally.

JIS cable names may have up to 6 alphabetical characters, followed by a dash and a numerical value (example: DPYC-2.5).

For core types D and T, the numerical designation indicates the *cross-sectional Area (mm<sup>2</sup>)* of the core wire(s) in the cable.

For core types M and TT, the numerical designation indicates the *number of core wires* in the cable.

## 1. Core Type

D: Double core power line

T: Triple core power line

M: Multi core

TT: Twisted pair communications  
(1Q=quad cable)

## 2. Insulation Type

P: Ethylene Propylene  
Rubber

## 3. Sheath Type

Y: PVC (Vinyl)

## 4. Armor Type

C: Steel

## 5. Sheath Type

Y: Anticorrosive vinyl  
sheath

## 6. Shielding Type

S: All cores in one sheath

-S: Individually sheathed cores

SLA: All cores in one shield, plastic  
tape w/aluminum tape

-SLA: Individually shielded cores,  
plastic tape w/aluminum tape



DPYCY



TPYCY

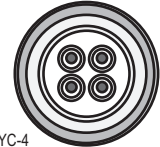

MPYC-4

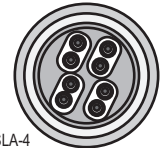

TTYCSLA-4

1 2 3 4 5 6  
EX: TTYCYSLA - 4  
Designation type # of twisted pairs

1 2 3 4  
MPYC - 4  
Designation type # of cores

The following reference table lists gives the measurements of JIS cables commonly used with Furuno products:

Type	Core Area	Core Diameter	Cable Diameter	Type	Core Area	Core Diameter	Cable Diameter
DPYC-1.5	1.5mm <sup>2</sup>	1.56mm	11.7mm	TTYCS-1	0.75mm <sup>2</sup>	1.11mm	10.1mm
DPYC-2.5	2.5mm <sup>2</sup>	2.01mm	12.8mm	TTYCS-1T	0.75mm <sup>2</sup>	1.11mm	10.6mm
DPYC-4	4.0mm <sup>2</sup>	2.55mm	13.9mm	TTYCS-1Q	0.75mm <sup>2</sup>	1.11mm	11.3mm
DPYC-6	6.0mm <sup>2</sup>	3.12mm	15.2mm	TTYCS-4	0.75mm <sup>2</sup>	1.11mm	16.3mm
DPYC-10	10.0mm <sup>2</sup>	4.05mm	17.1mm	TTYCSLA-1	0.75mm <sup>2</sup>	1.11mm	9.4mm
DPYCY-1.5	1.5mm <sup>2</sup>	1.56mm	13.7mm	TTYCSLA-1T	0.75mm <sup>2</sup>	1.11mm	10.1mm
DPYCY-2.5	2.5mm <sup>2</sup>	2.01mm	14.8mm	TTYCSLA-1Q	0.75mm <sup>2</sup>	1.11mm	10.8mm
DPYCY-4	4.0mm <sup>2</sup>	2.55mm	15.9mm	TTYCSLA-4	0.75mm <sup>2</sup>	1.11mm	15.7mm
MPYC-2	1.0mm <sup>2</sup>	1.29mm	10.0mm	TTYCY-1	0.75mm <sup>2</sup>	1.11mm	11.0mm
MPYC-4	1.0mm <sup>2</sup>	1.29mm	11.2mm	TTYCY-1T	0.75mm <sup>2</sup>	1.11mm	11.7mm
MPYCSLA-4	1.0mm <sup>2</sup>	1.29mm	11.4mm	TTYCY-1Q	0.75mm <sup>2</sup>	1.11mm	12.6mm
MPYC-7	1.0mm <sup>2</sup>	1.29mm	13.2mm	TTYCY-4	0.75mm <sup>2</sup>	1.11mm	17.7mm
MPYC-12	1.0mm <sup>2</sup>	1.29mm	16.8mm	TTYCY-4S	0.75mm <sup>2</sup>	1.11mm	21.1mm
TPYC-1.5	1.5mm <sup>2</sup>	1.56mm	12.5mm	TTYCY-4SLA	0.75mm <sup>2</sup>	1.11mm	19.5mm
TPYC-2.5	2.5mm <sup>2</sup>	2.01mm	13.5mm	TTYCYS-1	0.75mm <sup>2</sup>	1.11mm	12.1mm
TPYC-4	4.0mm <sup>2</sup>	2.55mm	14.7mm	TTYCYS-4	0.75mm <sup>2</sup>	1.11mm	18.5mm
TPYCY-1.5	1.5mm <sup>2</sup>	1.56mm	14.5mm	TTYCYSLA-1	0.75mm <sup>2</sup>	1.11mm	11.2mm
TPYCY-2.5	2.5mm <sup>2</sup>	2.01mm	15.5mm	TTYCYSLA-4	0.75mm <sup>2</sup>	1.11mm	17.9mm
TPYCY-4	4.0mm <sup>2</sup>	2.55mm	16.9mm				

# APPENDIX 2 ROD TERMINALS

MC-3000S, MC-CS Board (24P0114)

Connector #	Pin #	Signal name	Rod terminal to use	Connected cable
J1	1	24V_VOUT	AI 0.34-6 TQ (blue)	MC1.5-W-Lxxx
	2	24V_GND		
	3	MODBUS-A	AI 0.14-8 GY (gray)	
	4	MODBUS-B		
	5	GND		

Connector #	Pin #	Signal name	Rod terminal to use	Connected cable
J2	1	24V_IN	AI 1.5-6 BK (black)	DPYC-1.5
	2	24V_GND		
	3	PWR_FAIL-A	AI 0.75-6 GY (Gray)	TTYCS-4 TTYCSLA-4
	4	PWR_FAIL-COM		
	5	PWR_FAIL-B		
	6	NC	-	-

Connector #	Pin #	Signal name	Rod terminal to use	Connected cable
J4	1	TD1-A	AI 0.75-6 GY (Gray)	TTYCS-4 TTYCSLA-4
	2	TD1-B		
	3	RD1-A		
	4	RD1-B		
	5	ISOGND1		
	6	RD1-H		
	7	RD1-C		

Connector #	Pin #	Signal name	Rod terminal to use	Connected cable
J5	1	TD2-A	AI 0.75-6 GY (gray)	TTYCS-4 TTYCSLA-4
	2	TD2-B		
	3	RD2-A		
	4	RD2-B		
	5	ISOGND2		
	6	RD2-H		
	7	RD2-C		

Connector #	Pin #	Signal name	Rod terminal to use	Connected cable
J6	1	TD3-A	AI 0.75-6 GY (gray)	TTYCS-4 TTYCSLA-4
	2	TD3-B		
	3	RD3-A		
	4	RD3-B		
	5	ISOGND3		
	6	RD3-H		
	7	RD3-C		

Connector #	Pin #	Signal name	Rod terminal to use	Connected cable
J7	1	TD4-A	AI 0.75-6 GY (gray)	TTYCS-4 TTYCSLA-4
	2	TD4-B		
	3	RD4-A		
	4	RD4-B		
	5	ISOGND4		
	6	RD4-H		
	7	RD4-C		
Connector #	Pin #	Signal name	Rod terminal to use	Connected cable
J8	1	TD5-A	AI 0.75-6 GY (gray)	TTYCS-1Q TTYCSLA-1Q
	2	TD5-B		
	3	RD5-H		
	4	RD5-C		
	5	TD6-A		TTYCS-1Q TTYCSLA-1Q
	6	TD6-B		
	7	RD6-H		
	8	RD6-C		
Connector #	Pin #	Signal name	Rod terminal to use	Connected cable
J9	1	TD7-A	AI 0.75-6 GY (gray)	TTYCS-1Q TTYCSLA-1Q
	2	TD7-B		
	3	RD7-H		
	4	RD7-C		
	5	TD8-A		TTYCS-1Q TTYCSLA-1Q
	6	TD8-B		
	7	RD8-H		
	8	RD8-C		

MC-3010A MC-ANLG Board (24P0115)

Connector #	Pin #	Signal name	Rod terminal to use	Connected cable
J1	1	24V_IN	AI 0.34-6 TQ (blue)	MC1.5-W-Lxxx
	2	24V_GND		
	3	MODBUS-A	AI 0.14-8 GY (gray)	
	4	MODBUS-B		
	5	GND		
Connector #	Pin #	Signal name	Rod terminal to use	Connected cable
J2	1	24V_OUT	AI 0.34-6 TQ (blue)	MC1.5-W-Lxxx
	2	24V_GND	AI 0.14-8 GY (gray)	
	3	MODBUS-A		
	4	MODBUS-B		
	5	GND		
Connector #	Pin #	Signal name	Rod terminal to use	Connected cable
J3*	1	AN1_IN	AI 0.75-6 GY (gray)	TTYCS-1 TTYCSLA-1
	2	AN1_GND		
	3	CURR1_JP1		
	4	CURR1_JP2		
Connector #	Pin #	Signal name	Rod terminal to use	Connected cable
J4*	1	AN2_IN	AI 0.75-6 GY (gray)	TTYCS-1 TTYCSLA-1
	2	AN2_GND		
	3	CURR2_JP1		
	4	CURR2_JP2		
Connector #	Pin #	Signal name	Rod terminal to use	Connected cable
J5*	1	AN3_IN	AI 0.75-6 GY (gray)	TTYCS-1 TTYCSLA-1
	2	AN3_GND		
	3	CURR3_JP1		
	4	CURR3_JP2		

\*: For pin #3 and 4, no cable is connected. However the jumper connection is necessary depending on the input specification.

MC-3020D, MC-DIN Board (24P0116)

Connector #	Pin #	Signal name	Rod terminal to use	Connected cable
J1	1	24V_IN	AI 0.34-6 TQ (blue)	MC1.5-W-Lxxx
	2	24V_GND		
	3	MODBUS-A	AI 0.14-8 GY (gray)	
	4	MODBUS-B		
	5	GND		
Connector #	Pin #	Signal name	Rod terminal to use	Connected cable
J2	1	24V_OUT	AI 0.34-6 TQ (blue)	MC1.5-W-Lxxx
	2	24V_GND	AI 0.14-8 GY (gray)	
	3	MODBUS-A		
	4	MODBUS-B		
	5	GND		

Connector #	Pin #	Signal name	Rod terminal to use	Connected cable
J3*	1	DV12V_OUT1	AI 1-6 RD (red)	MPYC-12
	2	DIGI_IN1		
	3	DIGI_RTN1		
	4	GND		
	5	DC12V_OUT2		
	6	DIGI_IN2		
	7	DIGI_RTN2		
	8	GND		
Connector #	Pin #	Signal name	Rod terminal to use	Connected cable
J4*	1	DV12V_OUT3	AI 1-6 RD (red)	MPYC-12
	2	DIGI_IN3		
	3	DIGI_RTN3		
	4	GND		
	5	DC12V_OUT4		
	6	DIGI_IN4		
	7	DIGI_RTN4		
	8	GND		
Connector #	Pin #	Signal name	Rod terminal to use	Connected cable
J5*	1	DV12V_OUT5	AI 1-6 RD (red)	MPYC-12
	2	DIGI_IN5		
	3	DIGI_RTN5		
	4	GND		
	5	DC12V_OUT6		
	6	DIGI_IN6		
	7	DIGI_RTN6		
	8	GND		
Connector #	Pin #	Signal name	Rod terminal to use	Connected cable
J6*	1	DV12V_OUT7	AI 1-6 RD (red)	MPYC-12
	2	DIGI_IN7		
	3	DIGI_RTN7		
	4	GND		
	5	DC12V_OUT8		
	6	DIGI_IN8		
	7	DIGI_RTN8		
	8	GND		

\*: Pin #1 and 5: no cable connection. However the jumper connection is necessary between #1 and 2 and #5 and 6 depending on the input specification.

APPENDIX 2 ROD TERMINALS

MC-3030D, MC-DOUT Board (24P0117)

Connector #	Pin #	Signal name	Rod terminal to use	Connected cable
J1	1	24V_IN	AI 0.34-6 TQ (blue)	MC1.5-W-Lxxx
	2	24V_GND		
	3	MODBUS-A	AI 0.14-8 GY (gray)	
	4	MODBUS-B		
	5	GND		
Connector #	Pin #	Signal name	Rod terminal to use	Connected cable
J2	1	24V_OUT	AI 0.34-6 TQ (blue)	MC1.5-W-Lxxx
	2	24V_GND		
	3	MODBUS-A	AI 0.14-8 GY (gray)	
	4	MODBUS-B		
	5	GND		
Connector #	Pin #	Signal name	Rod terminal to use	Connected cable
J3	1	A1	AI 1-6 RD (red)	MPYC-12
	2	COM1		
	3	B1		
	4	A2		
	5	COM2		
	6	B2		
Connector #	Pin #	Signal name	Rod terminal to use	Connected cable
J4	1	A3	AI 1-6 RD (red)	MPYC-12
	2	COM3		
	3	B3		
	4	A4		
	5	COM4		
	6	B4		
Connector #	Pin #	Signal name	Rod terminal to use	Connected cable
J5	1	A5	AI 1-6 RD (red)	MPYC-12
	2	COM5		
	3	B5		
	4	A6		
	5	COM6		
	6	B6		
Connector #	Pin #	Signal name	Rod terminal to use	Connected cable
J6	1	A7	AI 1-6 RD (red)	MPYC-12
	2	COM7		
	3	B7		
	4	A8		
	5	COM8		
	6	B8		

# APPENDIX 3 DIGITAL INTERFACE

## Digital Interface

### Input sentence

ABK, ACK, ACM, ACN, ALR, CUR, DBT, DPT, DTM, GGA, GLL, GNS, HBT, HDT, MTW, MWV, NRX, RMC, RRT, THS, VBW, VDM, VDO, VDR, VHW, VSD, VTG, ZDA

### Output sentences

ABM, ACK, ALC, ALF, ARC, BBM, EVE, HBT, OSD, RRT, RSD, TLB, TTM, VSD

### Data reception

Data is received in serial asynchronous form in accordance with the standard referenced in IEC 61162-2 or IEC 61162-1 Ed.4.

The following parameters are used:

Baud rate: 38,400 bps (HDT, THS, !AIVDM, !AIVDO, !AIABK, \$AIALR). The baud rate of all other sentences is 4800 bps

Data bits: 8 (D7 = 0), Parity: none, Stop bits: 1

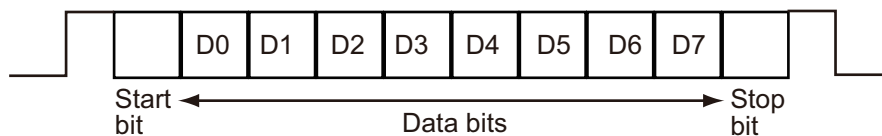

## Data Sentences

### Input sentences

ABK - UAIS Addressed and binary broadcast acknowledgment

`$**ABK,xxxxxxxx,x,x.x,x,x,*hh<CR><LF>`  
1 2 3 4 5

1. MMSI of the addressed AIS unit (9 digits)
2. AIS channel of reception (No use)
3. Message ID (6, 8, 12, 14)
4. Message sequence number (0 - 9)
5. Type of acknowledgement (See below)
  - 1 = message was broadcast (6 or 12), but not ACK by addressed AIS unit
  - 2 = message could not be broadcast (quantity of encapsulated data exceeds five slots)
  - 3 = requested broadcast of message (8, 14 or 15) has been successfully completed
  - 4 = late reception of message (7 or 13) ACK that was addressed to this AIS unit (own ship and referenced a valid transaction)
  - 5 = message has been read and acknowledged on a display unit.

ACK - Acknowledge alarm

`$**ACK,xxx,*hh<CR><LF>`  
1

1. Local alarm number (identifier) (000 - 999)

## APPENDIX 3 DIGITAL INTERFACE

### ACM, ACN - Alert command

`**ACM,hhmmss.ss,aaa,x.x,x.x,ca,a*hh<CR><LF>`

`**ACN,hhmmss.ss,aaa,x.x,x.x,ca,a*hh<CR><LF>`

1 2 3 4 5 6

1. Time (hh=00 to 23, mm=00 to 59, ss.ss=00.00 to 60.99, null)
2. Manufacturer mnemonic code (3 digit alphanumeric code, null)
3. Alert identifier (0 to 9999999)
4. Alert instance (1 to 999999, null)
5. Alert command (A=ACK from ext. equipment, Q=Request from ext. equipment, O=Responsibility transfer, S=Silence from ext. equipment)
6. Sentence status flag (C should not be null field. Sentence without C is not a command.)

#### Information about the use of ACN vs ACM

The alert command sentence formatter ACM is defined in IEC 61924-2 Ed. 1. After Ed. 1 was released, the ACM is used by other criteria and the IEC technical corrigendum adopted the sentence formatter ACN to replace the ACM. However, equipment released before the adoption of the ACN may use ACM. This equipment uses both ACN and ACM.

### ALR - Set alarm state

`**ALR,Hhmmss.ss,xxx,A,A,c—c,*hh<CR><LF>`

1 2 3 4 5

1. Time of alarm condition change, UTC (000000.00 - 235960.99)
2. Unique alarm number (identifier) at alarm source (000 - 999)
3. Alarm condition (A=threshold exceeded, V=not exceeded)
4. Alarm acknowledge state (A=acknowledged, V=not acknowledged)
5. Alarm description text (alphanumeric characters, max. 32)

### CUR - Current

`**CUR,A,x.x,x.x,x.x,x.x,a,x.x,x.x,x.x,a,a,*hh<CR><LF>`

1 2 3 4 5 6 7 8 9 10 11

1. Validity of data (A=valid, V=not valid)
2. Data set number (0 - 9)
3. Layer number (0.0 - 3.0)
4. Current depth in meters (No use)
5. Current direction in degrees (0.00 - 360.00)
6. Direction reference in use (true or relative)
7. Current speed in knots (0.00 - 99.99)
8. Reference layer depth in meters (No use)
9. Heading (0 to 360.00)
10. Heading reference in use (true or magnetic)
11. Speed reference (B=Bottom track W=Water track P=Positioning system)

### DBT - Depth below transducer

`**DBT,xxxx.x,f,xxxx.x,M,xxxx.x,F,*hh<CR><LF>`

1 2 3 4 5 6

1. Water depth (0.00-99999.99)
2. feet
3. Water depth (0.00-99999.99)
4. Meters
5. Water depth (0.00-99999.99)
6. Fathoms

### DPT - Depth

`**DPT,x.x,x.x,x.x,*hh<CR><LF>`

1 2 3

1. Water depth relative to the transducer, meters (0.00-99999.99)
2. Offset from transducer, meters (No use)
3. Minimum range scale in use (No use)



## DTM - Datum reference

```
$**DTM,ccc,a,x.x,a,x.x,a,x.x,ccc,*hh<CR><LF>
  1 2 3 4 5 6 7 8
```

1. Local datum (W84=WGS84 W72=WGS72 S85=SGS85, P90=PE90)
2. Local datum subdivision code (one character, null)
3. Lat offset, min (0 - 59.99999)
4. N/S
5. Lon offset, min (0 - 59.99999)
6. E/W
7. Altitude offset, meters (No use)
8. Reference datum (W84=WGS84 W72=WGS72 S85=SGS85, P90=PE90)

## GGA - Global positioning system fix data

```
$**GGA,hhmmss.ss,llll.lll,a,yyyy.yyy,a,x,xx,x.x,x.x,M,x.x,M,x.x,xxxx,*hh<CR><LF>
  1 2 3 4 5 6 7 8 9 10 11 12 13 14
```

1. UTC of position (no use)
2. Latitude (0000.00000 - 9000.00000)
3. N/S
4. Longitude (0000.00000 - 18000.00000)
5. E/W
6. GPS quality indicator (1 - 8)
7. Number of satellite in use (No use)
8. Horizontal dilution of precision (0.0 - 999.9)
9. Antenna altitude above/below mean sealevel (No use)
10. Unit, m (No use)
11. Geoidal separation (No use)
12. Unit, m (No use)
13. Age of differential GPS data (0 - 999)
14. Differential reference station ID (No use)

## GLL - Geographic position, latitude/longitude

```
$**GLL,llll.lll,a,yyyy.yyy,a,hhmmss.ss,a,x,*hh<CR><LF>
  1 2 3 4 5 6 7
```

1. Latitude (0000.00000 - 9000.00000)
2. N/S
3. Longitude (0000.00000 - 18000.00000)
4. E/W
5. UTC of position (No use)
6. Status (A=data valid V=data invalid)
7. Mode indicator (A=Autonomous D=Differential E=Estimated M=Manual input S=Simulator)

## GNS - GNSS fix data

```
$**GNS,hhmmss.ss,llll.lll,a,lllll.lll,a,c--c,xx,x.x,x.x,x.x,x.x,x.x,x.x,a*hh<CR><LF>
  1 2 3 4 5 6 7 8 9 10 11 12 13
```

1. UTC of position (no use)
2. Latitude (0000.00000 - 9000.00000)
3. N/S
4. Longitude (0000.00000 - 18000.00000)
5. E/W
6. Mode indicator (P, R, D, F, A, E, M, S)  
N=No fix A=Autonomous D=Differential P=Precise R=Real Time Kinematic  
F=Float RTK E=Estimated Mode M=Manual Input Mode S=Simulator Mode
7. Total number of satellites in use (No use)
8. HDOP (0.00 - 999.99)
9. Antenna altitude, meters (-999.99 - 9999.99)
10. Geoidal separation (No use)
11. Age of differential data (0 - 99)
12. Differential reference station ID (No use)
13. Navigational status indicator (S=Safe, C=Caution, U=Unsafe, V=Not valid)

## APPENDIX 3 DIGITAL INTERFACE

### HBT - Heartbeat supervision sentence

\$\*\*HBT,x.x,A,x\*hh<CR><LF>  
1 2 3

1. Configured repeat interval (00.0 to 99.9(s))
2. Equipment status (A=Normal V=System fail)
3. Sequential sequence identifier (0 to 9)

### HDT - Heading, true

\$\*\*HDT,xxx.x,T\*hh<CR><LF>  
1 2

1. Heading, degrees (0.00 to 360.00)
2. True (T)

### MTW - Water temperature

\$\*\*MTW,x.x,C<CR><LF>  
1

1. Water temperature, degrees C (-100.000 - 100.000)

### MWV - Wind speed and angle

\$\*\*MWV,x.x,a,x.x,a,A\*hh<CR><LF>  
1 2 3 4 5

1. Wind angle, degrees (0.00 - 360.00)
2. Reference (R/T)
3. Wind speed (0.00 - 9999.99)
4. Wind speed units (K=km/h M=m/s N=NM)
5. Status (A)

### NRX - NAVTEX received message

\$\*\*NRX,xxx,xxx,xx,aaax,x,hhmmss.ss,xx,xx,xxxx,x.x,x.x,A,c--c,\*hh<CR><LF>  
1 2 3 4 5 6 7 8 9 10 11 12 13

1. Number of sentences (001 to 999)
2. Sentence number (001-999)
3. Sequential message ID (00 to 99)
4. Navtex message code (aaax aa: AA to ZZ xx: 00 to 99)
5. Frequency table index (0 to 3, null)
6. UTC of receipt of message (no use)
7. Day (0 to 31, null)
8. Month (01 to 12, null)
9. Year (0000 to 9999, null)
10. Total number of characters in this series of NRX sentences (1 to 8000, null)
11. Total number of bad characters (1 to 8000, null)
12. Status indication (A/V, null)
13. Message body (English alphanumeric characters)

## RMC - Recommended minimum specific GPS/TRANSIT data

```
$GPRMC,hhmmss.ss,A,llll.ll,a,yyyy.yy,a,x.x,x.x,ddmmyy,x.x,a,a,*hh<CR><LF>
  1  2 3 4  5  6 7 8  9  10 11 12 13
```

1. UTC of position fix (000000 - 235959)
2. Status (A=data valid, V=navigation receiver warning)
3. Latitude (0000.00000 - 9000.0000)
4. N/S
5. Longitude (0000.00000 - 18000.0000)
6. E/W
7. Speed over ground, knots (0.00 - 99.94)
8. Course over ground, degrees true (0.0 - 360.0)
9. Date (010100 - 311299)
10. Magnetic variation, degrees E/W (0.00 - 180.0, null)
11. E/W
12. Mode indicator (A=Autonomous mode D=Differential mode S=Simulator  
F=Float RTK P=Precise R=Real time kinematic E=Estimated (DR) M=Manual)
13. Navigational status indication (S=Safe C=Caution U=Unsafe V=Navigational status not valid)

## RRT - Report Route Transfer

```
**RRT, a, c-c, c-c, c-c, a, a *hh <CR><LF>
  1  2  3  4  5  6
```

1. Reported transfer type.  
(M=Monitored route, A=Alternative route for editing, Q=Query for transmitting any monitored or alternative route for editing)
2. Name of transferred route. Max. 30 characters.
3. Version of transferred route. Max. 20 characters.
4. ID of current waypoint for monitored route. Max. 10 characters.
5. File transfer statuses of transferred route.  
(A=Successful reception of the route file transfer, E=Error in reception of the route file transfer)
6. Status of the intended application of the transferred route.  
(A=Content of the received route accepted and valid, V=Content of received route rejected, P=Pending, application level has not yet evaluated the received route, N=Not applicable).

## THS - True heading and status

```
**THS,xxx.x,a*hh<CR><LF>
  1  2
```

1. Heading, degrees True (0.00 to 360.00)
2. Mode indicator (A=Autonomous S=Simulator)

## VBW - Dual ground/water speed

```
**VBW,x.x,x.x,x.x,x.x,x.x,x.x,x.x,x.x,x.x,*hh<CR><LF>
  1  2  3  4  5  6  7  8  9  10
```

1. Longitudinal water speed, knots (-99.949 - 99.949)
2. Transverse water speed, knots (-99.949 - 99.949, null)
3. Status: water speed, A=data valid V=data invalid
4. Longitudinal ground speed, knots (-99.949 - 99.949)
5. Transverse ground speed, knots (-99.949 - 99.949, null)
6. Status: ground speed, A=data valid V=data invalid
7. Stern transverse water speed, knots (-99.949 - 99.949)
8. Status: stern water speed, A=data valid V=data invalid
9. Stern transverse ground speed, knots (-99.949 - 99.949)
10. Status: stern ground speed, A=data valid V=data invalid

## APPENDIX 3 DIGITAL INTERFACE

### VDM - UAIS VHF data-link message

!AIVDM,x,x,x,x,s--s,x,\*hh<CR><LF>  
1 2 3 4 5 6

1. Total number of sentences needed to transfer the message (1 to 9)
2. Message sentence number (1 to 9)
3. Sequential message identifier (0 to 9, null)
4. AIS channel Number (A or B)
5. Encapsulated ITU-R M.1371 radio message (1 - 63 bytes)
6. Number of fill-bits (0 to 5)

### VDO - UAIS VHFG data-link own vessel report

!AIVDO,x,x,x,x,s--s,x,\*hh<CR><LF>  
1 2 3 4 5 6

1. Total number of sentences needed to transfer the message (1 to 9)
2. Message sentence number (1 to 9)
3. Sequential message identifier (0 to 9, null)
4. AIS channel Number (A or B, null)
5. Encapsulated ITU-R M.1371 radio message (1 - 63 bytes)
6. Number of fill-bits (0 to 5)

### VDR - Set and drift

\$\$\*\*VDR,x,x,T,x,x,M,x,x,N,\*hh <CR><LF>  
1 2 3 4 5 6

1. Direction, degrees (0.00 - 360.00, null)
2. T=True (fixed)
3. Direction, degrees (0.00 - 360.00, null)
4. M=Magnetic (fixed)
5. Current speed (0 - 99.99)
6. N=Knots (fixed)

### VHW - Water speed and headings

\$\$\*\*VHW,x,x,T,x,x,M,x,x,N,x,x,K,\*hh <CR><LF>  
1 2 3 4 5 6 7 8

1. Heading, degrees (No use)
2. T=True (fixed, No use)
3. Heading, degrees (No use)
4. M=Magnetic (fixed, No use)
5. Speed, knots (0.00 - 99.94)
6. N=Knots (fixed)
7. Speed, knots (0.00 - 99.94)
8. K=km/hr (fixed)

### VSD- AIS voyage static data

\$--VSD,x,x,x,x,x,c--c,hhmmss.ss,xx,xx,x,x,x,\*hh<CR><LF>  
1 2 3 4 5 6 7 8 9

1. Type of ship and cargo category (0 - 255)
2. Maximum present static draught (0 to 25.5 meters, null)
3. Persons on-board (0 - 8191, null)
4. Destination (1 - 20 characters, null)
5. Estimated UTC of arrival at destination (000000.00 - 235959.99)
6. Estimated day of arrival at destination (00 to 31(UTC))
7. Estimated month of arrival at destination (00 to 12(UTC))
8. Navigational status (0 - 15, null)
9. Regional application flags (0 - 15)

**VTG - Course over ground and ground speed**

\$\*\*VTG,x.x,T,x.x,M,x.x,N,x.x,K,a,\*hh <CR><LF>  
 1 2 3 4 5 6 7 8 9

1. Course over ground, degrees (0.00 - 360.00)
2. T=True (fixed)
3. Course over ground, degrees (No use)
4. M=Magnetic (No Use)
5. Speed over ground, knots (0.00-99.94)
6. N=Knots (fixed)
7. Speed over ground (0.00-99.94)
8. K=km/h (fixed)
9. Mode indicator (A=Autonomous, D=Differential, E=Estimated (dead reckoning), M=Manual input, S=Simulator, P=Precision)

**ZDA - Time and date**

\$\*\*ZDA,hhmmss.ss,xx,xx,xxxx,xx,xx<CR><LF>  
 1 2 3 4 5 6

1. UTC (000000.00 - 235960.99)
2. Day (01 - 31)
3. Month (01 -12)
4. Year (UTC, 1970 - 2037)
5. Local zone, hours (No use)
6. Loca zone, minutes (No use)

**Output sentences**

For ACK, HBT and RRT see input sentences.

**ABM - UAIS Addressed binary and safety related message**

!\*\*ABM,x,x,x,xxxxxxxx,x,x,x,s--s,x,\*hh<CR><LF>  
 1 2 3 4 5 6 7 8

1. Total number of sentences needed to transfer the message (1 - 9)
2. Message sentence number (1 - 9)
3. Message sequence identifier (0 - 3)
4. The MMSI of destination AIS unit for the ITU-R M.1371 message (9 digits)
5. AIS channel for broadcast of the radio message (0 - 3)
6. VDL message number (6 or 12), see ITU-R M.1371
7. Encapsulated data (1 - 63 bytes)
8. Number of fill-bits (0 - 5)

**ALC - Cyclic alert list**

\$\*\*ALC,xx,xx,xx,x.x, aaa,x.x,x.x,x.x,"",\*hh<CR><LF>  
 1 2 3 4 5 6 7 8 9

1. Total number of sentences this message (01 to 99)
2. Sentence number (01 to 99)
3. Sequential message identifier (00 to 99)
4. Number of alert entries (0 to 3)
5. Manufacturer mnemonic code (FEC, null) \_\_\_\_\_
6. Alert identifier (999 or 10001 to 10999) \_\_\_\_\_
7. Alert instance (1 to 999999, null) \_\_\_\_\_
8. Revision counter (1 to 99) \_\_\_\_\_
9. Additional alert entries (see Note)

Alert entry 1  
 See Note

Note: Alert entry 0 - n: Each alert entry consists of  
 - Manufacturer Identifier (see ALF Manufactuer)  
 - Alert Identifier (see ALF Alert identifier)  
 - Alert instance (see ALF instance)  
 - Revision counter (see ALF revision counter)

Each entry identifies a certain alert with a certain state.  
 It is not allowed that an alert entry is split between two ALC sentences.

## APPENDIX 3 DIGITAL INTERFACE

### ALF - Alert sentence

```
$**ALF,x,x,x,hhmmss.ss,a,a,a,aaa,x.x,x.x,x,x,c--c,*hh<CR><LF>
  1 2 3    4    5 6 7 8 9 10 11 12 13
```

1. Total number of ALF sentences this message (1, 2)
2. Sentence number (1, 2)
3. Sequential message identifier (0 to 9)
4. Time of last change (hh=00 to 23, mm=00 to 59, ss.ss=00.00 to 60.99, null)
5. Alert category (A=Alert category A, B=Alert category B, C=Alert category C, null)
6. Alert priority (A=Alarm, W=Warning, C=Caution, null when #2 is 2)
7. Alert state (V=Not ACKed, S=Silence, A=ACKed, O/U=Resolved, Not ACKed, N=Normal state, null when #2 is 2)
8. Manufacturer mnemonic code (FEC, null)
9. Alert identifier (999 or 10001 to 10999)
10. Alert instance (1 to 999999, null)
11. Revision counter (1 to 99)
12. Escalation counter (0 to 2)
13. Alert text (max. 18 characters)

### ARC - Alert command refused

```
$**ARC,hhmmss.ss,aaa,x.x,x.x,c*hh<CR><LF>
  1      2 3 4 5
```

1. Release time of the alert command refused (hh: 00 to 23, mm: 00 to 59, ss.ss: 00.00 to 60.99)
2. Used for proprietary alerts, defined by the manufacturer (FEC, null)
3. The alert identifier (1 to 999 or 10001 to 10999)
4. The alert instance (1 to 999999, null)
5. Refused alert command (A=acknowledge, Q=request/repeat information, O=responsibility transfer, S=silence)

### BBM - UAIS broadcast binary message

```
$**BBM,x,x,x,x,xx,s--s,x,*hh<CR><LF>
  1 2 3 4 5 6 7
```

1. Total number of sentences needed to transfer the message (1 - 9)
2. Sentence number (1 - 9)
3. Sequential Message identifier (0 - 9)
4. AIS channel for broadcast of the radio message (0 - 3)
5. ITU-R M.1371 message ID (8 or 14)
6. Encapsulated data (1 - 63 bytes)
7. Number of fill-bits, 0 to 5

### EVE - General event message

```
$**EVE,hhmmss.ss,c--c,c--c*hh<CR><LF>
  1 2 3
```

1. Event time (000000.00 - 235960.99)
2. Tag code used for identification of source of event (RA0001 - RA0010, EI0001 - EI0016, IN0001 - IN0016, II0001 - II0016)
3. Event description (OPERATION)

**Note:** This sentence is output after input has been detected from either the trackball or the keyboard.

OSD- Own ship data

\$\*\*OSD,53.21,A,57.89,R,12.52,R,45.67,6.78,N\*hh<CR><LF>  
 1 2 3 4 5 6 7 8 9

1. Heading, degrees true (0.00 - 359.99, null)
2. Heading status (A=data valid, V=data invalid)
3. Vessel course, degrees true (0.00 - 359.99, null)
4. Course reference (B/M/W/R/P, null)
  - B=Bottom tracking log
  - M=Manually entered
  - W=Water referenced
  - R=Radar tracking (of fixed target)
  - P=Positioning system ground reference
5. Vessel speed (0.00 - 999.99, null)
6. Speed reference, B/M/W/R/P
7. Vessel set, degrees true, manually entered (0.00 - 359.99)
8. Vessel drift (speed), manually entered (0.00 - 99.99, null)
9. Speed units (N=Knots)

RSD - Radar system data

\$RARSD,x.x,x.x,x.x,x.x,x.x,x.x,x.x,x.x,x.x,x.x,x.x,N,H\*hh <CR><LF>  
 1 2 3 4 5 6 7 8 9 10 11 12 13

1. Origin 1 range, from own ship (0.000 - 999) (see note 2)
2. Origin 1 bearing, degrees from 0 (0.0 - 359.9) (see note 2)
3. Variable range marker 1(VRM1), range (0.000 - 999)
4. Bearing line 1(EBL1), degrees from 0 (0.0 - 359.9)
5. Origin 2 range (0.000 - 999.9) (see note 2)
6. Origin 2 bearing (0.0 - 359.9)(see note 2)
7. VRM2,.9 range (0.000 - 999)
8. EBL2, degrees (0.0 - 360.0)
9. Cursor range, from own ship (0.000 - 999)
10. Cursor bearing, degrees clockwise from 0 (0.0 - 359.9)
11. Range scale in use (0.0625 - 120)
12. Range units (K/N/S)
13. Display rotation (see note 1)

NOTES

- 1 Display rotation:
  - C=Course-up, course-over-ground up, degrees true
  - H=Head-up, ship's heading(center-line) 0 up
  - N=North-up, true north is 0 up
- 2 Origin 1 and origin 2 are located at the stated range and bearing from own ship and provide for two independent sets of variable range markers (VRM) and electronic bearing lines (EBL) originating away from own ship position.

TLB - Target label

\$\*\*TLB,x.x,c--c,x.x,c--c,...,x.x,c--c\*hh<CR><LF>  
 1 2 3 3

1. Target number "n" reported by the device (1 - 1023)
2. Label assigned to target "n" (TT=00 - 99, AIS=000000000 - 999999999)
3. Additional label pairs

## APPENDIX 3 DIGITAL INTERFACE

### TTM - Tracked target message

\$RATTM,05,12.34,23.4,R,45.67,123.4,T,1.23,8.23,N,c--c,T,R,hhmmss.ss,M\*hh<CR><LF>  
1 2 3 4 5 6 7 8 9 10 11 12 13 14 15

1. Target number (00 to 999)
2. Target distance from own ship (0.000 - 99.999)
3. Bearing from own ship,degrees (0.0 - 359.9)
4. True or Relative (T)
5. Target speed (0.00 - 999.99, null)
6. Target course, degrees (0.0 - 359.9, null)
7. True or Relative
8. Distance of closet point of approach (0.00 - 99.99, null)
9. Time to CPA, min., "-" increasing (-99.99 - 99.99, null)
10. Speed/distance units (N=NM)
11. Target name (null)
12. Target status (L=Lost Q=Acquiring T=Tracking)
13. Reference target (R, null otherwise)
14. UTC of data (null)
15. Type of acquisition (A=Automatic M=Manual )

### VSD - UAIS Voyage static data

\$--VSD,x.x,x.x,x.x,c--c,hhmmss.ss,xx,xx,x.x,x.x\*hh<CR><LF>  
1 2 3 4 5 6 7 8 9

1. Type of ship and cargo category (0 - 255)
2. Maximum present static draught (0 to 25.5 meters, null)
3. Persons on-board (0 - 8191, null)
4. Destination (1 - 20 characters, null)
5. Estimated UTC of arrival at destination (000000.00 - 235959.99)
6. Estimated day of arrival at destination (00 to 31(UTC))
7. Estimated month of arrival at destination (00 to 12(UTC))
8. Navigational status (0 - 15, null)
9. Regional application flags (0 - 15)



Serial Interface

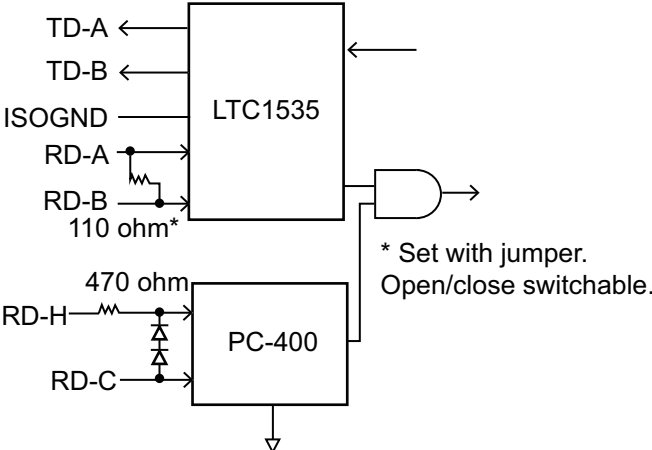

Processor Unit: IEC 61162-2/1 input/output  
Sensor Adapter: IEC 61162-2/1 input/output

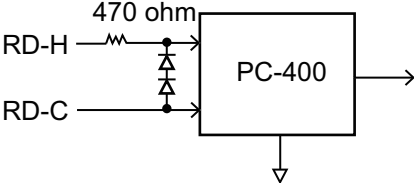

Processor Unit: IEC 61162-1 input  
Sensor Adapter: IEC 61162-1 input

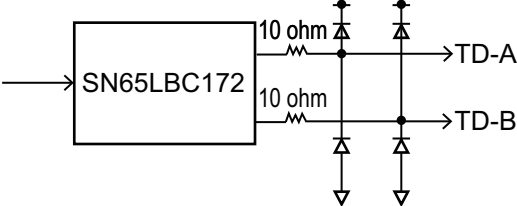







Processor Unit: IEC 61162-1 output  
Sensor Adapter: IEC 61162-1 output

# PACKING LIST

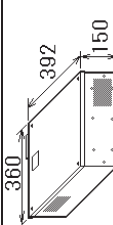
EC-3000-R3210X\*/R3220X\*/R3310X\*/R3320X\*/R32XBB/R2710\*/2720\*

03HL-X-9861-5

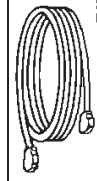
1/1

NAME	OUTLINE	DESCRIPTION/CODE No.	Q'TY
<b>ユニット</b>			
制御部		EC-3000-*	1
PROCESSOR UNIT		000-020-737-00 **	
<b>予備品</b>			
<b>SPARE PARTS</b>			
予備品		SP24-00601	1
SPARE PARTS		001-170-660-00	(*1)
予備品		SP24-00602	1
SPARE PARTS		001-170-670-00	(*1)
<b>付属品</b>			
<b>ACCESSORIES</b>			
付属品		FP24-00603	1
ACCESSORIES		001-285-760-00	
<b>工事材料</b>			
<b>INSTALLATION MATERIALS</b>			
ケーブル(クミヒン)		DSUB9P-X2-L5M	1
CABLE ASSEMBLY		000-176-663-11	
ケーブル組品LAN		MOD-Z072-005+	1
LAN CABLE ASSEMBLY		000-174-113-10	
工事材料		CP24-02101	1
INSTALLATION MATERIALS		001-170-630-00	





1.コード番号末尾の[\*\*]は、選択品の代表コードを表します。

1.CODE NUMBER ENDING WITH "\*\*" INDICATES THE CODE NUMBER OF REPRESENTATIVE MATERIAL.

2.(\*1)は、それぞれ仕様選択品を表します。

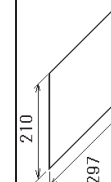
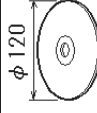
2.(\*1)INDICATE SPECIFICATION SELECTIVE ITEM.

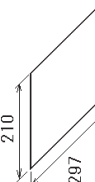
(略図の寸法は、参考値です。DIMENSIONS IN DRAWING FOR REFERENCE ONLY.)

NAME	OUTLINE	DESCRIPTION/CODE No.	Q'TY
電源ケーブル		IEC60320-C13-L5M	1
AC CABLE		000-176-423-11	
<b>図書</b>			
<b>DOCUMENT</b>			
ドングルソフトウェアダウンロード			1
DONGLE INFORMATION SHEET		999-999-085-0*	(*)
取扱説明CD		FAR3XXX O/M *CD-ROM*	1
OPERATOR'S MANUAL CD		000-178-766-1*	
操作要領書		OS*-36160-*	1
OPERATOR'S GUIDE		000-178-028-1* **	
装備設定要領書		*32-01305-*	1
INSTRUCTION MANUAL		000-178-045-1* **	
装備要領書		IM*-36160-*	1
INSTALLATION MANUAL		000-178-030-1* **	

3.(\*)は、ダミーコードに付き、注文できません。



3.(\*) THIS CODE CANNOT BE ORDERED.

# PACKING LIST

XN12CF

03HL-X-9851 -0 1/1

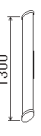
A-2

NAME	UNIT	OUTLINE	DESCRIPTION/CODE No.	Q'TY
ユニット アンテナ				
ANTENNA RADIATOR ASSEMBLY			XN12CF	1
			001-252-640-00 **	
<b>工事材料</b> INSTALLATION MATERIALS				
工事材料			CP03-35201	1
INSTALLATION MATERIALS			001-249-860-00	

コード番号末尾の[\*\*]は、選択品の代表コードを表します。

CODE NUMBER ENDING WITH "\*\*" INDICATES THE CODE NUMBER OF REPRESENTATIVE MATERIAL.

型式/コード番号が2段の場合、下段より上段に代わる過渡期品であり、どちらかが入っています。なお、品質は変わりません。

TWO TYPES AND CODES MAY BE LISTED FOR AN ITEM. THE LOWER PRODUCT MAY BE SHIPPED IN PLACE OF THE UPPER PRODUCT. QUALITY IS THE SAME.

(略図の寸法は、参考値です。DIMENSIONS IN DRAWING FOR REFERENCE ONLY.)



C3616-Z01-A

# PACKING LIST

XN20CF/-HK

03HL-X-9852 -0 1/1

A-3

NAME	UNIT	OUTLINE	DESCRIPTION/CODE No.	Q'TY
ユニット アンテナ				
ANTENNA RADIATOR ASSEMBLY			XN20CF	1
			001-252-650-00 **	
<b>工事材料</b> INSTALLATION MATERIALS				
工事材料			CP03-35201	1
INSTALLATION MATERIALS			001-249-860-00	

コード番号末尾の[\*\*]は、選択品の代表コードを表します。

CODE NUMBER ENDING WITH "\*\*" INDICATES THE CODE NUMBER OF REPRESENTATIVE MATERIAL.

型式/コード番号が2段の場合、下段より上段に代わる過渡期品であり、どちらかが入っています。なお、品質は変わりません。



TWO TYPES AND CODES MAY BE LISTED FOR AN ITEM. THE LOWER PRODUCT MAY BE SHIPPED IN PLACE OF THE UPPER PRODUCT. QUALITY IS THE SAME.

(略図の寸法は、参考値です。DIMENSIONS IN DRAWING FOR REFERENCE ONLY.)

C3616-Z02-A

## PACKING LIST

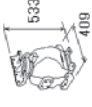
XN24CF/-HK  
RSB-128-105N\* , RSB-128-105N\*\*HK , RSB-128-106N\* , RSB-128-106N\*\*HK  
A-5

NAME	UNIT	OUTLINE	DESCRIPTION/CODE No.	Q'TY
ユニット 空中線本体部 SCANNER UNIT			RSB-128*N* 000-024-105-00 **	1
工事材料 INSTALLATION MATERIALS				
工事材料 INSTALLATION MATERIALS			CP03-35401 001-507-920-00	1
図書 吊下締付要領 HOIST X-BAND, TIGHTEN BOLSTS				
			C32-01302-* 000-178-042-1*	1



コード番号末尾の[\*]\*\*は、選択品の代表コードを表します。  
CODE NUMBER ENDING WITH ".\*" INDICATES THE CODE NUMBER OF REPRESENTATIVE MATERIAL.

(略図の寸法は、参考値です。 DIMENSIONS IN DRAWING FOR REFERENCE ONLY.)

C3616-Z08-D

## PACKING LIST

XN24CF/-HK  
RSB-128-105N\* , RSB-128-105N\*\*HK , RSB-128-106N\* , RSB-128-106N\*\*HK  
A-4

NAME	UNIT	OUTLINE	DESCRIPTION/CODE No.	Q'TY
ユニット アンテナ ANTENNA RADIATOR ASSEMBLY			XN24CF 001-252-660-00 **	1
工事材料 INSTALLATION MATERIALS				
工事材料 INSTALLATION MATERIALS			CP03-35201 001-249-860-00	1

コード番号末尾の[\*]\*\*は、選択品の代表コードを表します。  
CODE NUMBER ENDING WITH ".\*" INDICATES THE CODE NUMBER OF REPRESENTATIVE MATERIAL.

型式/コード番号が2段の場合、下段より上段に代わる過渡期品であり、どちらかが入っています。なお、品質は変わりません。  
TWO TYPES AND CODES MAY BE LISTED FOR AN ITEM. THE LOWER PRODUCT MAY BE SHIPPED IN PLACE OF THE UPPER PRODUCT. QUALITY IS THE SAME.



(略図の寸法は、参考値です。 DIMENSIONS IN DRAWING FOR REFERENCE ONLY.)

C3616-Z03-A

## PACKING LIST

RSB-128-1051\* , RSB-128-1051\*HK , RSB-128-1061\* , RSB-128-1061\*HK

A-6

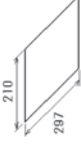
NAME	OUTLINE	DESCRIPTION/CODE No.	QTY
<b>ユニット</b>			
空中線本体部 SCANNER UNIT		RSB-128*1* 000-024-106-00 **	1
<b>工事材料</b>			
工事材料 INSTALLATION MATERIALS		CP03-35403 001-507-930-00	1
<b>図書</b>			
吊下締付要領 HOIST X-BAND, TIGHTEN BOLSTS		C32-01302-* 000-178-042-1*	1

コード番号末尾の[\*]\*\*]は、選択品の代表コードを表します。  
CODE NUMBER ENDING WITH ".\*" INDICATES THE CODE NUMBER OF REPRESENTATIVE MATERIAL.



(略図の寸法は、参考値です。 DIMENSIONS IN DRAWING FOR REFERENCE ONLY.)

C3616-Z04-E

## PACKING LIST

PSU-014/014L/014HK/014LHK

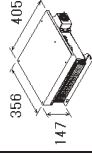
A-7

NAME	OUTLINE	DESCRIPTION/CODE No.	QTY
<b>ユニット</b>			
空中線電源部 POWER SUPPLY UNIT		PSU-014/HK 000-023-893-00 **	1
<b>予備品</b>			
予備品 SPARE PARTS		SP03-17641 001-249-740-00	1
<b>工事材料</b>			
工事材料 INSTALLATION MATERIALS		CP03-35301 001-249-770-00	1

コード番号末尾の[\*]\*\*]は、選択品の代表コードを表します。  
CODE NUMBER ENDING WITH ".\*" INDICATES THE CODE NUMBER OF REPRESENTATIVE MATERIAL.

型式/コード番号が異なる場合、下段より上段に代わる過渡部品であり、どちらかが入っています。なお、品質は変わりません。  
TWO TYPES AND CODES MAY BE LISTED FOR AN ITEM. THE LOWER PRODUCT MAY BE SHIPPED IN PLACE OF THE UPPER PRODUCT. QUALITY IS THE SAME.



(略図の寸法は、参考値です。 DIMENSIONS IN DRAWING FOR REFERENCE ONLY.)

C3616-Z05-C

## PACKING LIST

RCU-025/-HK

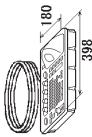
A-8

NAME	UNIT	OUTLINE	DESCRIPTION/CODE No.	Q'TY
ユニット レーダー操作部	RADAR CONTROL UNIT		RCU-025/-HK 000-027-664-00 **	1
付属品	ACCESSORIES		FP24-00701 001-418-340-00	1
工事材料	INSTALLATION MATERIALS			
ケーブル(クミヒ)USB	CABLE ASSEMBLY		TS-20-071-1 L=5000 000-176-700-11	1
工事材料	INSTALLATION MATERIALS		CP24-02201 001-418-330-00	1

コード番号末尾の[\*\*]は、選択品の代表コードを表します。

CODE NUMBER ENDING WITH "\*\*" INDICATES THE CODE NUMBER OF REPRESENTATIVE MATERIAL.

型式/コード番号が2段の場合、下段より上段に代わる過渡期品であり、どちらが入っています。なお、品質は変わりません。

TWO TYPES AND CODES MAY BE LISTED FOR AN ITEM. THE LOWER PRODUCT MAY BE SHIPPED IN PLACE OF THE UPPER PRODUCT. QUALITY IS THE SAME.

(略図の寸法は、参考値です。 DIMENSIONS IN DRAWING FOR REFERENCE ONLY.)



CN

C4473-Z32-A

## PACKING LIST

RCU-026/-HK

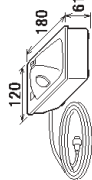
A-9

NAME	UNIT	OUTLINE	DESCRIPTION/CODE No.	Q'TY
ユニット トラックボール操作部	TRACKBALL CONTROL UNIT		RCU-026/-HK 000-027-666-00 **	1
付属品	ACCESSORIES		FP24-00801 001-418-410-00	1
工事材料	INSTALLATION MATERIALS			
ケーブル(クミヒ)USB	CABLE ASSEMBLY		TS-20-071-1 L=5000 000-176-700-11	1
工事材料	INSTALLATION MATERIALS		CP24-02301 001-418-400-00	1

コード番号末尾の[\*\*]は、選択品の代表コードを表します。

CODE NUMBER ENDING WITH "\*\*" INDICATES THE CODE NUMBER OF REPRESENTATIVE MATERIAL.

型式/コード番号が2段の場合、下段より上段に代わる過渡期品であり、どちらが入っています。なお、品質は変わりません。

TWO TYPES AND CODES MAY BE LISTED FOR AN ITEM. THE LOWER PRODUCT MAY BE SHIPPED IN PLACE OF THE UPPER PRODUCT. QUALITY IS THE SAME.

(略図の寸法は、参考値です。 DIMENSIONS IN DRAWING FOR REFERENCE ONLY.)

CN

C4473-Z33-A

CODE NO.	001-170-630-00	24AL-X-9401-2	1/1
TYPE	CP24-02101		

**工事材料表**

番号 NO.	名称 NAME	略図 OUTLINE	型名/規格 DESCRIPTIONS	数量 QTY	用途/備考 REMARKS
1	配線板1 WIRING PLATE 1		24-014-0104-2 CODE NO. 100-366-012-10	1	
2	筐体足1 CHASSIS BASE 1		24-014-0121-1 CODE NO. 100-367-721-10	1	
3	筐体足2 CHASSIS BASE 2		24-014-0122-1 CODE NO. 100-372-171-10	1	
4	配線板2組立品 WIRING PLATE 2 ASSY		CP24-02102 CODE NO. 001-166-200-00	1	
5	ケーブル CABLE TIE		CV-100N CODE NO. 000-162-167-10	10	
6	ケーブル CABLE TIE		CV-150N CODE NO. 000-162-186-10	30	
7	圧着端子 CRIMP-ON LUG		FVI. 25-4 (LF) RED CODE NO. 000-166-666-10	9	
8	バンドネジ BINDING HEAD SCREW		M2X6 SUS304 CODE NO. 000-162-664-10	5	
9	バンドネジ BINDING HEAD SCREW		M4X8 SUS304 CODE NO. 000-162-669-10	10	











型式/コード番号が2段の場合、下段より上段に代わる通電部品であり、どちらが入っています。なお、品質は変わりません。  
TWO TYPES AND CODES MAY BE LISTED FOR AN ITEM. THE LOWER PRODUCT MAY BE SHIPPED IN PLACE OF THE UPPER PRODUCT.  
QUALITY IS THE SAME.  
(略図の寸法は、参考値です。 DIMENSIONS IN DRAWING FOR REFERENCE ONLY.)

CODE NO.	001-249-860-00	03HL-X-9401-2	1/1
TYPE	CP03-35201		

**工事材料表**

番号 NO.	名称 NAME	略図 OUTLINE	型名/規格 DESCRIPTIONS	数量 QTY	用途/備考 REMARKS
1	ボルト用パッキン GASKET FOR BOLT		03-182-3186-0 CODE NO. 100-386-270-10	6	
2	アンテナ取付ボルト ANTENNA FIXING BOLT		03-182-4188-3 CODE NO. 100-383-603-10	6	
3	シリコン SILICON RUBBER		S-8400M 7#575-7 50G CODE NO. 000-166-483-11	1	











型式/コード番号が2段の場合、下段より上段に代わる通電部品であり、どちらが入っています。なお、品質は変わりません。  
TWO TYPES AND CODES MAY BE LISTED FOR AN ITEM. THE LOWER PRODUCT MAY BE SHIPPED IN PLACE OF THE UPPER PRODUCT.  
QUALITY IS THE SAME.  
(略図の寸法は、参考値です。 DIMENSIONS IN DRAWING FOR REFERENCE ONLY.)

CODE NO.		001-507-920-00		03HL-X-9403 -1	
TYPE		CP03-35401		1/1	
番号 NO.	名称 NAME	略 OUTLINE	型名/規格 DESCRIPTIONS	数量 QTY	用途/備考 REMARKS
1	シールワッシャー SEAL WASHER		03-001-3002-0 ROHS CODE NO. 300-130-020-10	4	
2	絶縁シート1 INSULATION SHEET 1		03-182-3117-2 CODE NO. 100-387-752-10	4	
3	六角ナット 1/2 HEXAGONAL NUT		M12 SUS304 CODE NO. 000-167-491-10	8	
4	ミガキ扁平座金 FLAT WASHER		M12 SUS304 CODE NO. 000-167-446-10	4	
5	六角ヘッド全ネジ HEXAGON HEAD SCREW		M12X70 SUS304 CODE NO. 000-162-814-10	4	
6	六角ナット 1/2 HEXAGONAL NUT		M6 SUS304 CODE NO. 000-158-856-10	1	
7	ハネ座金 SPRING WASHER		M6 SUS304 CODE NO. 000-158-855-10	1	
8	ミガキ扁平座金 FLAT WASHER		M6 SUS304 CODE NO. 000-158-854-10	3	
9	六角ヘッド HEXAGONAL HEAD BOLT		M6X25 SUS304 CODE NO. 000-162-871-10	1	
10	ケーブル組品 CABLE ASSY.		RW-4747 CODE NO. 000-566-000-12	1	

(略図の寸法は、参考値です。 DIMENSIONS IN DRAWING FOR REFERENCE ONLY.)

FURUNO ELECTRIC CO., LTD.

C3616-M02-B



CODE NO.		001-507-930-00		03HL-X-9408 -4	
TYPE		CP03-35403		1/2	
番号 NO.	名称 NAME	略 OUTLINE	型名/規格 DESCRIPTIONS	数量 QTY	用途/備考 REMARKS
1	シールワッシャー SEAL WASHER		03-001-3002-0 ROHS CODE NO. 300-130-020-10	4	
2	絶縁シート1 INSULATION SHEET 1		03-182-3117-2 CODE NO. 100-387-752-10	4	
3	圧着端子 CRIMP-ON LUG		FV2-M4 CODE NO. 000-157-229-10	2	
4	ロッキングワイヤサドル LOCKING WIRE SADDLE		LWS-1211Z CODE NO. 000-167-788-11	2	
5	六角ナット 1/2 HEXAGONAL NUT		M12 SUS304 CODE NO. 000-167-491-10	8	
6	ミガキ扁平座金 FLAT WASHER		M12 SUS304 CODE NO. 000-167-446-10	4	
7	六角ヘッド全ネジ HEXAGON HEAD SCREW		M12X70 SUS304 CODE NO. 000-162-814-10	4	
8	六角ナット 1/2 HEXAGONAL NUT		M6 SUS304 CODE NO. 000-158-856-10	1	
9	ハネ座金 SPRING WASHER		M6 SUS304 CODE NO. 000-158-855-10	1	
10	ミガキ扁平座金 FLAT WASHER		M6 SUS304 CODE NO. 000-158-854-10	3	

(略図の寸法は、参考値です。 DIMENSIONS IN DRAWING FOR REFERENCE ONLY.)

FURUNO ELECTRIC CO., LTD.

C3616-M01-E(1)

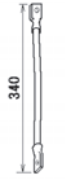



CODE NO.		001-507-930-00		03HL-X-9408-4	
TYPE		CP03-35403		2/2	
工事材料表					
INSTALLATION MATERIALS					
番号 NO.	名称 NAME	略図 OUTLINE	型名/規格 DESCRIPTIONS	数量 Q'TY	用途/備考 REMARKS
11	六角ボルト HEXAGONAL HEAD BOLT		M6X25 SUS304 CODE NO. 000-162-871-10	1	
12	ケーブル組品 CABLE ASSY.		RW-4747 CODE NO. 000-566-000-12	1	
13	スパイラルチューブ SPIRAL TUBE		SPN-08L #800MM* CODE NO. 000-179-640-10	1	

(略図の寸法は、参考値です。 DIMENSIONS IN DRAWING FOR REFERENCE ONLY.)

FURUNO ELECTRIC CO., LTD.

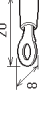
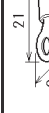
C3616-M01-E (2)

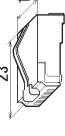
CODE NO.		001-249-770-00		03HL-X-9405-0	
TYPE		CP03-35301		1/1	
工事材料表					
INSTALLATION MATERIALS					
番号 NO.	名称 NAME	略図 OUTLINE	型名/規格 DESCRIPTIONS	数量 Q'TY	用途/備考 REMARKS
1	圧着端子 OR IMP-ON LUG		FV1.25-4(LF) RED CODE NO. 000-166-666-10	1	
2	圧着端子 OR IMP-ON LUG		FV2-4 BLU CODE NO. 000-167-247-10	3	
3	圧着端子 OR IMP-ON LUG		FV2-M3 BLU CODE NO. 000-167-250-10	1	
4	コネクタ(モジュラー) MODULAR CONNECTOR		MPS568-C CODE NO. 000-166-044-10	3	

型式/コード番号が2版の場合、下版より上版に代わる選定部品であり、どちらが入っています。なお、品質は変わりません。

TWO TYPES AND CODES MAY BE LISTED FOR AN ITEM. THE LOWER PRODUCT MAY BE SHIPPED IN PLACE OF THE UPPER PRODUCT. QUALITY IS THE SAME.  
(略図の寸法は、参考値です。 DIMENSIONS IN DRAWING FOR REFERENCE ONLY.)

FURUNO ELECTRIC CO., LTD.





C3618-M04-A

**FURUNO**

CODE NO.	03HL-X-9406-0	1/1
TYPE		

**工事材料表**

FAIR-3210/3210-BB/3310/3220/3220-BB/3320/3230S/3230S-BB/3330S/3330S-SSD/3230S-BB/3330S/3330S-SSD

番号 NO.	名称 NAME	略図 OUTLINE	型名/規格 DESCRIPTIONS	数量 QTY	用途/備考 REMARKS
1	ケーブル(組品) CABLE ASSEMBLY		RM-00135-L15M CODE NO. 0017-259-880-00	1	選択 TO BE SELECT
2	ケーブル(組品) CABLE ASSEMBLY		RM-00135-L30M CODE NO. 0017-259-880-00	1	選択 TO BE SELECT
3	ケーブル(組品) CABLE ASSEMBLY		RM-00135-L40M CODE NO. 0017-259-870-00	1	選択 TO BE SELECT
4	ケーブル(組品) CABLE ASSEMBLY		RM-00135-L50M CODE NO. 0017-259-880-00	1	選択 TO BE SELECT

型式/コード番号が2段の場合、下段より上段に代わる標準部品であり、どちらかが入っています。なお、品質は変わりません。  
TWO TYPES AND CODES MAY BE LISTED FOR AN ITEM. THE LOWER PRODUCT MAY BE SHIPPED IN PLACE OF THE UPPER PRODUCT.  
QUALITY IS THE SAME.  
(略図の寸法は、参考値です。 DIMENSIONS IN DRAWING FOR REFERENCE ONLY.)

FURUNO ELECTRIC CO., LTD.

C3618-M05-A

**FURUNO**

CODE NO.	001-418-330-00	24AL-X-9408-0
TYPE	CP24-02201	1/1

**工事材料表**

INSTALLATION MATERIALS

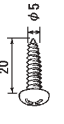
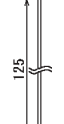
番号 NO.	名称 NAME	略図 OUTLINE	型名/規格 DESCRIPTIONS	数量 QTY	用途/備考 REMARKS
1	セルフタッピングネジ SELF-TAPPING SCREW		SX20 SXS04 CODE NO. 000-162-608-10	2	
2	ケーブルツガ CABLE TIE		CT-125N CODE NO. 000-172-164-10	2	

型式/コード番号が2段の場合、下段より上段に代わる標準部品であり、どちらかが入っています。なお、品質は変わりません。  
TWO TYPES AND CODES MAY BE LISTED FOR AN ITEM. THE LOWER PRODUCT MAY BE SHIPPED IN PLACE OF THE UPPER PRODUCT.  
QUALITY IS THE SAME.  
(略図の寸法は、参考値です。 DIMENSIONS IN DRAWING FOR REFERENCE ONLY.)



FURUNO ELECTRIC CO., LTD.

CN  
C4473-M08-A

**FURUNO**

CODE NO.	001-418-400-00	24AL-X-9409-0	1/1
TYPE	CP24-02301		

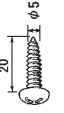
**工事材料表**

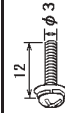

INSTALLATION MATERIALS					
番号 NO.	名称 NAME	略図 OUTLINE	型名/規格 DESCRIPTIONS	数量 QTY	用途/備考 REMARKS
1	+self-tapping screw 1/2 SELF-TAPPING SCREW		5X20 SUS304 CODE NO. 000-162-608-10	2	
2	ケーブルタイ CABLE TIE		CV-125N CODE NO. 000-172-164-10	2	
3	+self-washer WASHER HEAD SCREW #8*		MX12 SUS304 CODE NO. 000-162-648-10	4	

型式/コード番号が2原の場合、下段より上段に代わる運送期品であり、どちらが入っています。なお、品質は変わりません。  
TWO TYPES AND CODES MAY BE LISTED FOR AN ITEM. THE LOWER PRODUCT MAY BE SHIPPED IN PLACE OF THE UPPER PRODUCT.  
QUALITY IS THE SAME.  
(略図の寸法は、参考値です。 DIMENSIONS IN DRAWING FOR REFERENCE ONLY.)

**FURUNO**

CODE NO.	001-418-340-00	24AL-X-9511-0	1/1
TYPE	FP24-00701		

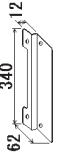
**付属品表**

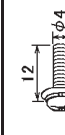
ACCESSORIES					
番号 NO.	名称 NAME	略図 OUTLINE	型名/規格 DESCRIPTIONS	数量 QTY	用途/備考 REMARKS
1	卓上取付板 DESK FIXING PLATE		24-014-1401-0 CODE NO. 100-367-460-10	1	
2	USBポート USB SHEET		24-014-1411-0 CODE NO. 100-372-000-10	1	
3	+self-washer WASHER HEAD SCREW #8*		MX12 CZ700N MBN12 CODE NO. 000-163-192-10	4	



型式/コード番号が2原の場合、下段より上段に代わる運送期品であり、どちらが入っています。なお、品質は変わりません。  
TWO TYPES AND CODES MAY BE LISTED FOR AN ITEM. THE LOWER PRODUCT MAY BE SHIPPED IN PLACE OF THE UPPER PRODUCT.  
QUALITY IS THE SAME.  
(略図の寸法は、参考値です。 DIMENSIONS IN DRAWING FOR REFERENCE ONLY.)

**FURUNO**

CODE NO.	1001-418-410-00	24AL-X-9512-0
TYPE	FP24-00801	1/1

**付属品表**

## ACCESSORIES

番号 NO.	名称 NAME	略図 OUTLINE	型名/規格 DESCRIPTIONS	数量 QTY	用途/備考 REMARKS
1	卓上取付板 DESKTOP FIXING PLATE	100 	14-078-2311-0 CODE NO. 100-364-730-10	1	
2	USBシート USB SHEET	15 	24-014-1411-0 CODE NO. 100-372-000-10	1	
3	+F4 TEL28 WASHER HEAD SCREW #8*	8 	M3X8 SUS304 CODE NO. 000-162-649-10	2	

型式/コード番号が2取の場合、下取より上取に代わる運送部品であり、どちらが入っています。なお、品質は変わりません。

TWO TYPES AND CODES MAY BE LISTED FOR AN ITEM. THE LOWER PRODUCT MAY BE SHIPPED IN PLACE OF THE UPPER PRODUCT. QUALITY IS THE SAME. DIMENSIONS IN DRAWING FOR REFERENCE ONLY.)

(略図の寸法は、参考値です。)

FURUNO ELECTRIC CO., LTD.

ON

C4473-F10-A

表 1 TABLE 1

寸法区分 (mm) DIMENSION	公差 (mm) TOLERANCE
L ≤ 50	±1.5
50 < L ≤ 100	±2.5
100 < L ≤ 500	±3
500 < L ≤ 1000	±4
1000 < L ≤ 2000	±5
2000 < L ≤ 4000	±7

表 2 TABLE 2

アンテナ型式 ANTENNA TYPE	XN120CF (120cm型)	XN200CF (200cm型)	XN240CF (240cm型)
A: 空中線長 ANTENNA LENGTH	1,300±10mm	2,100±10mm	2,600±10mm
B: 回転安全層 ANTENNA CLEARANCE	1,500mm	2,300mm	2,800mm
総質量 (±10%) TOTAL MASS	48.6kg	50.7kg	51.9kg

補強リブの板厚は取付台の半分程度。  
溶接は、取付用ボルト・平座金の座面  
にかかからねこと。  
補強リブはマスト支柱中心と取付穴の  
中心を結ぶ方向に取り付けること。

THICKNESS OF RIB: t/2 (HALF OF PLATFORM PLATE)  
AVOID BOLT & WASHER LOCATIONS ON THE PLATFORM  
WHEN WELDING THE RIBS.  
THE RIBS SHOULD BE WELDED IN THE LINE WITH  
THE STANCHION CENTER AND FIXING HOLES CENTER.

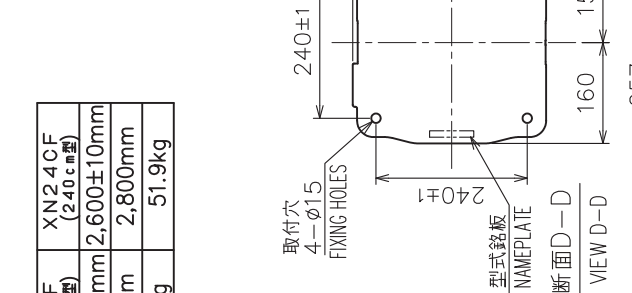

取付台 (参考)  
PLATFORM (FOR REFERENCE)

船首方向  
BOW

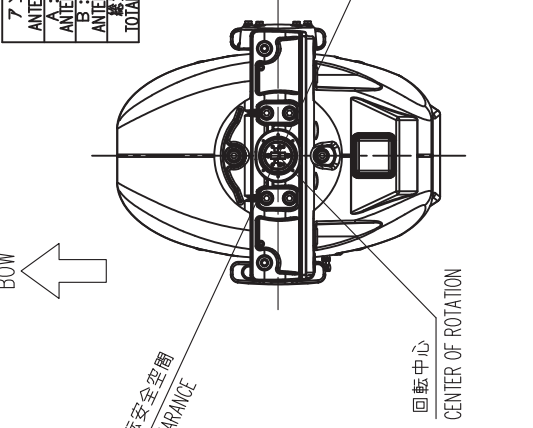

PMアンテナ (PMありの時)  
PM ANTENNA (PM CONFIG. ONLY)

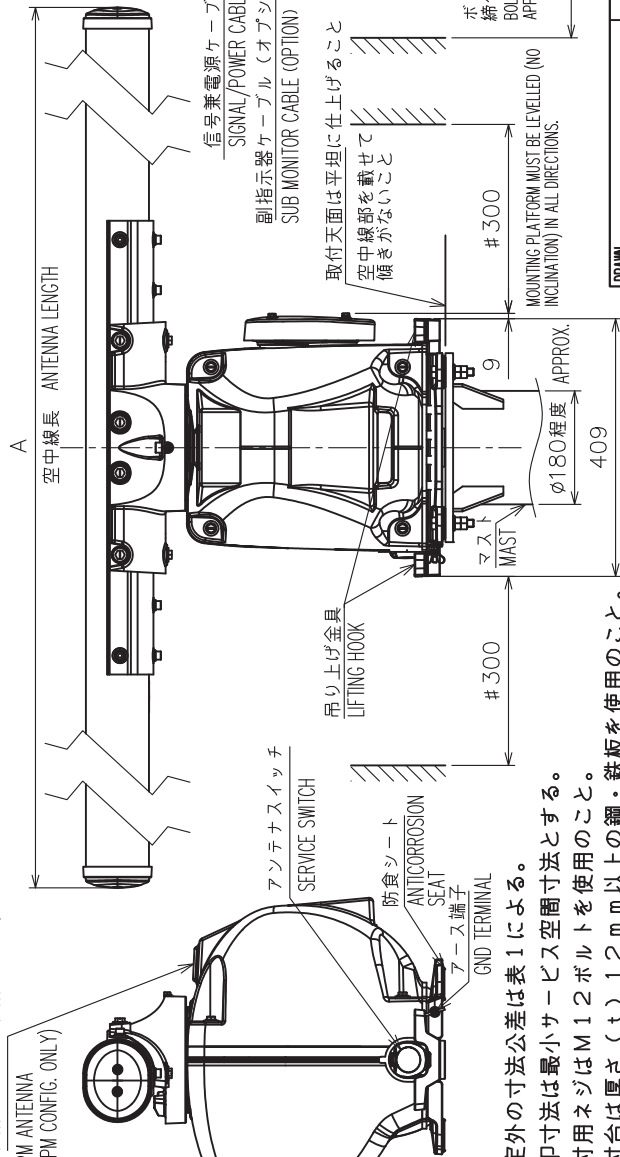

- 注 記
- 1) 指定外の寸法公差は表 1 による。
  - 2) # 印寸法は最小サービスマン寸法とする。
  - 3) 取付用ネジは M12 ボルトを使用のこと。
  - 4) 取付台は厚さ (t) 12mm 以上の鋼・鉄板を使用のこと。

NOTE

1. TABLE 1 INDICATES TOLERANCE OF DIMENSIONS WHICH IS NOT SPECIFIED.
2. # MINIMUM SERVICE CLEARANCE.
3. USE M12 BOLTS FOR FIXING THE UNIT.
4. THICKNESS OF PLATFORM (t): 12 mm OR MORE STEEL PLATE.

DRAWN	6/Nov/2017	T.YAMASAKI	TITLE	RSB-128
CHECKED	6/Nov/2017	H.MAKI	名称	空中線部 (PMあり/なし、氷結防止なし)
APPROVED	6/Nov/2017	H.MAKI	外寸図	
SCALE	1/12	ISS 表 2 参照 SEE TABLE 2	NAME	ANTENNA UNIT (PM Y/N, NO DE-ICER)
DWG.No.	C-3616-G02-G	REF.No.	03-182-310G-8	OUTLINE DRAWING

表 1 TABLE 1

寸法区分 (mm)	公差 (mm)
DIMENSION	TOLERANCE
L ≤ 50	±1.5
50 < L ≤ 100	±2.5
100 < L ≤ 500	±3
500 < L ≤ 1000	±4
1000 < L ≤ 2000	±5
2000 < L ≤ 4000	±7

表 2 TABLE 2

アンテナ型式	XN12CF (120cm型)	XN20CF (200cm型)	XN24CF (240cm型)
A: 空中線長	1,300±10mm	2,100±10mm	2,600±10mm
B: 回転安全空間	1,500mm	2,300mm	2,800mm
総質量 (±10%)	49.7kg	51.8kg	53.0kg
TOTAL MASS			

船首方向  
BOW

φB: 回転安全空間  
ANTENNA CLEARANCE

回転中心  
CENTER OF ROTATION

PMアンテナ (PMありの時)  
PM ANTENNA (PM CONFIG. ONLY)

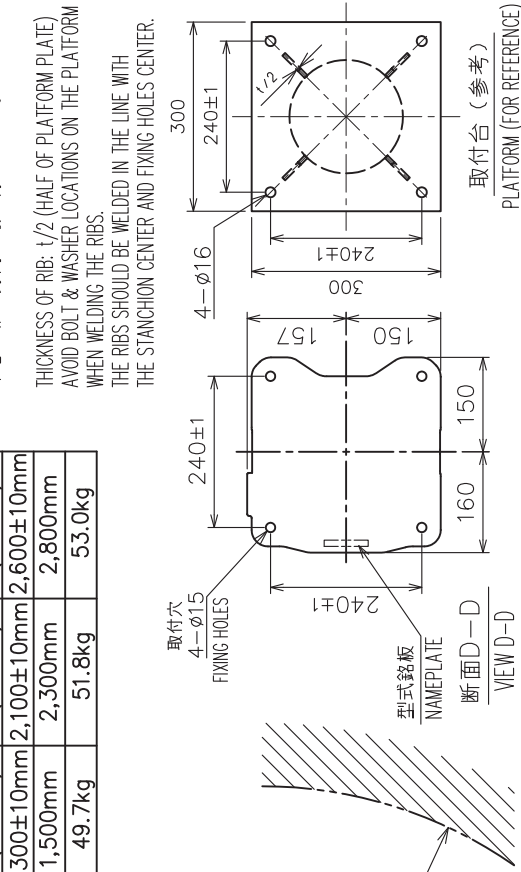

A

空中線長 ANTENNA LENGTH

B

氷結防止ヒーター  
DE-ICER HEATER

C

船首方向  
BOW

氷結防止温度センサー  
TEMPERATURE SENSOR

氷結防止電源ケーブル  
DE-ICER CABLE

アンテナスイッチ  
SERVICE SWITCH

防食ソケット  
ANTICORROSION  
SEAT

マスト  
MAST

吊上げ金具  
LIFTING HOOK

副指示器ケーブル (オプション)  
SUB MONITOR CABLE (OPTION)

信号兼電源ケーブル  
SIGNAL/POWER CABLE

取付台面は平坦に仕上げる  
空中線部を載せて  
傾きがないこと

ボルト、平座金、ナット (2個)  
締付後、シール剤塗布  
BOLT, FLAT WASHER, NUTS (2PCS)  
APPLY SEALANT AFTER FASTENING.

取付台は厚さ (t) 12mm以上の鋼・鉄板を使用のこと。

注記

1) 指定外の寸法公差は表1による。

2) #印寸法は最小サービスクリアランスとする。

3) 取付用ネジはM12ボルトを使用のこと。

4) 取付台は厚さ (t) 12mm以上の鋼・鉄板を使用のこと。

NOTE

1. TABLE 1 INDICATES TOLERANCE OF DIMENSIONS WHICH IS NOT SPECIFIED.

2. # MINIMUM SERVICE CLEARANCE.

3. USE M12 BOLTS FOR FIXING THE UNIT.

4. THICKNESS OF PLATFORM (t): 12 mm OR MORE STEEL PLATE.

2

3

4

5

6

7

8

9

10

11

12

13

14

15

16

17

18

19

20

21

22

23

24

25

26

27

28

29

30

31

32

33

34

35

36

37

38

39

40

41

42

43

44

45

46

47

48

49

50

51

52

53

54

55

56

57

58

59

60

61

62

63

64

65

66

67

68

69

70

71

72

73

74

75

76

77

78

79

80

81

82

83

84

85

86

87

88

89

90

91

92

93

94

95

96

97

98

99

100

101

102

103

104

105

106

107

108

109

110

111

112

113

114

115

116

117

118

119

120

121

122

123

124

125

126

127

128

129

130

131

132

133

134

135

136

137

138

139

140

141

142

143

144

145

146

147

148

149

150

151

152

153

154

155

156

157

158

159

160

161

162

163

164

165

166

167

168

169

170

171

172

173

174

175

176

177

178

179

180

181

182

183

184

185

186

187

188

189

190

191

192

193

194

195

196

197

198

199

200

201

202

203

204

205

206

207

208

209

210

211

212

213

214

215

216

217

218

219

220

221

222

223

224

225

226

227

228

229

230

231

232

233

234

235

236

237



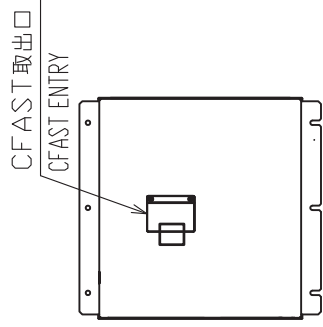
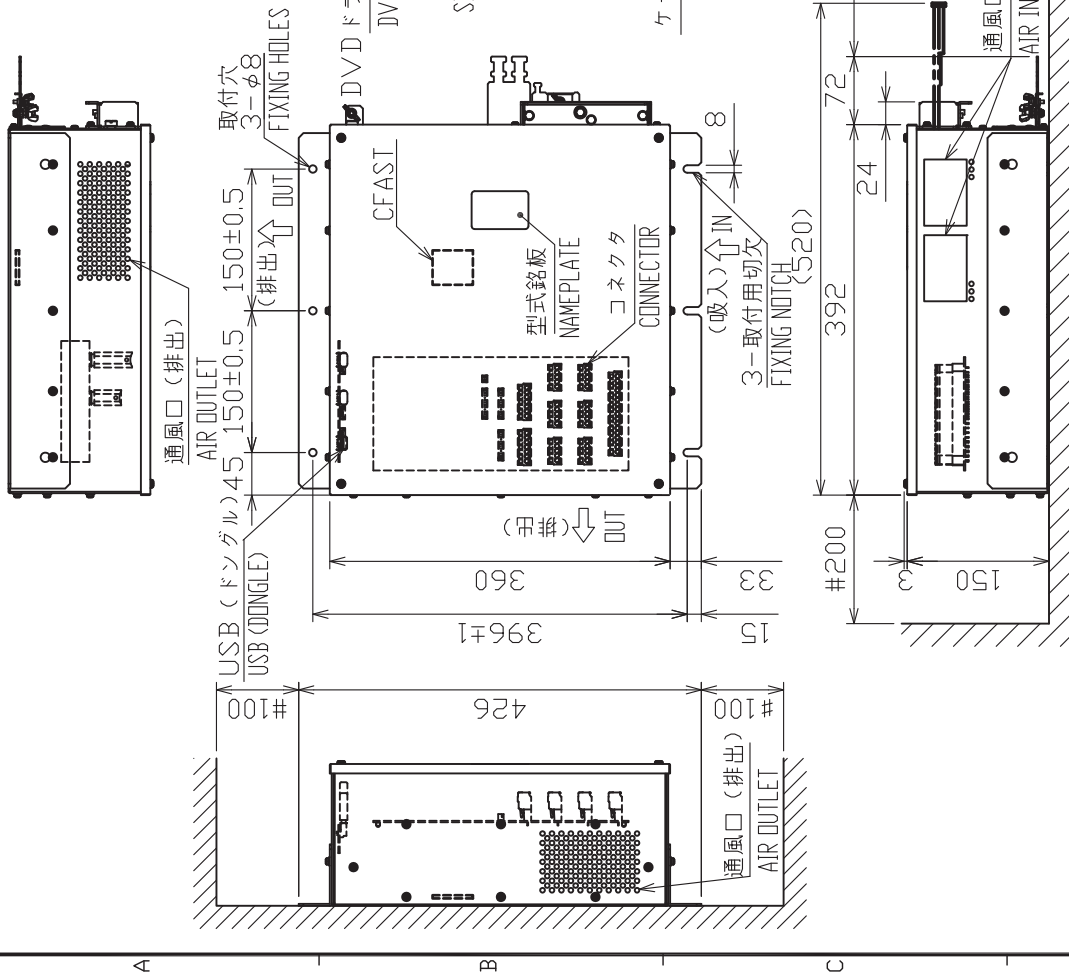

背面 (尺度: 1/12)  
REAR VIEW (SCALE: 1/12)

表 1 TABLE 1

寸法区分 (mm) DIMENSION	公差 (mm) TOLERANCE
L ≤ 50	±1.5
50 < L ≤ 100	±2.5
100 < L ≤ 500	±3

下図の向きでは取付けできません  
DO NOT MOUNT FOLLOWING DIRECTIONS

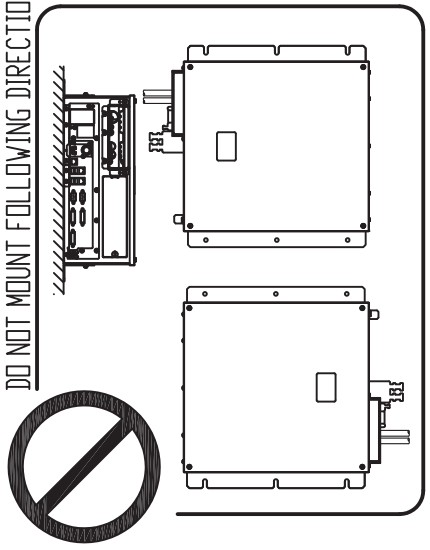

注 記

- 1) 指定外の寸法公差は表 1 による。
- 2) # 印寸法は最小サービス空間寸法とする。
- 3) 取付用ネジは M6 ボルトまたはコーネジ呼び径φ6 を使用のこと。
- 4) DVD ドライブの向きは左右いずれかとする。切欠きが下向きとなるよう取付金具 (工材) を本体に取り付ける。

NOTE

1. TABLE 1 INDICATES TOLERANCE OF DIMENSIONS WHICH IS NOT SPECIFIED.
2. # MINIMUM SERVICE CLEARANCE.
3. USE M6 BOLTS OR CORNER SCREWS φ6 FOR FIXING THE UNIT.
4. FACE THE DVD DRIVE TO RIGHT OR LEFT SIDE EITHER. MOUNT THE FIXING PLATES (SUPPLIED) TO THE CHASSIS AS THE FIXING NOTCH FACES TO BOTTOM.

DRAWN	29/Nov/2017 T.YAMASAKI	TITLE	EC-3000
CHECKED	29/Nov/2017 H.HAKI	各種	制御部 (壁掛装備)
APPROVED	29/Nov/2017 H.HAKI	外寸図	
SCALE	1/8 MASS 14 30Z 1g	NAME	PROCESSOR UNIT (BULKHEAD MOUNT)
FIG.No.	C4473-G01-D	REF.No.	24-014-011G-3
			OUTLINE DRAWING



表1 TABLE 1

寸法区分 (mm) DIMENSION	公差 (mm) TOLERANCE
$L \leq 50$	$\pm 1.5$
$50 < L \leq 100$	$\pm 2.5$
$100 < L \leq 500$	$\pm 3$

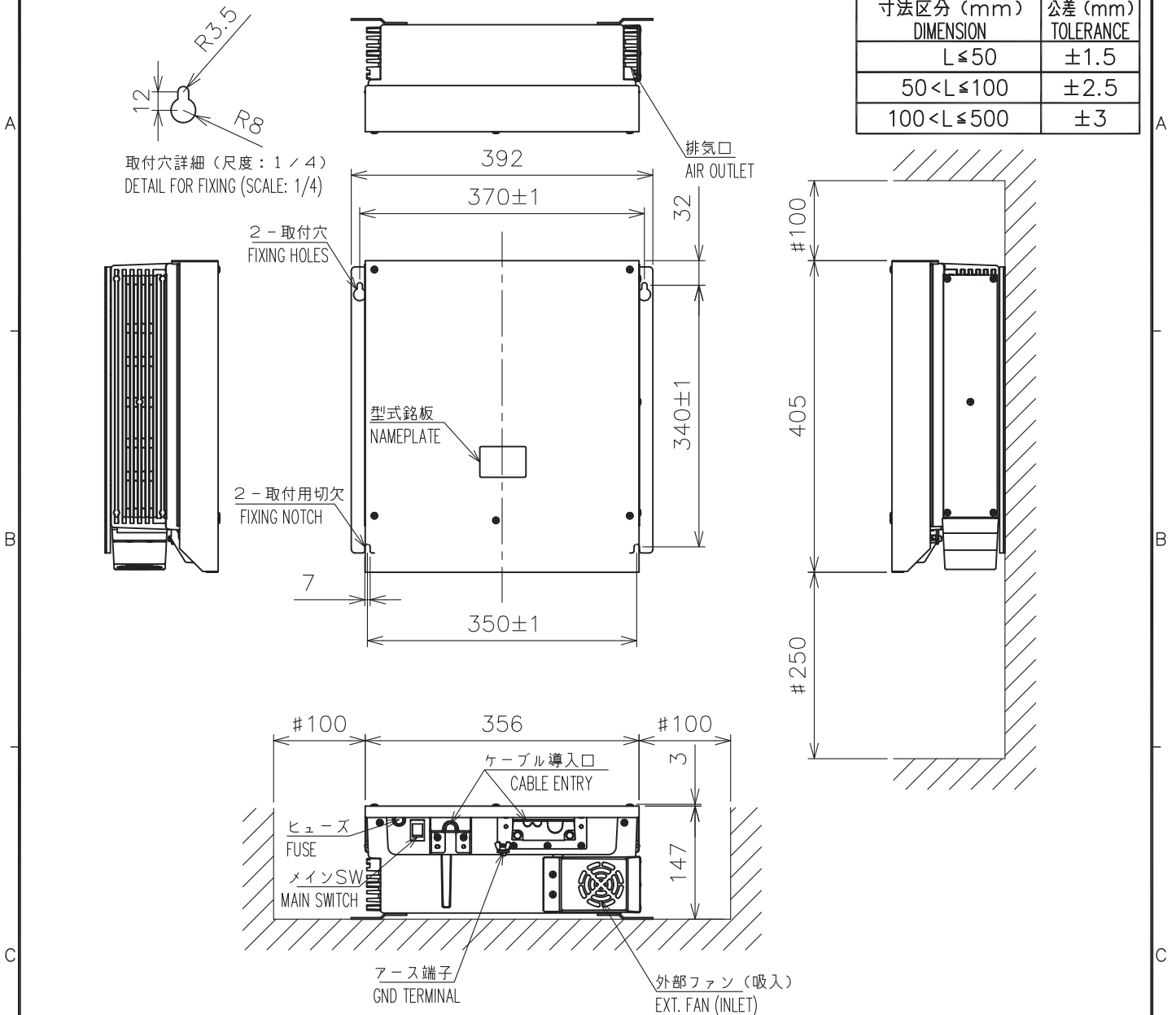

注記

- 1) 指定外の寸法公差は表 1 による。
- 2) # 印寸法は最小サービス空間寸法とする。
- 3) 取付用ネジは M6 ボルトまたはコーチボルト呼び径 6 を使用のこと。

NOTE

1. TABLE 1 INDICATES TOLERANCE OF DIMENSIONS WHICH IS NOT SPECIFIED.
2. #: MINIMUM SERVICE CLEARANCE.
3. USE M6 BOLTS OR COACH SCREWS  $\phi 6$  FOR FIXING THE UNIT.

DRAWN 20/Mar/2014 T.YAMASAKI	TITLE PSU-014/016
CHECKED 20/Mar/2014 H.MAKI	名称 空中線電源部
APPROVED 24/Mar/2014 H.MAKI	FAR-3210/3220 ser. 外寸図
SCALE 1/8	MASS 8.5 ±10% kg
DWG. No. C3616-G01-B	REF. No. 03-182-910G-3
NAME POWER SUPPLY UNIT OUTLINE DRAWING	

電源・信号ケーブル (5 m)

POWER/SIGNAL CABLE

USBケーブル

USB CABLE

308±0.5

取付穴  
4-M4  
FIXING HOLES

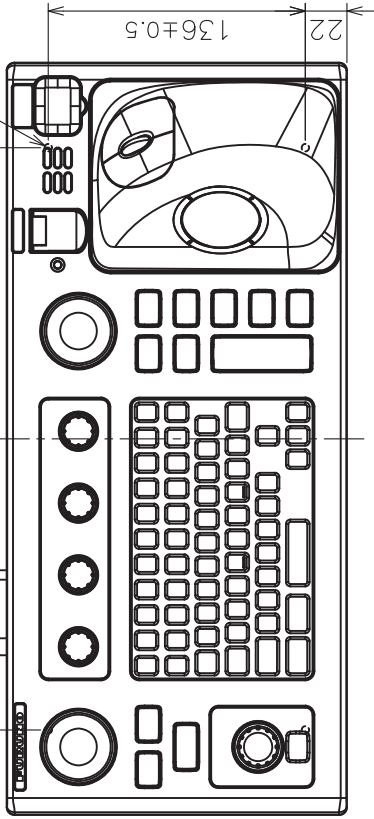

398

10  
ネジ深さ  
THREAD DEPTH

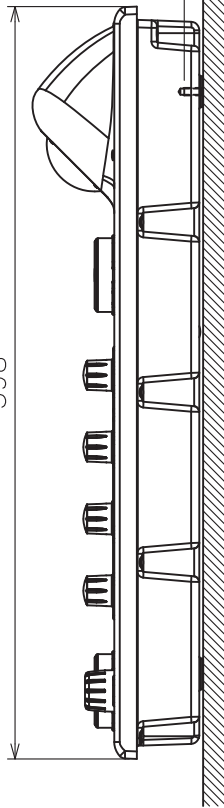

4-% 水抜穴  
DRAIN HOLES

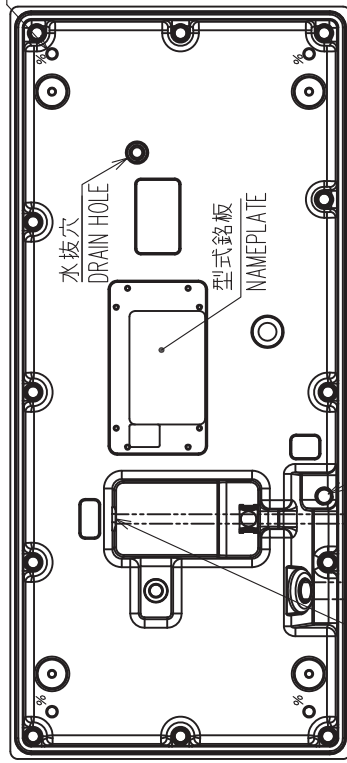

信号コネクタ  
SIGNAL CONNECTOR

アース端子  
GND TERMINAL

表1 TABLE 1

寸法区分 (mm) DIMENSION	公差 (mm) TOLERANCE
L ≤ 50	±1.5
50 < L ≤ 100	±2.5
100 < L ≤ 500	±3

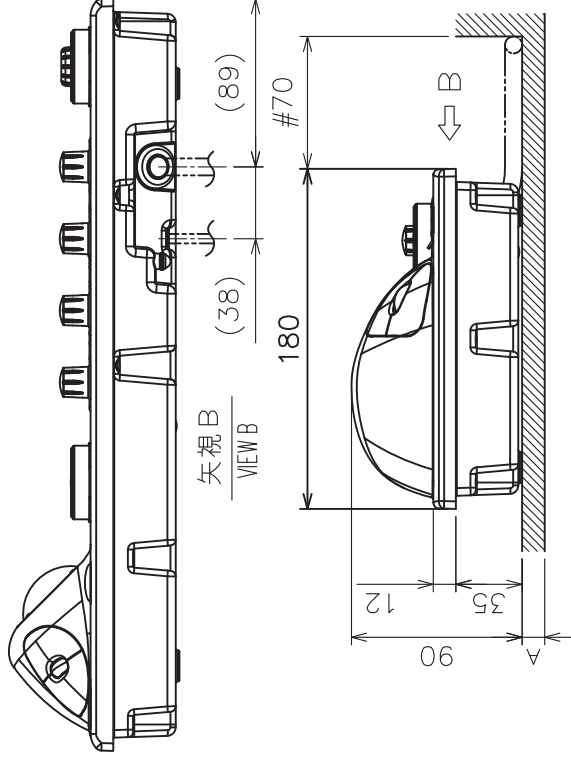

- 注記
- 1) 指定外の寸法公差は表1による。
  - 2) #印寸法は最小サージスペース寸法とする。
  - 3) 取付ネジはセムスネジB M4×1.2を使用のこと。  
壁の厚さ(A)は最小2mm、最大4mmとする。  
それ以外の場合は、M4×(A(壁の厚さ)+8±2mm)とする。
- NOTE
1. TABLE 1 INDICATES TOLERANCE OF DIMENSIONS WHICH IS NOT SPECIFIED.
  2. # MINIMUM SERVICE CLEARANCE.
  3. USE SEMS B SCREWS (M4x1.2) FOR BULKHEAD THICKNESS(A); 2 ≤ A ≤ 4 OR SCREW LENGTH: A+8±2.

DRAWN	6/Nov/2012	T.YAMASAKI	TITLE	RCU-024
CHECKED	6/Nov/2012	H.MAKI	名称	ECDIS操作部 (卓上装備)
APPROVED	7/Nov/2012	Y.NISHIYAMA	外寸図	
SCALE	1/4	質量は5mケーブルを含む。 10% 質量は5mケーブルを含む。 MASS INCLUDES 5m CABLE.	NAME	ECDIS CONTROL UNIT (TABLETOP MOUNT)
DWG.No.	C4473-G02-B	REF.No.	24-014-100G-2	OUTLINE DRAWING

表1 TABLE 1

寸法区分 (mm) DIMENSION	公差 (mm) TOLERANCE
L ≤ 50	±1.5
50 < L ≤ 100	±2.5
100 < L ≤ 500	±3

電源・信号ケーブル (5 m)  
POWER/SIGNAL CABLE

USBケーブル  
USB CABLE

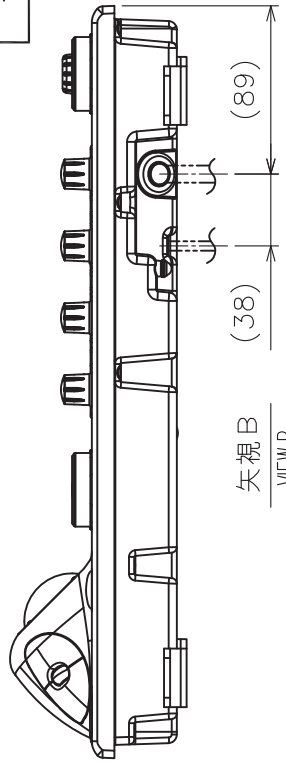
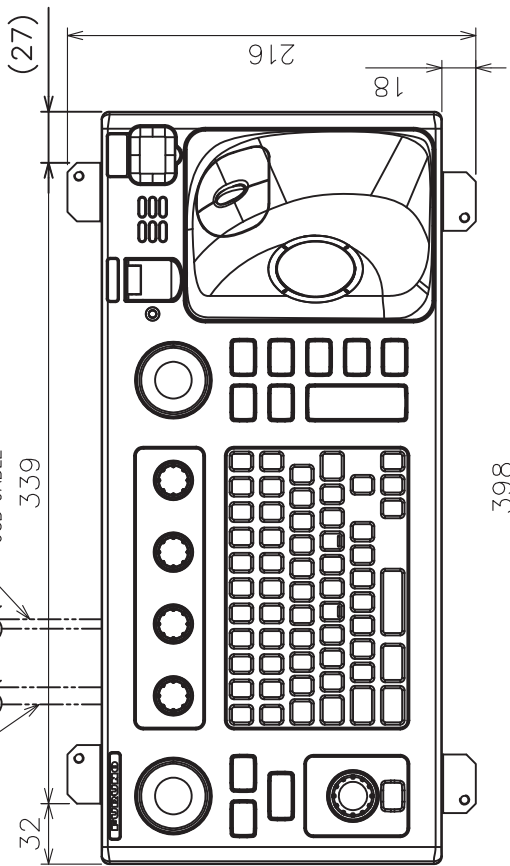

矢視 B  
VIEW B

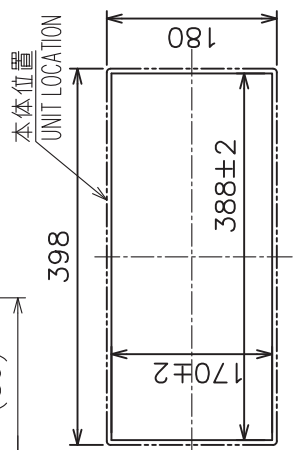

本体位置  
UNIT LOCATION

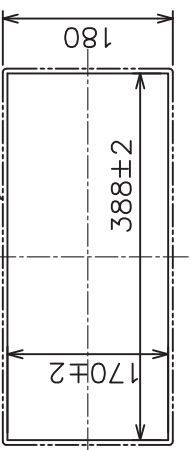
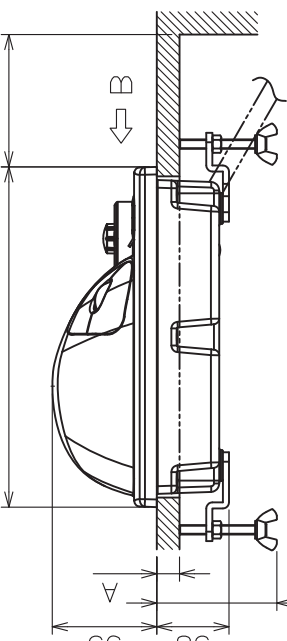

取付寸法 (尺度: 1/8)  
CUTOUT DIMENSIONS (SCALE: 1/8)

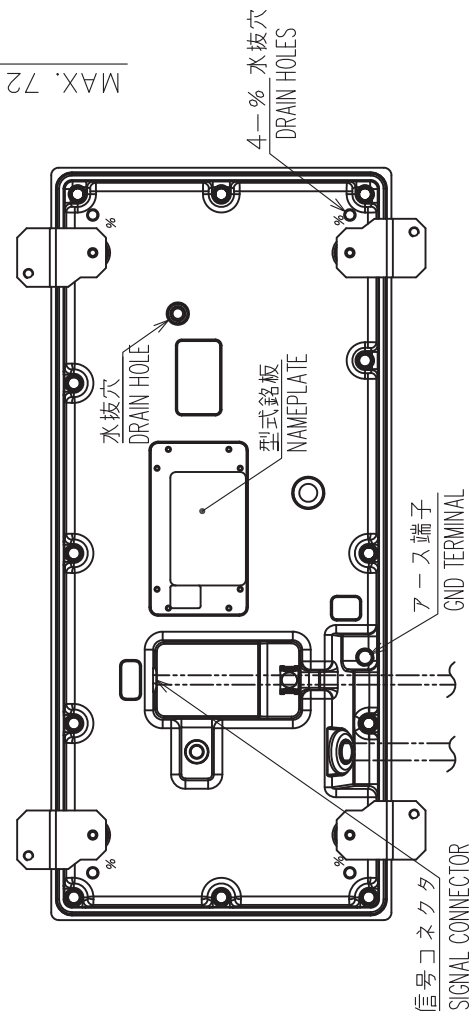

- 注記
- 1) 指定外の寸法公差は表1による。
  - 2) #印寸法は最小サージス空間寸法とする。
  - 3) 壁の厚さ(A)は最小10mm、最大20mmとする。
- NOTE
1. TABLE 1 INDICATES TOLERANCE OF DIMENSIONS WHICH IS NOT SPECIFIED.
  2. # MINIMUM SERVICE CLEARANCE.
  3. BULKHEAD THICKNESS(A): 10 ≤ A ≤ 20

DRAWN	5/Nov/2012	T.YAMASAKI	TITLE	RCU-024
CHECKED	5/Nov/2012	H.MAKI	名称	ECDIS操作部 (埋込装備)
APPROVED	7/Nov/2012	Y.NISHIYAMA	外寸図	
SCALE	1/4	質量は5mmケーブルを含む。 MASS INCLUDES 5m CABLE.	NAME	ECDIS CONTROL UNIT (FLUSH MOUNT)
DMC.No.	C4473-G03-B	REF.No.	24-014-110G-2	OUTLINE DRAWING

信号コネクタ  
SIGNAL CONNECTOR

アース端子  
GND TERMINAL

型式銘板  
NAMEPLATE

4-φ 水抜穴  
DRAIN HOLES



表1 TABLE 1

寸法区分 (mm) DIMENSION	公差 (mm) TOLERANCE
L ≤ 50	±1.5
50 < L ≤ 100	±2.5
100 < L ≤ 500	±3

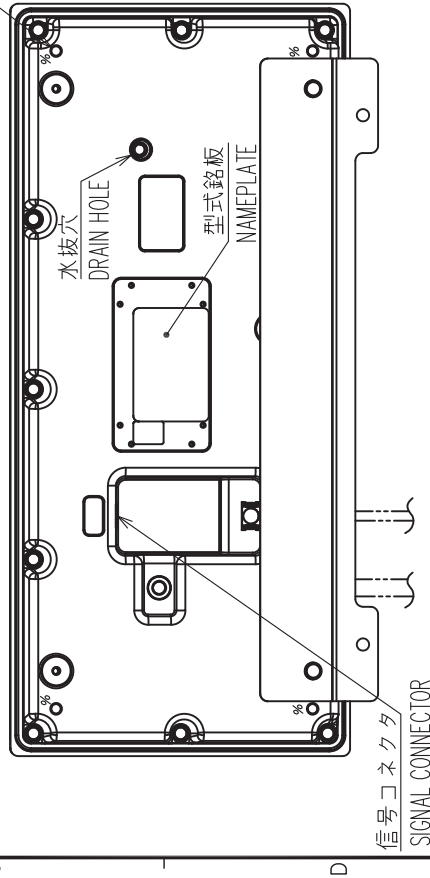
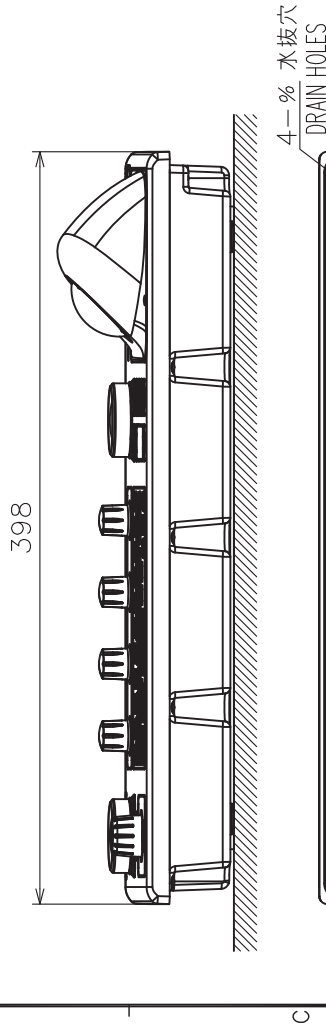
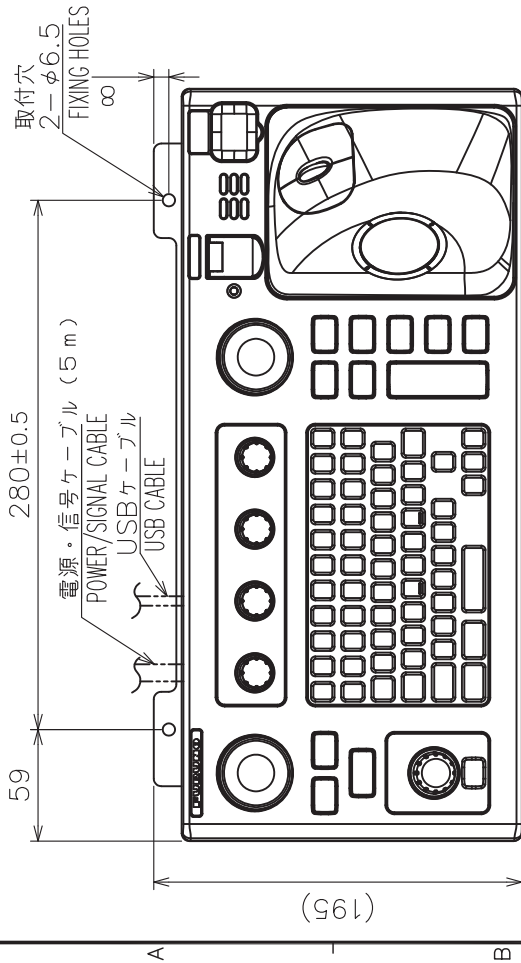
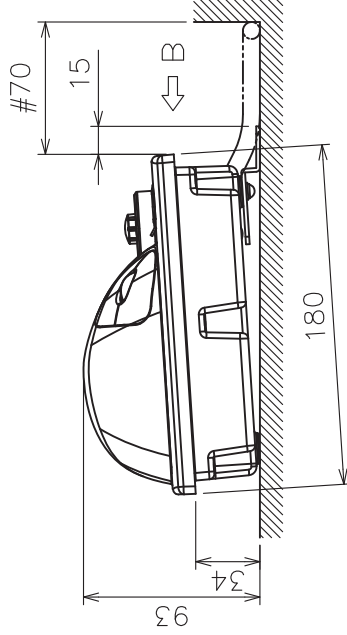
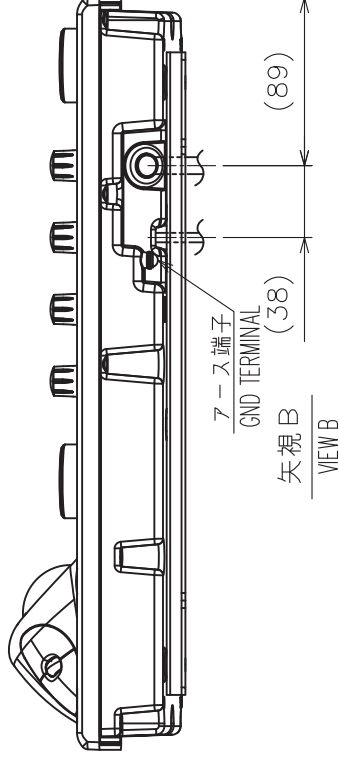

注記 1) 指定外の寸法公差は表1による。

2) #印寸法は最小サービスインスペーシングとする。

3) 取付ネジはトラスタップピンネジ<sup>®</sup>呼び径5×20を使用のこと。

NOTE 1. TABLE 1 INDICATES TOLERANCE OF DIMENSIONS WHICH IS NOT SPECIFIED.

2. # MINIMUM SERVICE CLEARANCE.

3. USE TAPPING SCREWS φ5x20 FOR FIXING THE UNIT.

DRAWN	5/Nov/2012	T. YAMASAKI	TITLE	RCU-024
CHECKED	5/Nov/2012	H. MAKI	名称	ECDIS操作部 (取付金具)
APPROVED	7/Nov/2012	Y. NISHIYAMA	外寸図	
SCALE	1/4	質量は5mケーブルを含む。 ±0% 質量は5mケーブルを含む。 ±0% MASS INCLUDES 5m CABLE.	NAME	ECDIS CONTROL UNIT (FIXTURE MOUNT)
DWG.No.	C4473-G04-B	REF.No.	24-014-120G-2	OUTLINE DRAWING

表1 TABLE 1

寸法区分 (mm) DIMENSION	公差 (mm) TOLERANCE
L ≤ 50	±1.5
50 < L ≤ 100	±2.5
100 < L ≤ 500	±3

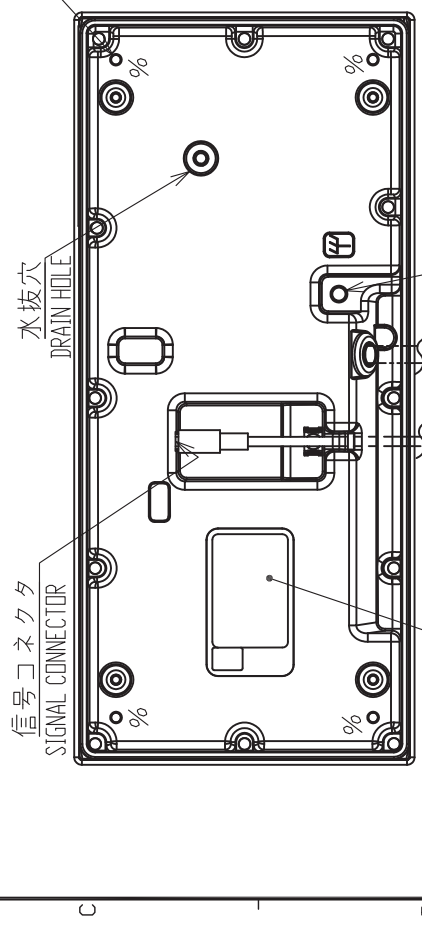
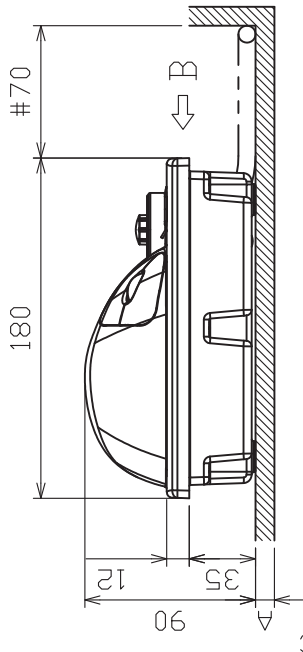
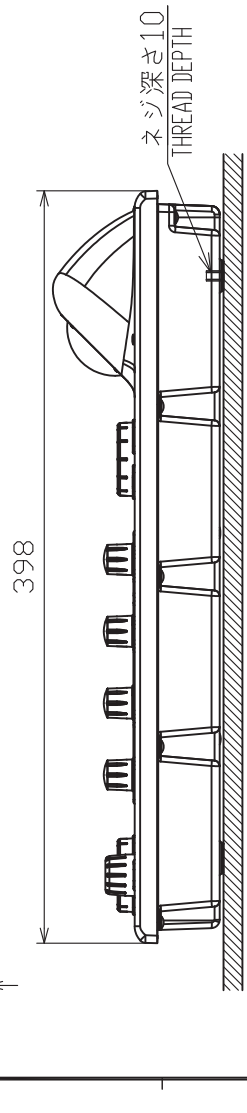
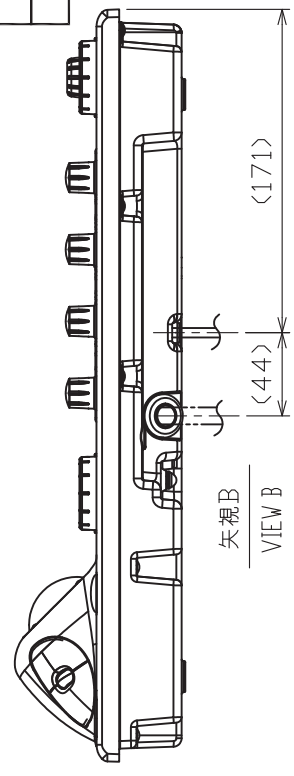
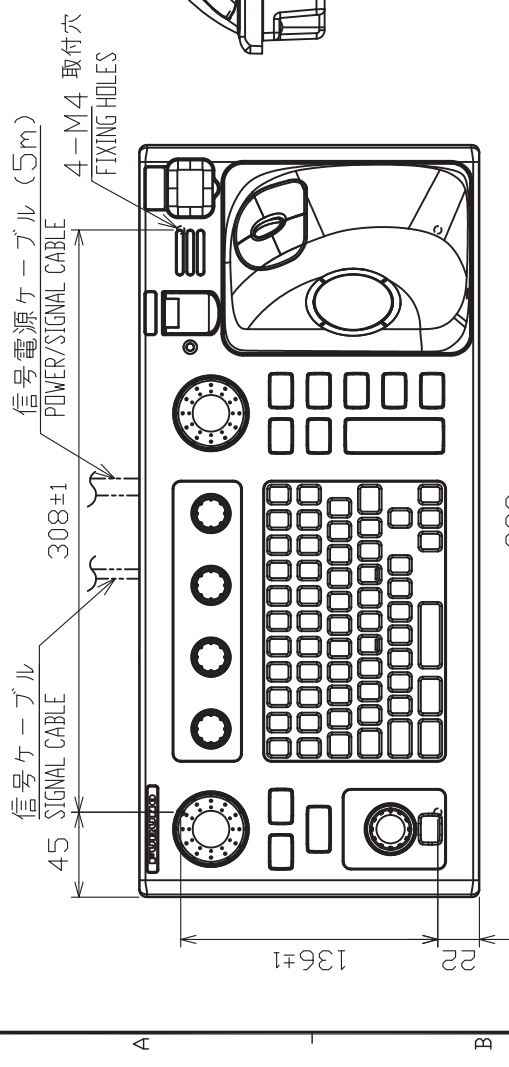

- 注記
- 1) 指定外の寸法公差は表1による。
  - 2) #印寸法は最小サービス空間寸法とする。
  - 3) 取付ネジはセムスネジB M4×12を使用のこと。  
壁の厚さ(A)は最小2mm、最大4mmとする。  
または、ネジ長さをA+8±2とする。

- NOTE
1. TABLE 1 INDICATES TOLERANCE OF DIMENSIONS WHICH IS NOT SPECIFIED.
  2. # MINIMUM SERVICE CLEARANCE.
  3. USE SEMS B SCREWS (M4x12) FOR BULKHEAD THICKNESS(A); 2 ≤ A ≤ 4 OR SCREW LENGTH: A+8±2.

DRAWN	10/Jan/2018	I.YAMASAKI	TITLE	RCU-024
CHECKED	10/Jan/2018	H.MAKI	名称	EC-DIS 操作部 (卓上装備)
APPROVED	11/Jan/2018	H.MAKI		外寸図
SCALE	1/4	100% 質量は5mケーブルを含む。 100% MASS INCLUDES 5m CABLE.	NAME	EC-DIS CONTROL UNIT (TABLETOP MOUNT)
DWG.No.	C4473-G19-A	REF.No.	24-014-510G-1	OUTLINE DRAWING

信号ケーブル  
SIGNAL CABLE

信号電源ケーブル (5m)  
POWER/SIGNAL CABLE

表1 TABLE 1

寸法区分 (mm) DIMENSION	公差 (mm) TOLERANCE
$L \leq 50$	$\pm 1.5$
$50 < L \leq 100$	$\pm 2.5$
$100 < L \leq 500$	$\pm 3$

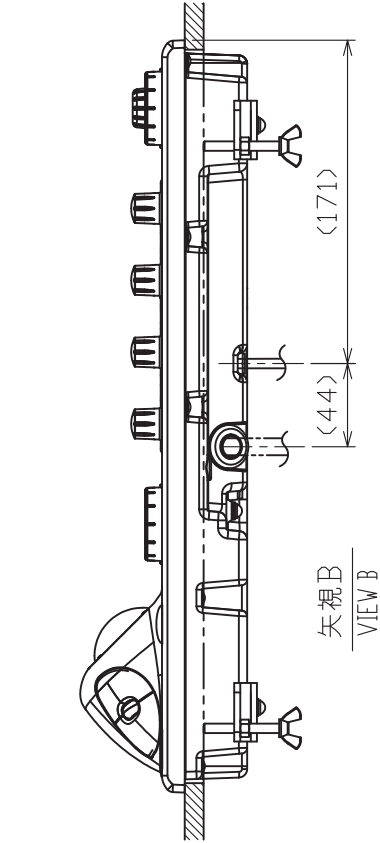

矢視 B  
VIEW B

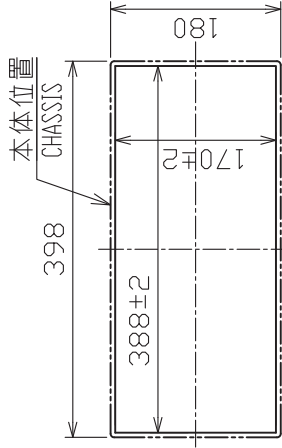
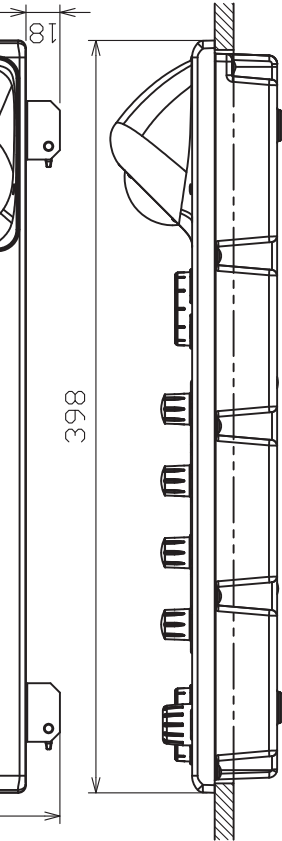

4-水抜穴 (%)  
DRAIN HOLES

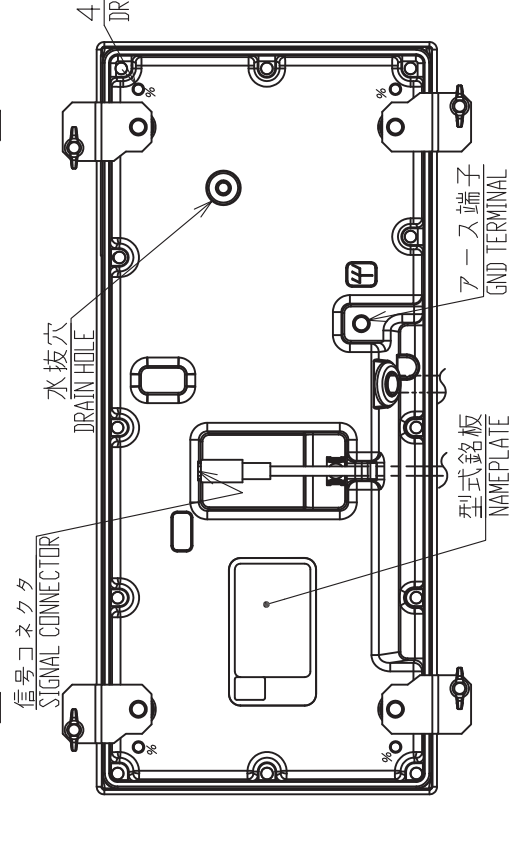

取付穴寸法 (尺度: 1/8)  
CUTOUT DIMENSIONS (SCALE: 1/8)

- 注記 1) 指定外の寸法公差は表 1 による。  
2) # 印寸法は最小サービス空間寸法とする。  
3) 壁の厚さ (A) は最小10mm、最大20mmとする。
- NOTE 1. TABLE 1 INDICATES TOLERANCE OF DIMENSIONS WHICH IS NOT SPECIFIED.  
2. # MINIMUM SERVICE CLEARANCE.  
3. BULKHEAD THICKNESS(A):  $10 \leq A \leq 20$ .

DRAWN	10/Jan/2018	I.YAMASAKI	TITLE	RCU-024
CHECKED	10/Jan/2018	H.MAKI	名称	EC DIS 操作部 (埋込装備)
APPROVED	11/Jan/2018	H.MAKI	外寸図	
SCALE	1/4	質量 2.3 kg 寸法 10% 質量は5mケーブルを含む。 MASS INCLUDES 5m CABLE.	NAME	EC DIS CONTROL UNIT (FLUSH MOUNT)
IMG No.	C4473-G18-A	REF.No.	24-014-500G-1	OUTLINE DRAWING

表1 TABLE 1

寸法区分 (mm) DIMENSION	公差 (mm) TOLERANCE
L ≤ 50	±1.5
50 < L ≤ 100	±2.5
100 < L ≤ 500	±3

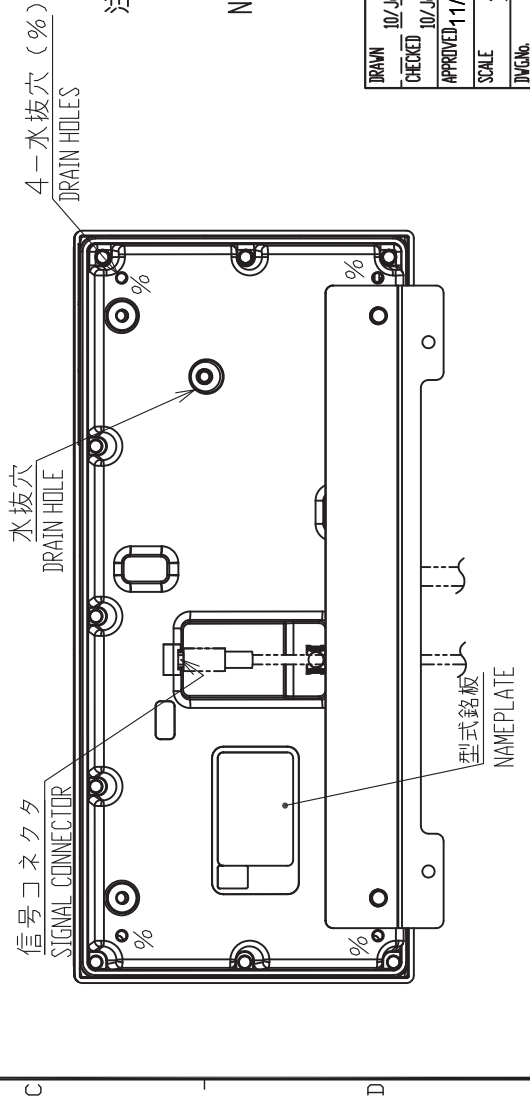
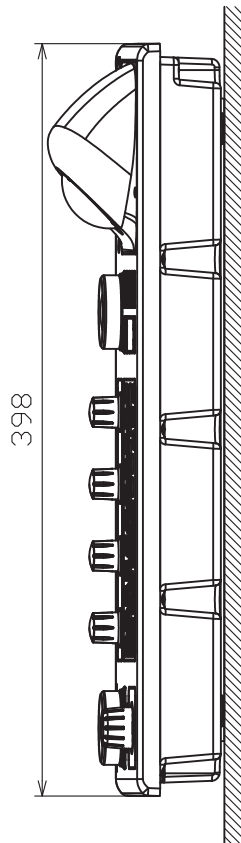
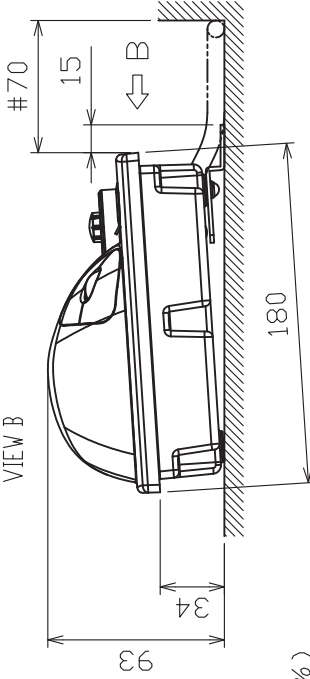
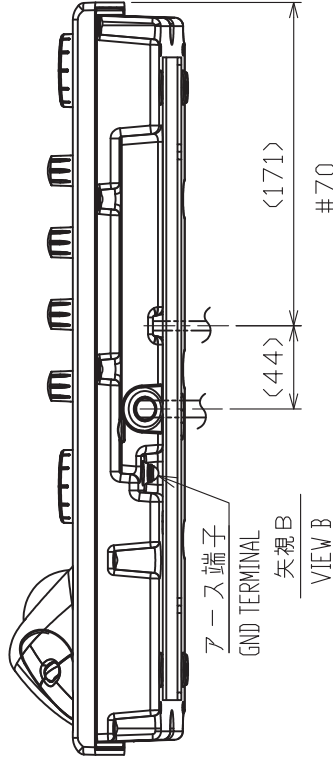
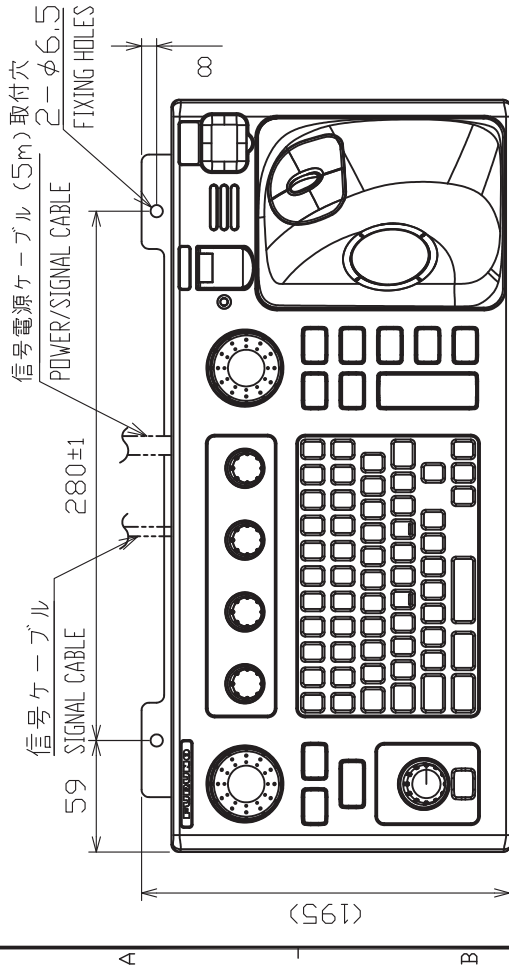

- 注記 1) 指定外の寸法公差は表 1 による。  
 2) # 印寸法は最小サービス空間寸法とする。  
 3) 壁の厚さ (A) は最小10mm、最大20mmとする。
- NOTE 1. TABLE 1 INDICATES TOLERANCE OF DIMENSIONS WHICH IS NOT SPECIFIED.  
 2. # MINIMUM SERVICE CLEARANCE.  
 3. BULKHEAD THICKNESS(A): 10 ≤ A ≤ 20.

DRAWN	10/Jan/2018	I.YAMASAKI	TITLE	RCU-024
CHECKED	10/Jan/2018	H.MAKI	名称	EC DIS 操作部 (取付金具)
APPROVED	11/Jan/2018	H.MAKI	外寸図	
SCALE	1/4	W/S 2.4	W/M	EC DIS CONTROL UNIT (FIXTURE MOUNT)
IMG No.	C4473-020-A	REF.No.	24-014-520G-1	OUTLINE DRAWING



表1 TABLE 1

寸法区分 (mm) DIMENSION	公差 (mm) TOLERANCE
L ≤ 50	±1.5
50 < L ≤ 100	±2.5
100 < L ≤ 500	±3



4-水抜穴 (一部)  
DRAIN HOLES

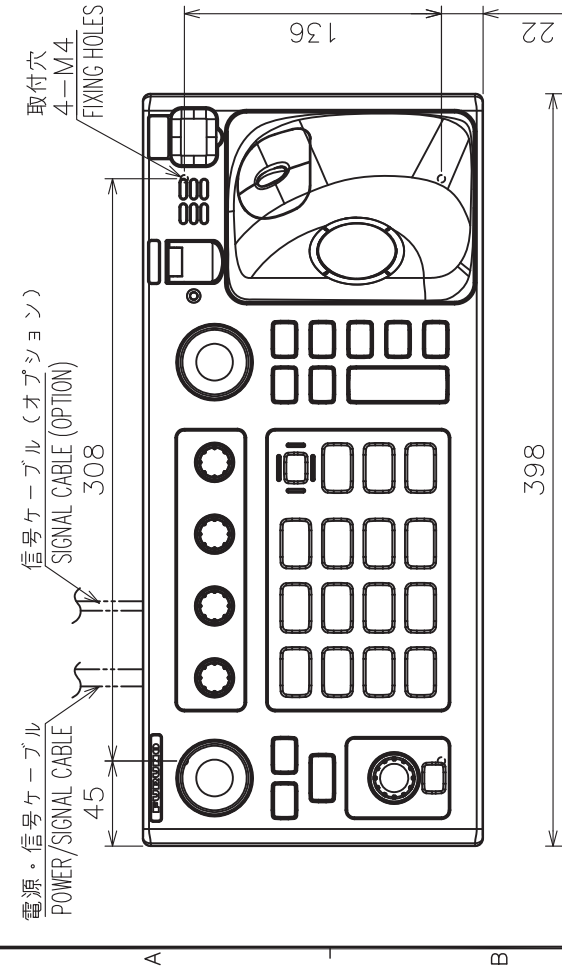
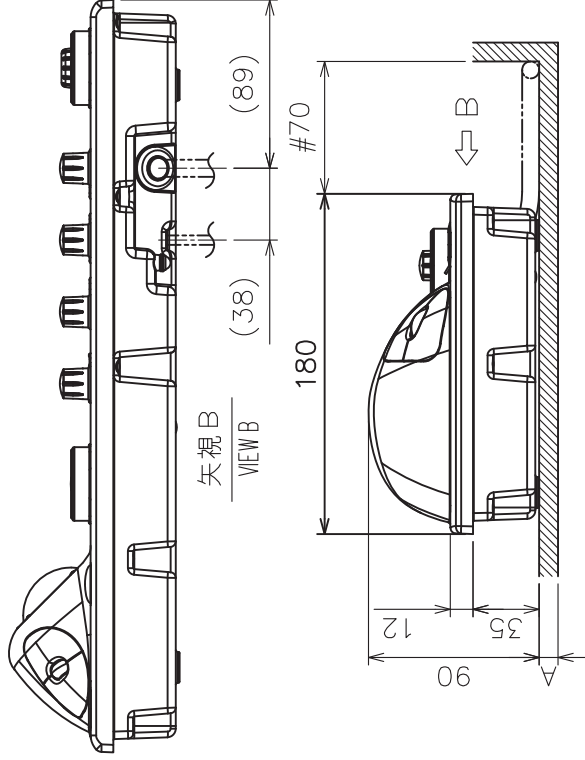
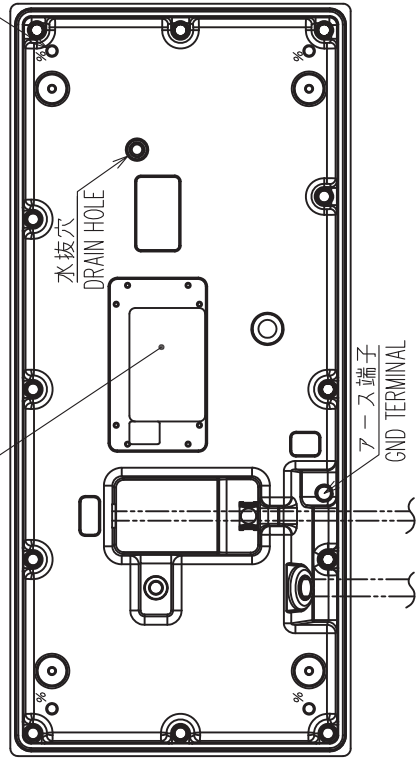

- 注 記
- 1) 指定外の寸法公差は表 1 による。
  - 2) # 印寸法は最小サービス空間寸法とする。
  - 3) 取付ネジはセムスネジ B M4 × 1.2 を使用のこと。  
壁の厚さ (A) は最小 2、最大 4 とする。  
または、ねじ長さを (A + 8 ± 2) とする。
- NOTE
1. TABLE 1 INDICATES TOLERANCE OF DIMENSIONS WHICH IS NOT SPECIFIED.
  2. #: MINIMUM SERVICE CLEARANCE.
  3. USE SEMS B SCREWS M4×1.2 FOR FIXING THE UNIT.  
BULKHEAD THICKNESS (A): 2 ≤ A ≤ 4 OR SCREW LENGTH: A+8±2.

DRAWN	21/May/2012	T.YAMASAKI	TITLE	RCU-025	
CHECKED	21/May/2012	H.MAKI	名称	レーダー操作部 (卓上装備)	
APPROVED	24/May/2012	Y.NISHIYAMA	外寸図		
SCALE	1/4	MASS 3.0	質量は 5mm ケーブルを含む。 MASS INCLUDES 5m CABLE.	NAME	RADAR CONTROL UNIT (TABLETOP MOUNT)
DWG.No.	C3607-G01-A	REF.No.	03-179-100G-2	OUTLINE DRAWING	



電源・信号ケーブル  
POWER/SIGNAL CABLE

信号ケーブル (オプション)  
SIGNAL CABLE (OPTION)



表1 TABLE 1

寸法区分 (mm) DIMENSION	公差 (mm) TOLERANCE
L ≤ 50	±1.5
50 < L ≤ 100	±2.5
100 < L ≤ 500	±3

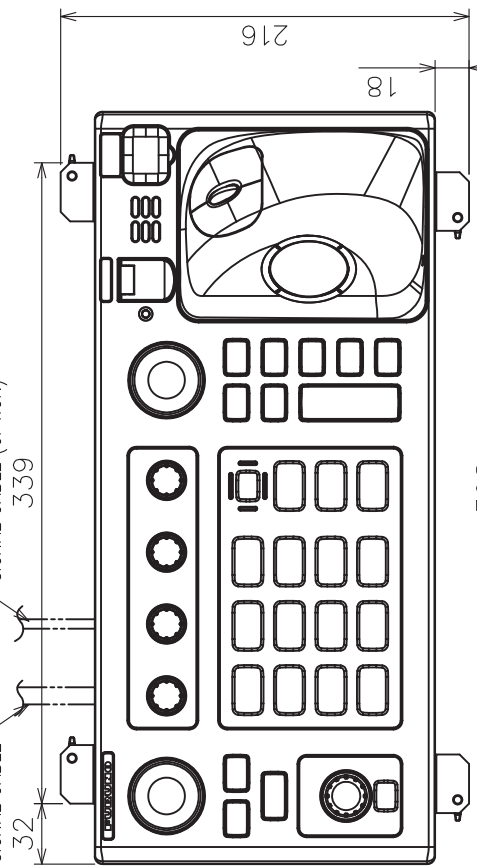
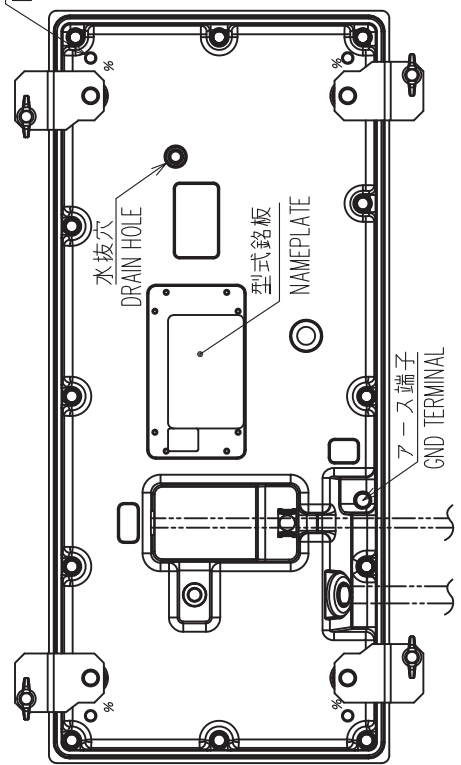
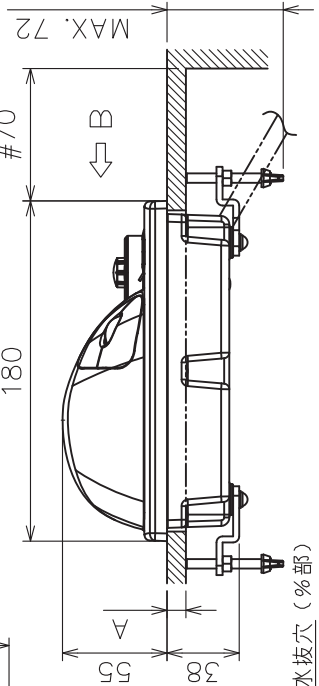
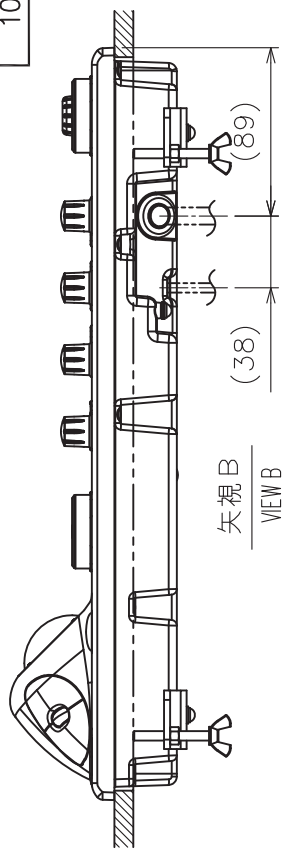

- 注記
- 1) 指定外の寸法公差は表1による。
  - 2) #印寸法は最小サービス空間寸法とする。
  - 3) 壁の厚さ(A)は最小10、最大20とする。

- NOTE
1. TABLE 1 INDICATES TOLERANCE OF DIMENSIONS WHICH IS NOT SPECIFIED.
  2. #: MINIMUM SERVICE CLEARANCE.
  3. BULKHEAD THICKNESS (A): 10 ≤ A ≤ 20.

DRAWN	21/May/2012 T.YAMASAKI	TITLE	RCU-025
CHECKED	21/May/2012 H.MAKI	名称	レーダー操作部 (埋込装備)
APPROVED	24/May/2012 Y.NISHIYAMA	外寸図	
SCALE	1/4 MASS 3.1	名称	RADAR CONTROL UNIT (FLUSH MOUNT)
DWG.No.	C3607-G02-A	REF.No.	03-179-110G-2

FCR-2819 ser.  
±0.04質量は5mmケーブルを含む。  
MASS INCLUDES 5m CABLE.

表1 TABLE 1

寸法区分 (mm) DIMENSION	公差 (mm) TOLERANCE
L ≤ 50	±1.5
50 < L ≤ 100	±2.5
100 < L ≤ 500	±3

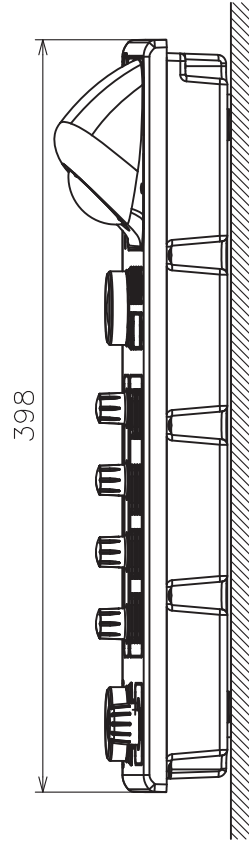
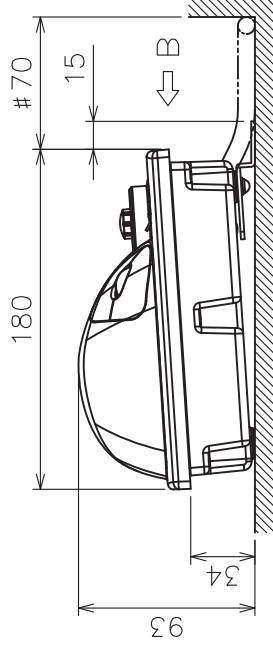
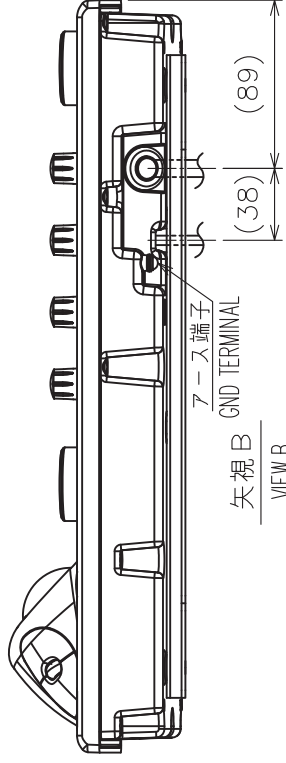
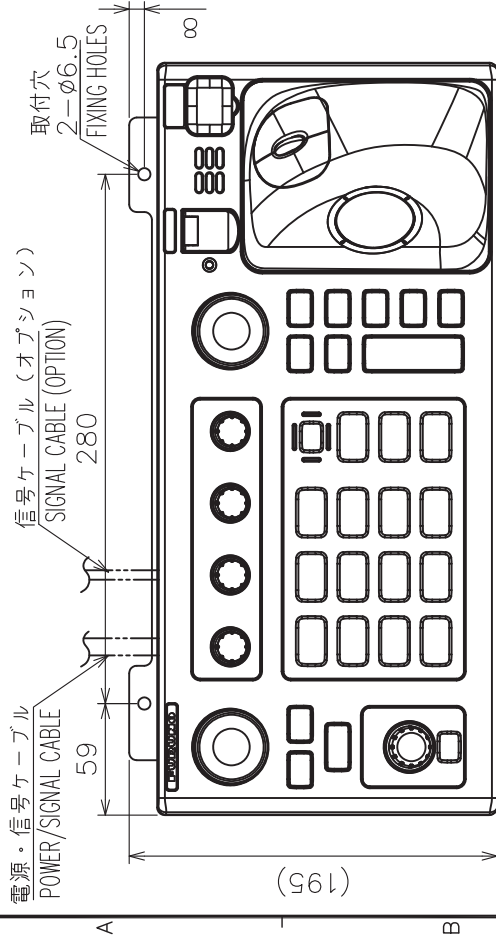

4-水抜穴 (一部)  
DRAIN HOLES

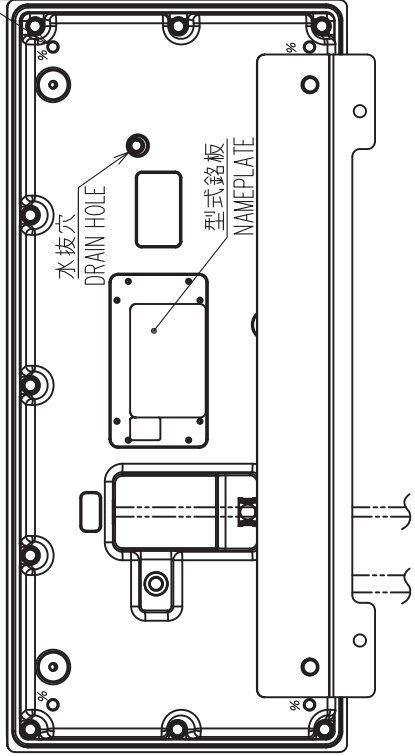

- 注 記
- 1) 指定外の寸法公差は表1による。
  - 2) #印寸法は最小サージ空間寸法とする。
  - 3) 取付ネジはトラスターピンネジ<sup>®</sup>呼び径5×20を使用のこと。

- NOTE
1. TABLE 1 INDICATES TOLERANCE OF DIMENSIONS WHICH IS NOT SPECIFIED.
  2. #: MINIMUM SERVICE CLEARANCE.
  3. USE TAPPING SCREWS  $\phi 5 \times 20$  FOR FIXING THE UNIT.

DRAWN	21/May/2012 I.YAMASAKI	TITLE	RCU-025
CHECKED	21/May/2012 H.MAKI	名称	レーダー操作部 (取付金具)
APPROVED	24/May/2012 Y.NISHIYAMA	外寸図	
SCALE	1/4 MASS 3.3 kg	FOR-2819 ser.	
DWG.No.	C3607-G03-A	質量は5mmケーブルを含む。 MASS INCLUDES 5m CABLE.	
		REF.No.	03-179-120G-2
		NAME	RADAR CONTROL UNIT (FIXTURE MOUNT)
		OUTLINE DRAWING	



表1 TABLE 1

寸法区分 (mm) DIMENSION	公差 (mm) TOLERANCE
L ≤ 50	±1.5
50 < L ≤ 100	±2.5
100 < L ≤ 500	±3

注記 1) 指定外の寸法公差は表1による。  
 2) #印寸法は最小サービス空間寸法とする。  
 3) 取付ネジはセムスネジB M4×12を使用のこと。  
 壁の厚さ(A)は最小2、最大4とする。  
 または、ねじ長さを(A+8±2)とする。

NOTE 1. TABLE 1 INDICATES TOLERANCE OF DIMENSIONS WHICH IS NOT SPECIFIED.  
 2. # MINIMUM SERVICE CLEARANCE.  
 3. USE SEMS B SCREWS M4×12 FOR FIXING THE UNIT.  
 BULKHEAD THICKNESS (A): 2 ≤ A ≤ 4 OR SCREW LENGTH: A+8±2.

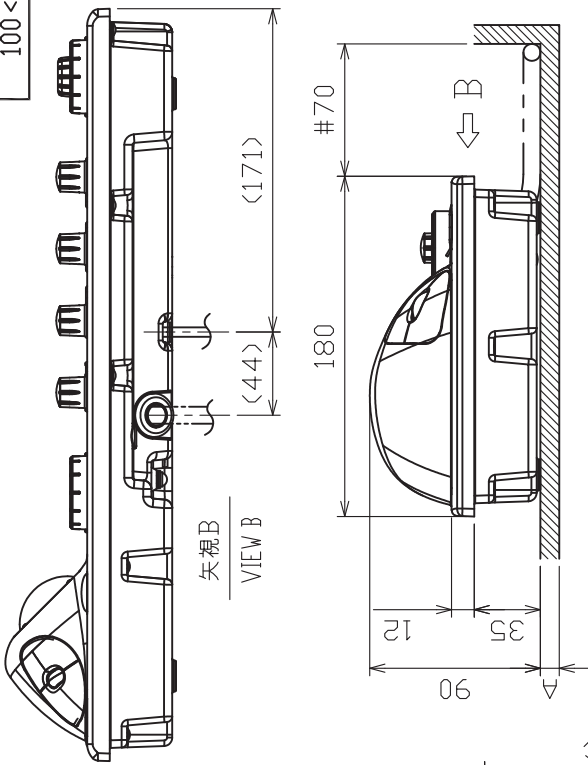
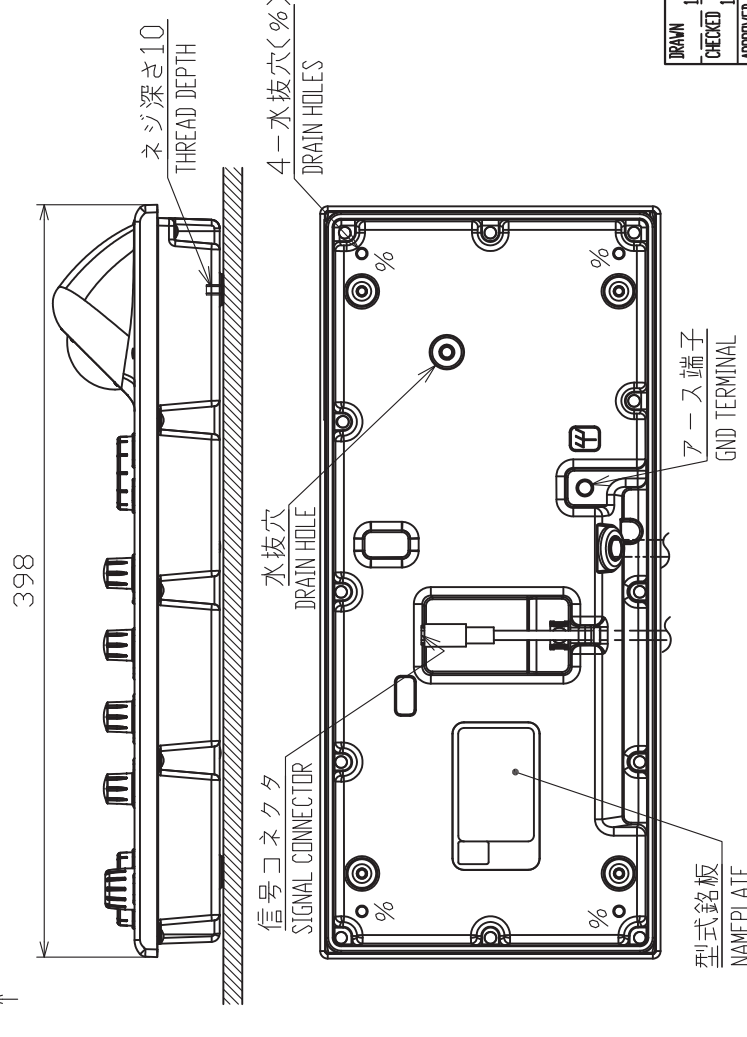
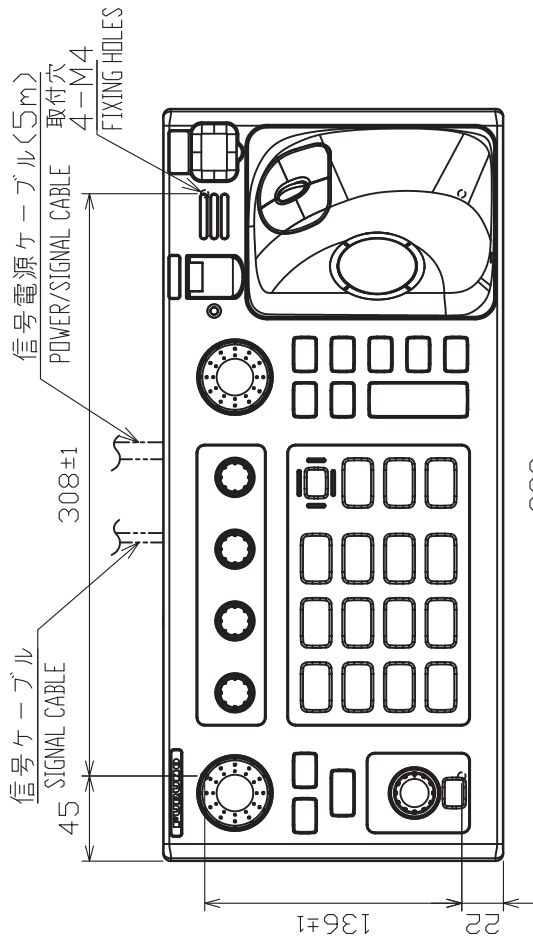
DRAWN	11/Jan/2018	I.YAMASAKI	TITLE	RCU-025
CHECKED	11/Jan/2018	H.MAKI	名称	レーダー操作部(卓上装備)
APPROVED	11/Jan/2018	H.MAKI	外寸図	
SCALE	1/4	WSS 2.1	WME	RADAR CONTROL UNIT (TABLETOP MOUNT)
FIG.No.	C3607-605-A	03-179-200G-0	REF.No.	OUTLINE DRAWING

表1 TABLE 1

寸法区分 (mm) DIMENSION	公差 (mm) TOLERANCE
L ≤ 50	±1.5
50 < L ≤ 100	±2.5
100 < L ≤ 500	±3

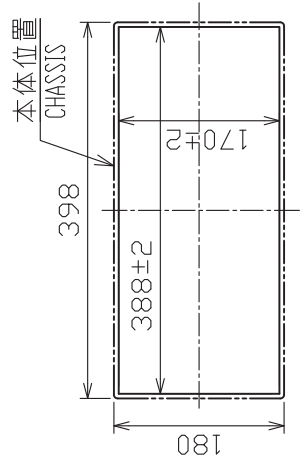
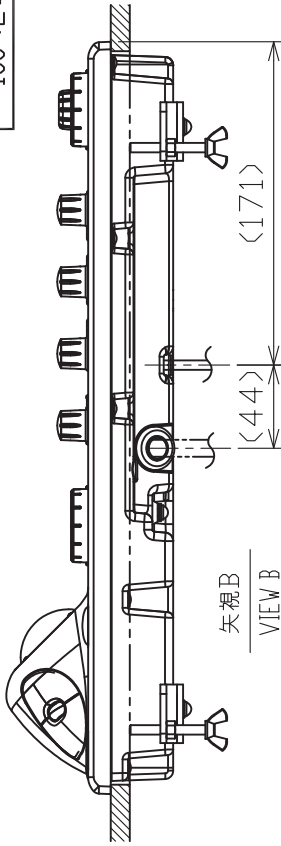
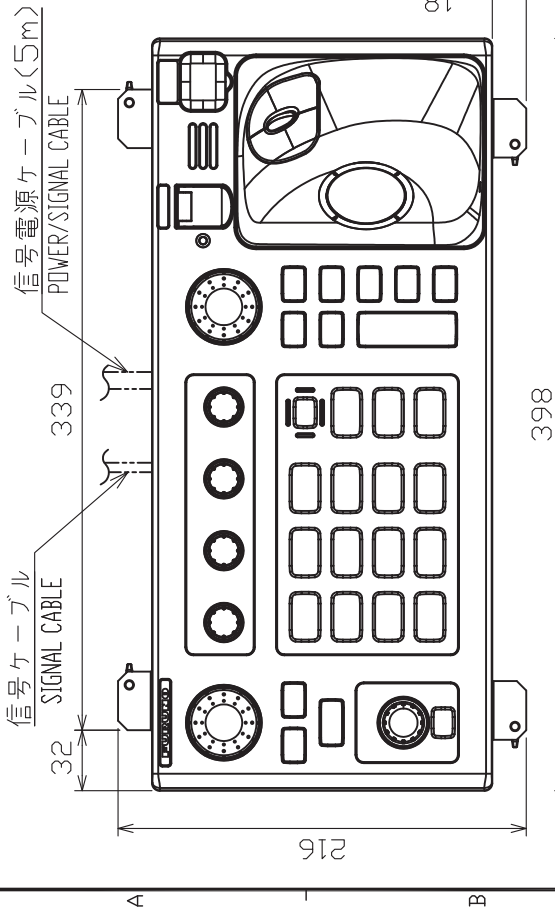

取付寸法 (尺度: 1/8)  
CUTOUT DIMENSIONS (SCALE: 1/8)

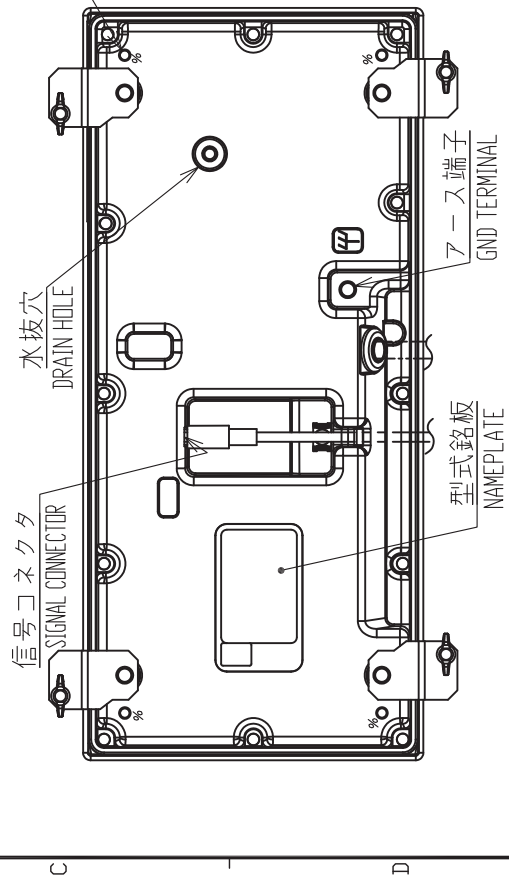
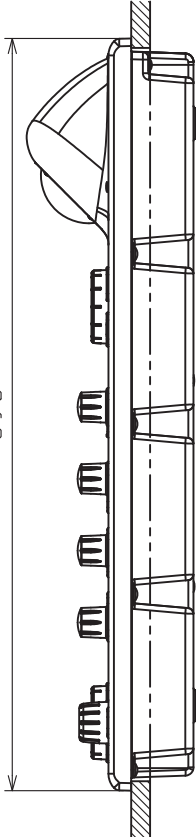
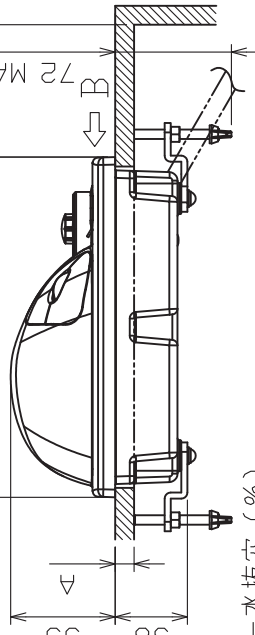

- 注記
- 1) 指定外の寸法公差は表1による。
  - 2) #印寸法は最小サービス空間寸法とする。
  - 3) 壁の厚さ(A)は最小10mm、最大20mmとする。

- NOTE
1. TABLE 1 INDICATES TOLERANCE OF DIMENSIONS WHICH IS NOT SPECIFIED.
  2. # MINIMUM SERVICE CLEARANCE.
  3. BULKHEAD THICKNESS(A): 10 ≤ A ≤ 20.

DRAWN	11/Jan/2018	I.YAMASAKI	TITLE	RCU-025
CHECKED	11/Jan/2018	H.MAKI	名称	レーダー操作部 (埋込装備)
APPROVED	11/Jan/2018	H.MAKI	外寸図	
SCALE	1/4	MASS 2.3 kg	W/M	RADAR CONTROL UNIT (FLUSH MOUNT)
IMG.No.	C3607-606-A	REF.No.	03-179-210G-0	OUTLINE DRAWING

表1 TABLE 1

寸法区分 (mm) DIMENSION	公差 (mm) TOLERANCE
L ≤ 50	±1.5
50 < L ≤ 100	±2.5
100 < L ≤ 500	±3

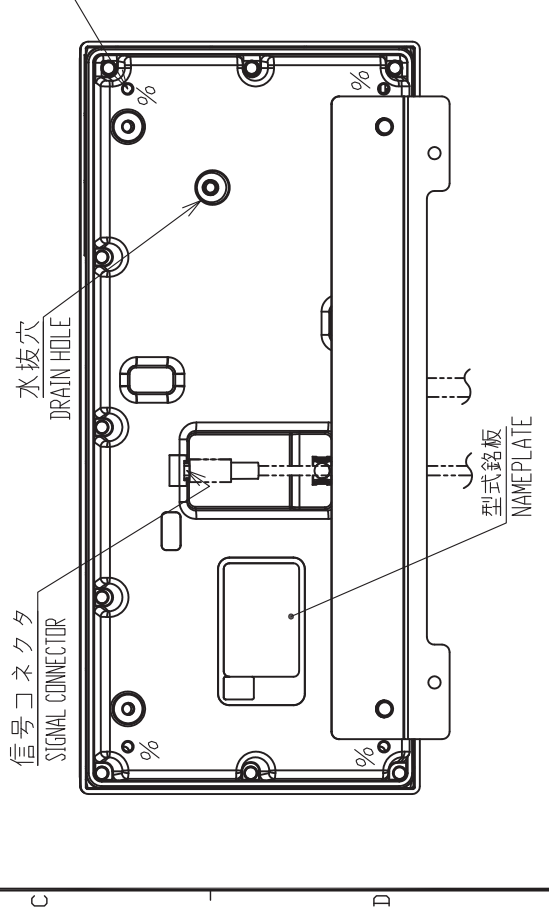
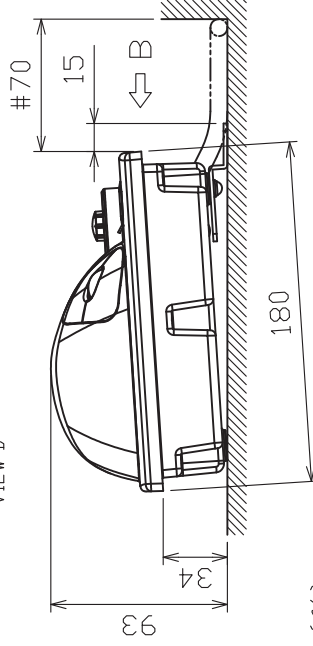
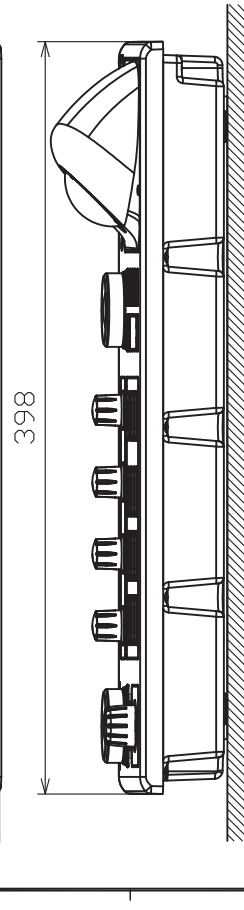
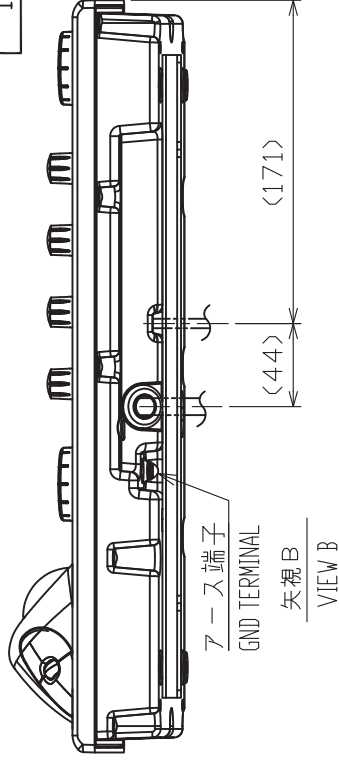
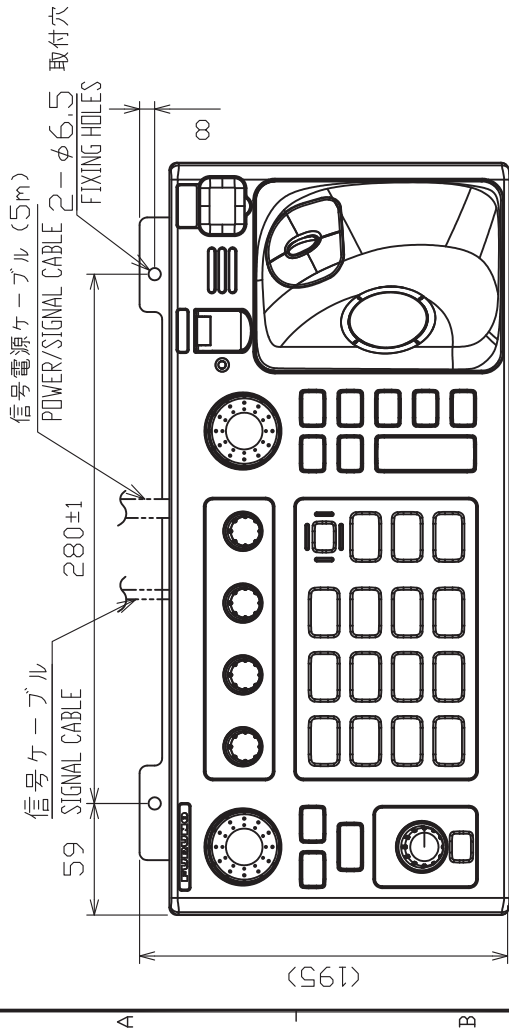

- 注記
- 1) 指定外の寸法公差は表1による。
  - 2) #印寸法は最小サービス空間寸法とする。
  - 3) 壁の厚さ(A)は最小10mm、最大20mmとする。
- NOTE
1. TABLE 1 INDICATES TOLERANCE OF DIMENSIONS WHICH IS NOT SPECIFIED.
  2. # MINIMUM SERVICE CLEARANCE.
  3. BULKHEAD THICKNESS(A): 10 ≤ A ≤ 20.

DRAWN	11/Jan/2018	I.YAMASAKI	TITLE	RCU-025
CHECKED	11/Jan/2018	H.MAKI	名称	レーダー操作部(取付金具)
APPROVED	11/Jan/2018	H.MAKI	外寸図	
SCALE	1/4	100% 質量は5mケーブルを含む。 MATERIAL MASS INCLUDES 5m CABLE.	NAME	RADAR CONTROL UNIT (FIXTURE MOUNT)
IMG.No.	C3607-607-A	REF.No.	03-179-220G-0	OUTLINE DRAWING



表1 TABLE 1

寸法区分 (mm) DIMENSION	公差 (mm) TOLERANCE
L ≤ 50	±1.5
50 < L ≤ 100	±2.5
100 < L ≤ 500	±3

- 注記 1) 指定外の寸法公差は表1による。  
 2) #印寸法は最小サービス空間寸法とする。  
 3) 取付ネジはセムスネジB M3×1.2を使用のこと。壁の厚さ(A)は最小2、最大4とする。それ以外はねじ長さをA+8±2とする。
- NOTE 1. TABLE 1 INDICATES TOLERANCE OF DIMENSIONS WHICH IS NOT SPECIFIED.  
 2. # MINIMUM SERVICE CLEARANCE.  
 3. USE SEMS B SCREWS M3x1.2 FOR BULKHEAD THICKNESS (A): 2 ≤ A ≤ 4. OR SCREW LENGTH: A+8±2.

DRAWN	5/Nov/2012	T. YAMASAKI	TITLE	RCU-026
CHECKED	5/Nov/2012	H. MAKI	名称	トラックボール操作部 (卓上装備)
APPROVED	7/Nov/2012	Y. NISHIYAMA	外寸図	
SCALE	1/2	質量 1.4 kg 質量は5mケーブルを含む。 MASS INCLUDES 5m CABLE.	NAME	TRACKBALL CONTROL UNIT (TABLETOP MOUNT)
DWG.No.	C4473-G05-B	REF.No.	24-014-150G-2	OUTLINE DRAWING

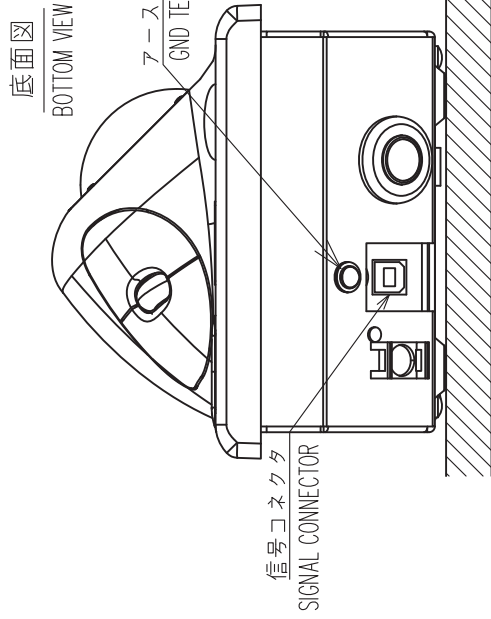
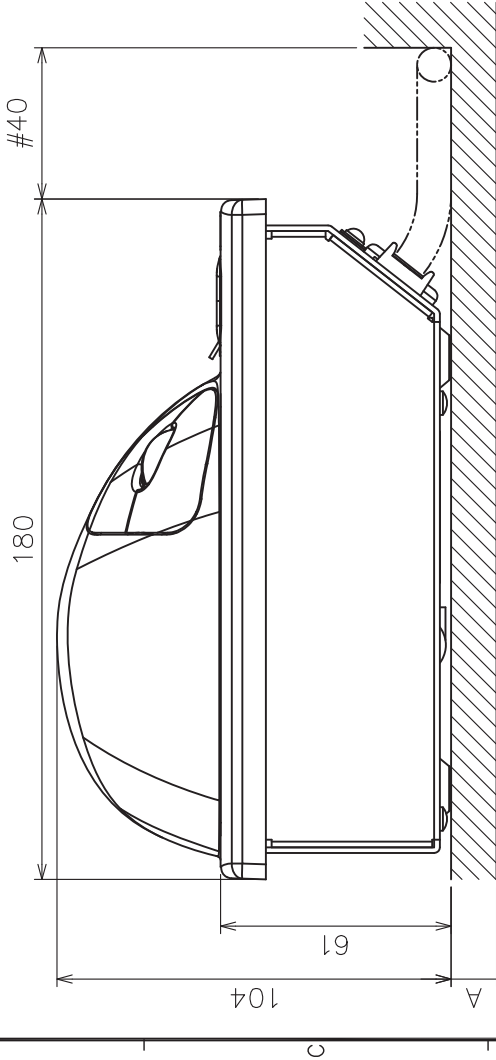
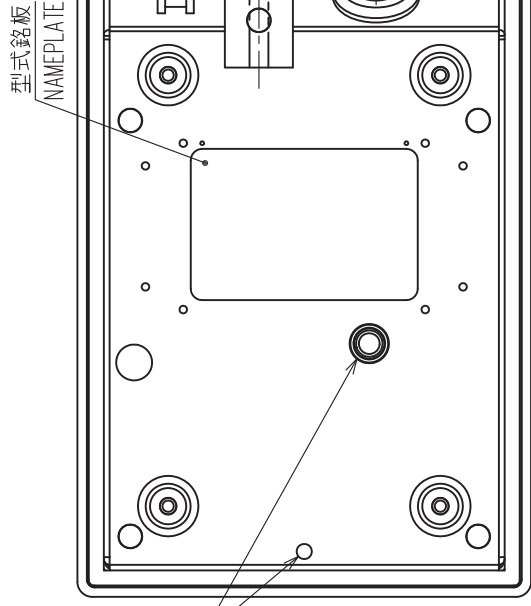
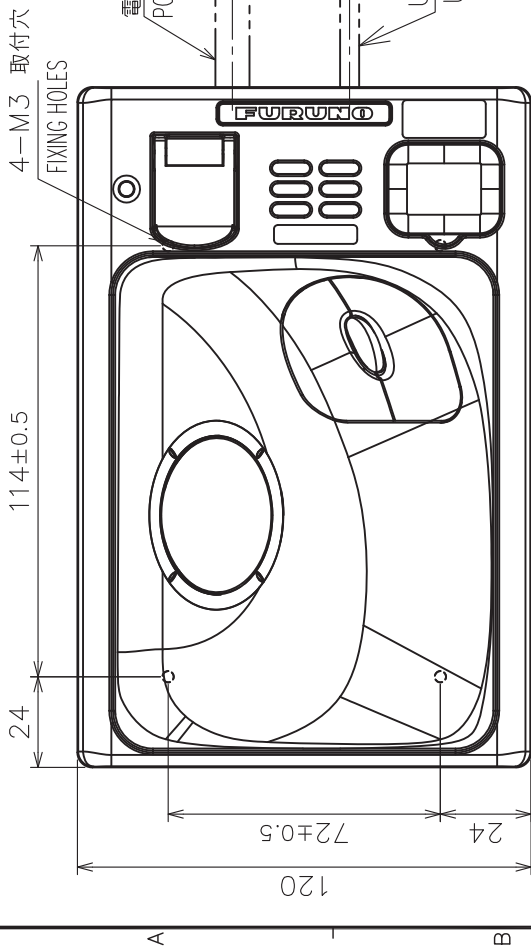

表1 TABLE 1

寸法区分 (mm) DIMENSION	公差 (mm) TOLERANCE
L ≤ 50	±1.5
50 < L ≤ 100	±2.5
100 < L ≤ 500	±3

取付穴寸法 (尺度: 1/4)  
CUTOUT DIMENSIONS (SCALE: 1/4)

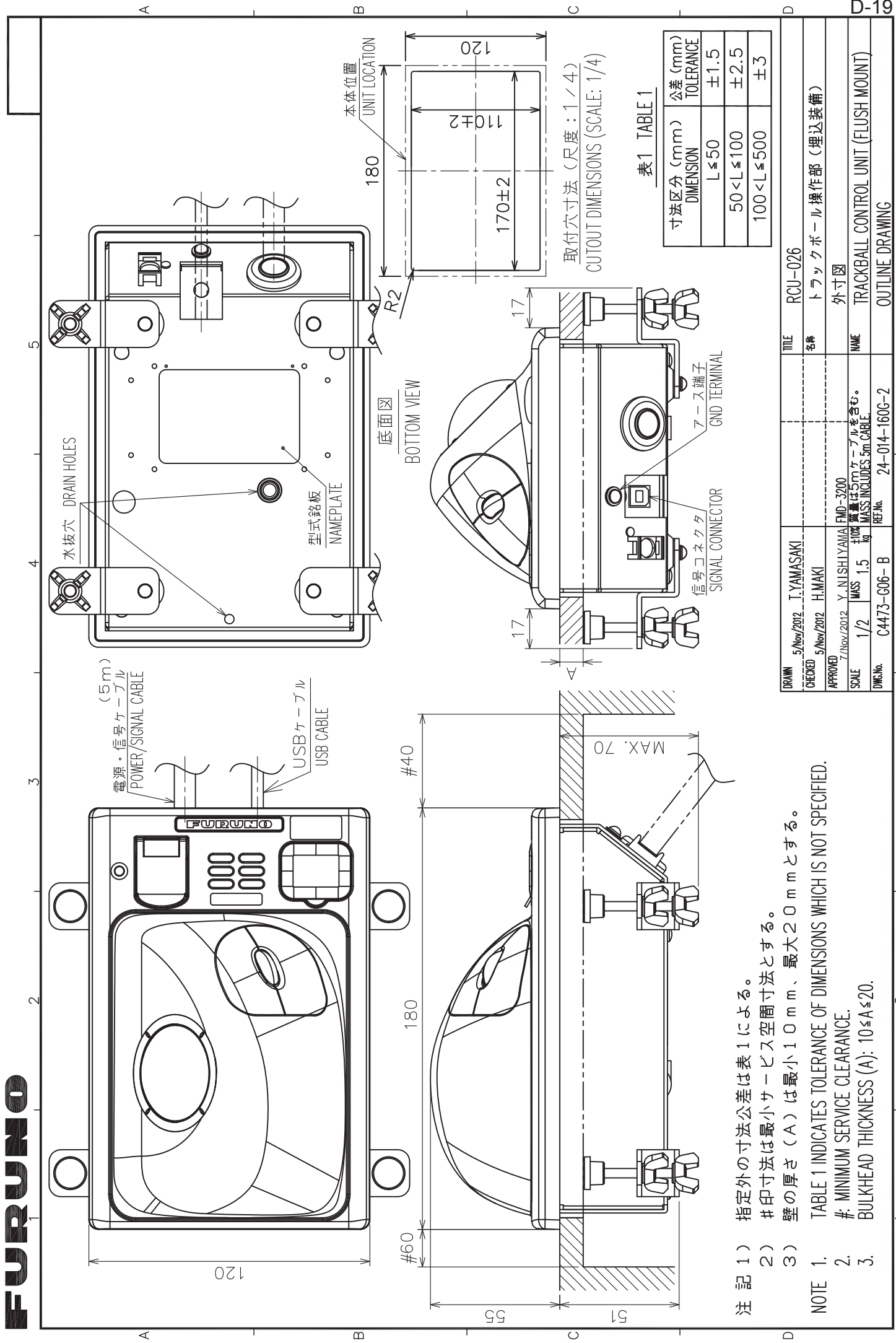
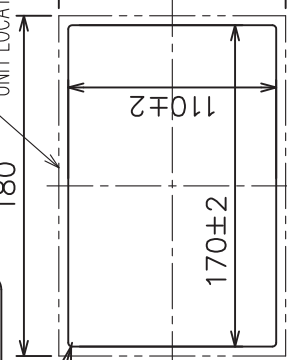

- 注記 1) 指定外の寸法公差は表1による。  
 2) #印寸法は最小サージス空間寸法とする。  
 3) 壁の厚さ(A)は最小10mm、最大20mmとする。
- NOTE 1. TABLE 1 INDICATES TOLERANCE OF DIMENSIONS WHICH IS NOT SPECIFIED.  
 2. #: MINIMUM SERVICE CLEARANCE.  
 3. BULKHEAD THICKNESS (A): 10 ≤ A ≤ 20.

DRAWN	5/Nov/2012	T.YAMASAKI	TITLE	RCU-026
CHECKED	5/Nov/2012	H.MAKI	名称	トラックボール操作部 (埋込装備)
APPROVED	7/Nov/2012	Y.NISHIYAMA	外寸図	
SCALE	1/2	質量 1.5 kg	NAME	TRACKBALL CONTROL UNIT (FLUSH MOUNT)
DMC.No.	C4473-G06-B	質量は5mケーブルを含む。 #104 MASS INCLUDES 5m CABLE.	REF.No.	24-014-160G-2
				OUTLINE DRAWING

2-φ6.5 取付穴  
FIXING HOLES

電源・信号ケーブル (5m)  
POWER/SIGNAL CABLE

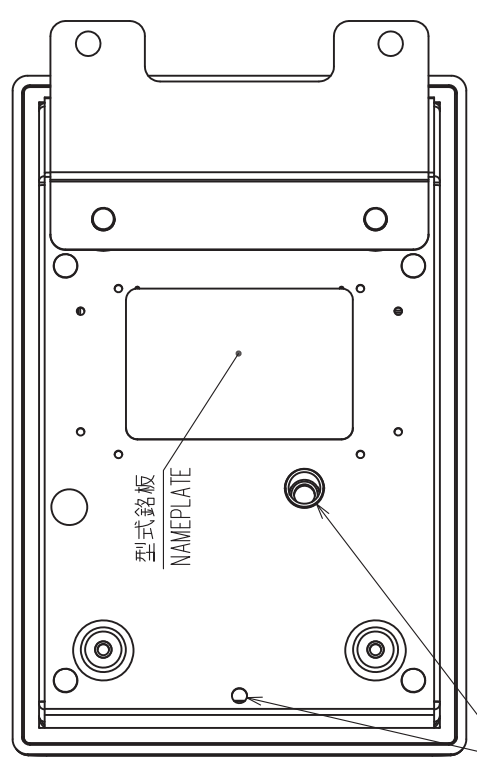

USBケーブル  
USB CABLE



表1 TABLE 1

寸法区分 (mm) DIMENSION	公差 (mm) TOLERANCE
L ≤ 50	±1.5
50 < L ≤ 100	±2.5
100 < L ≤ 500	±3

- 注 記
- 1) 指定外の寸法公差は表1による。
  - 2) #印寸法は最小サービスクリアランスとする。
  - 3) 取付ネジはトラスタツピンネジ呼び径5×20を使用のこと。
- NOTE
1. TABLE 1 INDICATES TOLERANCE OF DIMENSIONS WHICH IS NOT SPECIFIED.
  2. # MINIMUM SERVICE CLEARANCE.
  3. USE TAPPING SCREWS φ5x20 FOR FIXING THE UNIT.

DRAWN	5/Nov/2012	T.YAMASAKI	TITLE	RCU-026
CHECKED	5/Nov/2012	H.MAKI	名称	トラックボール操作部 (取付金具)
APPROVED	7/Nov/2012	Y.NISHIYAMA	外寸図	
SCALE	1/2	質量 1.5 kg #104質量は5mケーブルを含む。 #104 MASS INCLUDES 5m CABLE.	NAME	TRACKBALL CONTROL UNIT (FIXTURE MOUNT)
DWG.No.	C4473-G07-B	REF.No.	24-014-170G-2	OUTLINE DRAWING

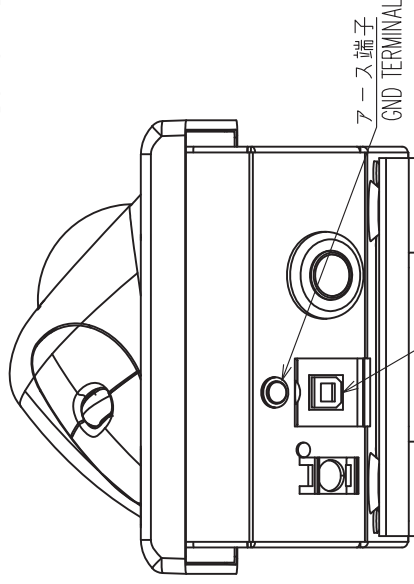
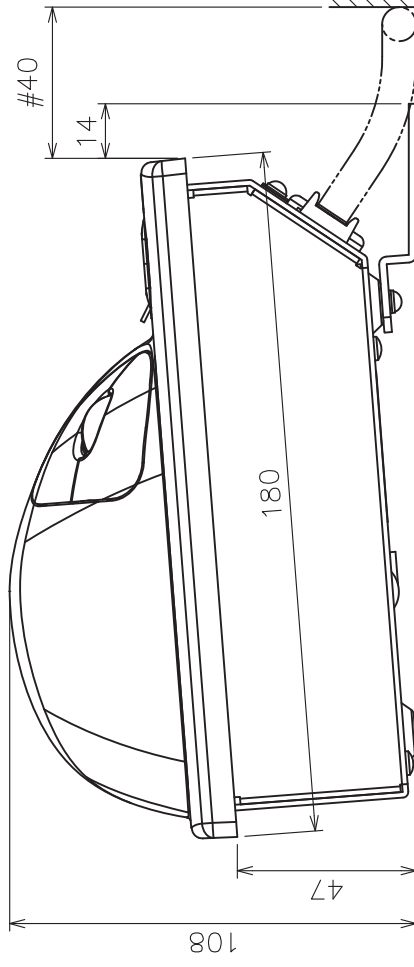
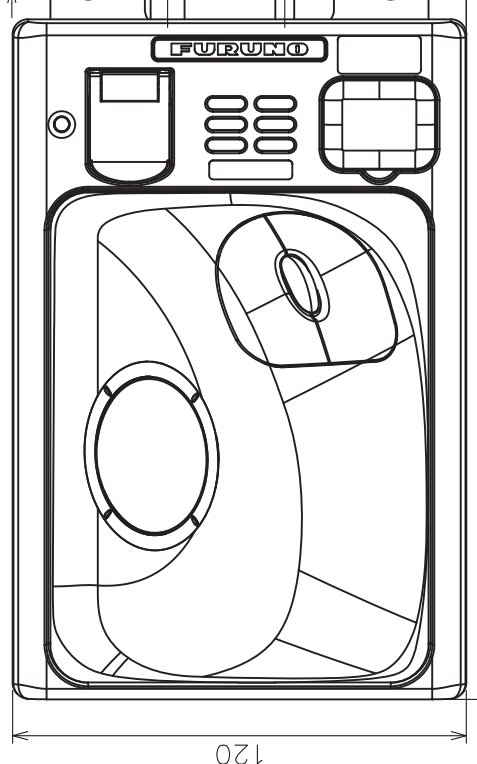

表 1 TABLE 1

寸法区分 (mm) DIMENSIONS	公差 (mm) TOLERANCE
$L \leq 50$	$\pm 1.5$
$50 < L \leq 100$	$\pm 2.5$
$100 < L \leq 500$	$\pm 3$

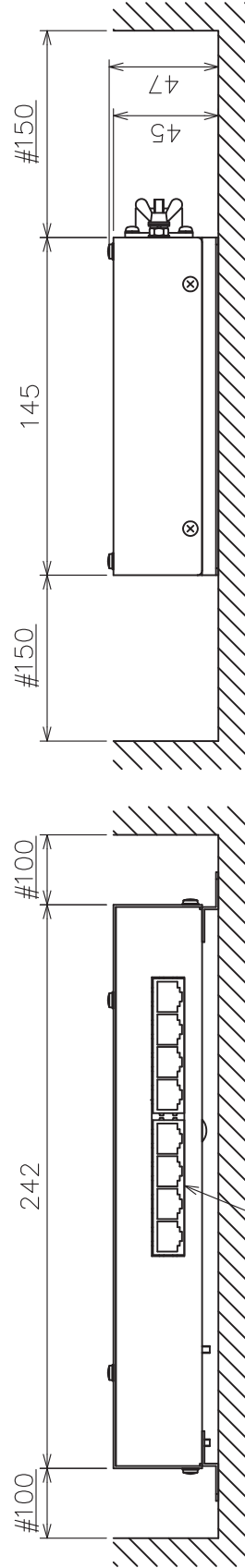
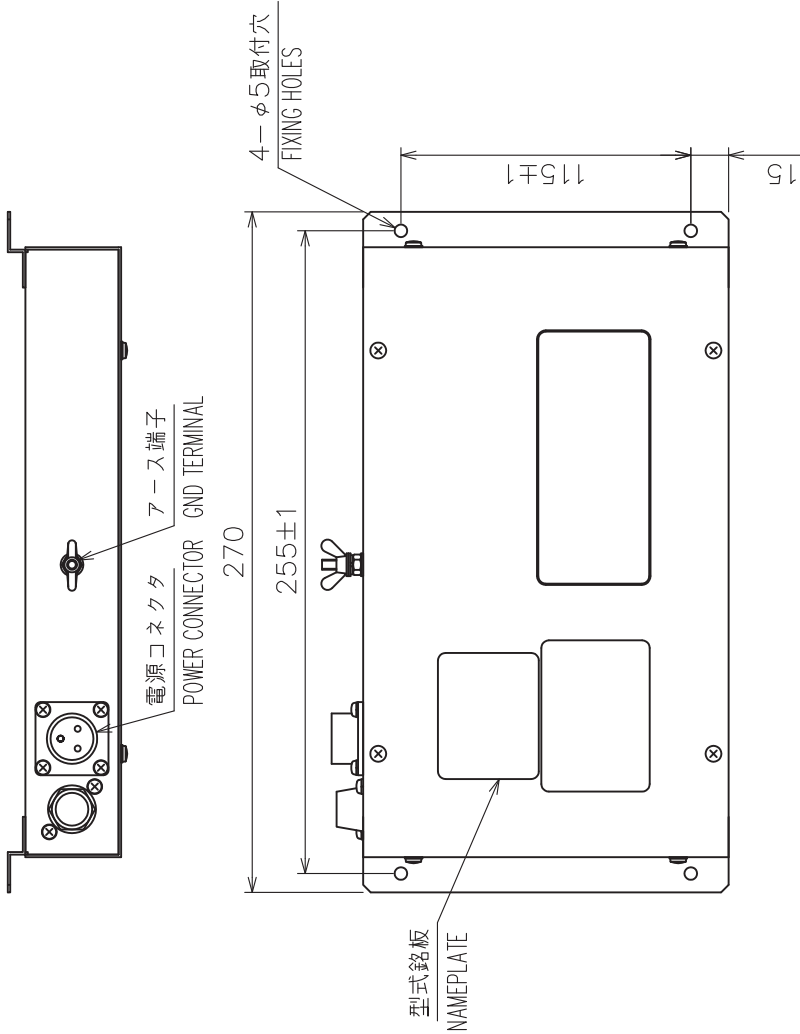

- 注 記
- 1) 指定外寸法公差は表 1 による
  - 2) # 印寸法は最小サービスクリアランスとする
  - 3) 取付用ネジはトラスタッピンネジ呼び径 4×1.6 を使用のこと
- NOTE
1. TABLE 1 INDICATES TOLERANCE OF DIMENSIONS WHICH IS NOT SPECIFIED.
  2. # MINIMUM SERVICE CLEARANCE.
  3. USE TAPPING SCREWS  $\phi 4 \times 1.6$  FOR FIXING THE UNIT.

DRAWN	27/Feb/2018	I. YAMASAKI	TITLE	HUB-100
CHECKED	27/Feb/2018	H. MAKI	名称	イーサネットスイッチングハブ
APPROVED	28/Feb/2018	H. MAKI	外寸図	
SCALE	1/3	MASS $\pm 10\%$ 1.5 kg	NAME	SWITCHING HUB
DWG. No.	C3519-G18-C	REF. No.	03-163-960G-4	OUTLINE DRAWING

表1 TABLE 1

寸法区分 (mm) DIMENSION	公差 (mm) TOLERANCE
L ≤ 50	±1.5
50 < L ≤ 100	±2.5
100 < L ≤ 500	±3

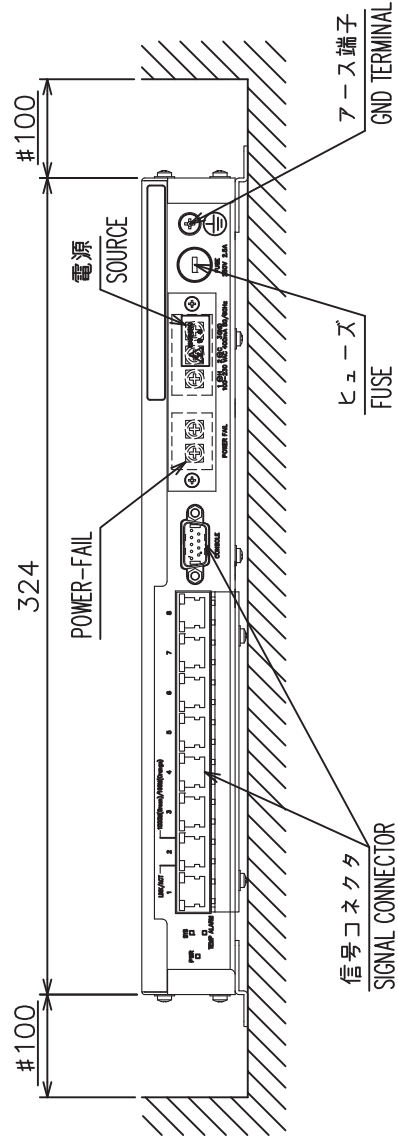
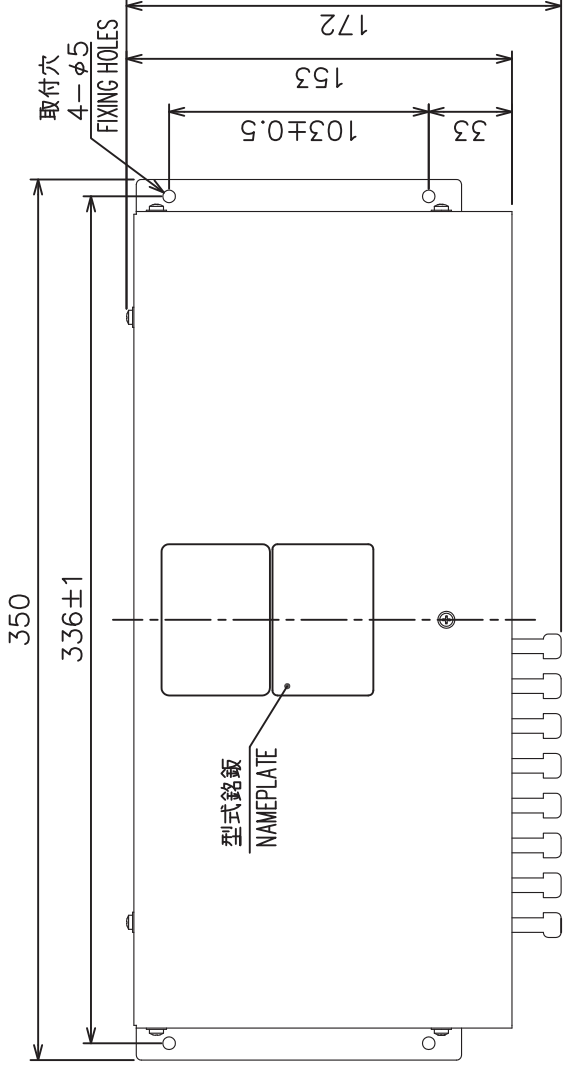
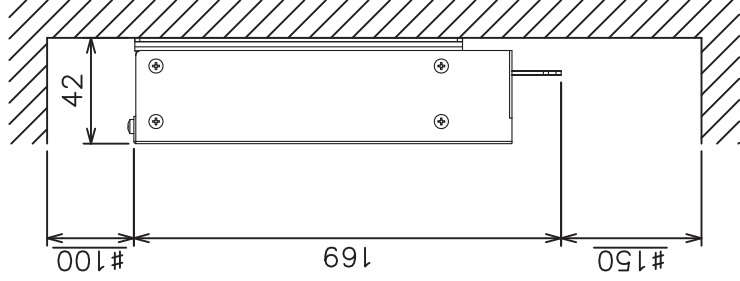

- 注記
- 1) 指定外の寸法公差は表1による。
  - 2) #印寸法は最小サービス空間寸法とする。
  - 3) 取付用ネジはトラスタックピンネジ呼び径4×20を使用のこと。
- NOTE
1. TABLE 1 INDICATES TOLERANCE OF DIMENSIONS WHICH IS NOT SPECIFIED.
  2. # MINIMUM SERVICE CLEARANCE.
  3. USE TAPPING SCREWS φ4x20 FOR FIXING THE UNIT.

DRAWN	5/Nov/2012	T. YAMASAKI	TITLE	HUB-3000
CHECKED	5/Nov/2012	H. MAKI	名称	インテリジェントハブ
APPROVED	7/Nov/2012	Y. NISHIYAMA	外寸図	
SCALE	1/3	質量 1.5 kg	NAME	INTELLIGENT HUB
DWG.No.	C4473-G12-B	REF.No.	24-014-350G-2	OUTLINE DRAWING



表1 TABLE 1

寸法区分 (mm) DIMENSION	公差 (mm) TOLERANCE
L ≤ 50	±1.5
50 < L ≤ 100	±2.5
100 < L ≤ 500	±3

- 注記 1) 指定外の寸法公差は表1による。  
 2) #印寸法は最小サービス空間寸法とする。  
 3) 取付用ネジはトラスタップネジ呼び径4×20を使用のこと。

- NOTE 1. TABLE 1 INDICATES TOLERANCE OF DIMENSIONS WHICH IS NOT SPECIFIED.  
 2. #: MINIMUM SERVICE CLEARANCE.  
 3. USE TAPPING SCREWS φ4x20 FOR FIXING THE UNIT.

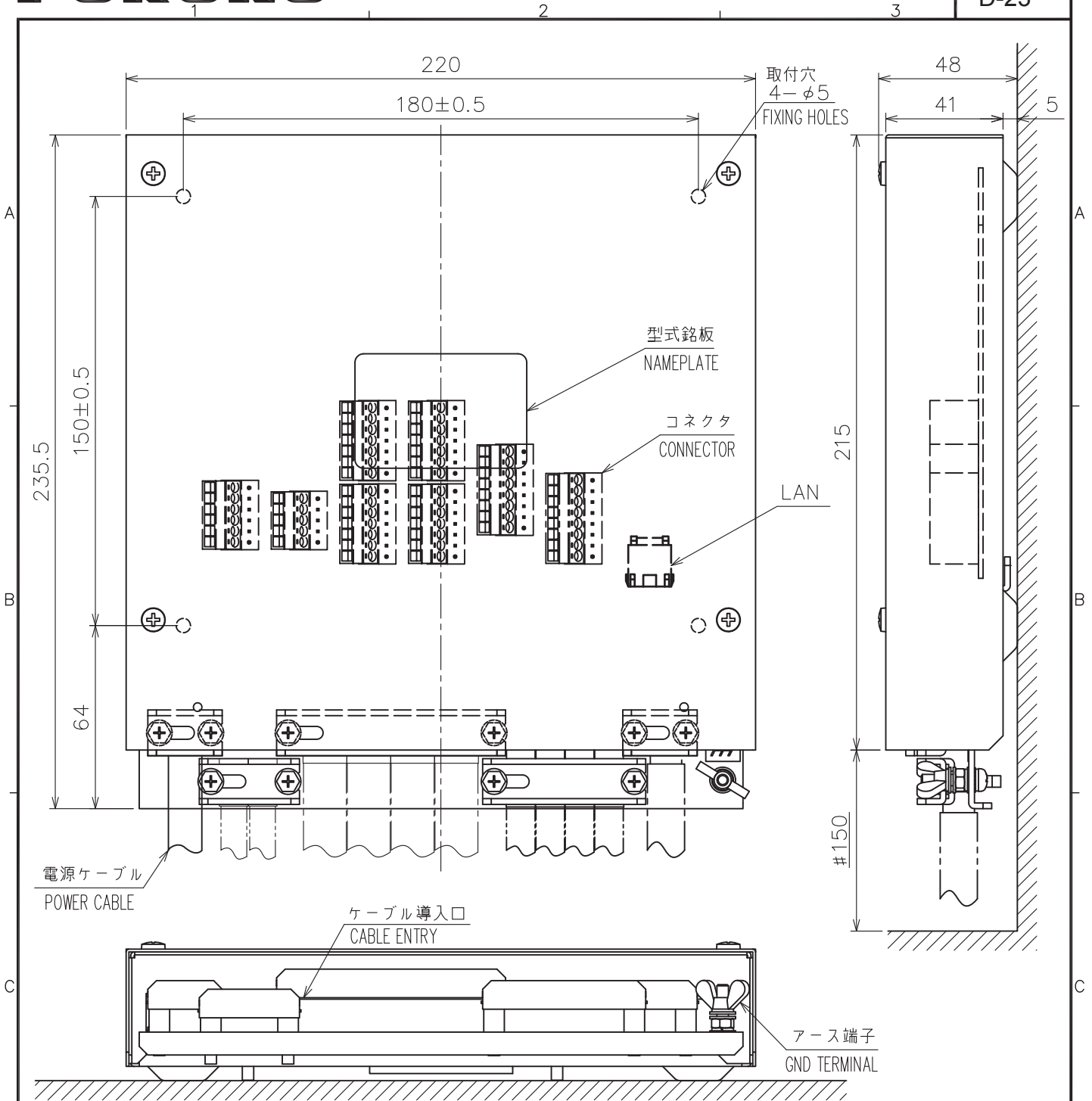
DRAWN 11/Jan/2012 T.YAMASAKI	TITLE MC-3000S
CHECKED 11/Jan/2012 H.MAKI	名称 センサーアダプター (シリアル)
APPROVED 13/Jan/2012 Y.NISHIYAMA	外寸図
SCALE 1/2 MASS 1.5 ±10% kg	質量はケーブルを含まず。 MASS DOES NOT INCLUDE CABLE.
DWG. No. C4473-G08-A	REF. No. 24-014-200G-1
	NAME SENSOR ADAPTER (SERIAL) OUTLINE DRAWING



表1 TABLE 1

寸法区分 (mm) DIMENSION	公差 (mm) TOLERANCE
L ≤ 50	±1.5
50 < L ≤ 100	±2.5
100 < L ≤ 500	±3

- 注記 1) 指定外の寸法公差は表1による。  
 2) #印寸法は最小サービス空間寸法とする。  
 3) 取付用ネジはトラスタップピンネジ呼び径4×20を使用のこと。

- NOTE 1. TABLE 1 INDICATES TOLERANCE OF DIMENSIONS WHICH IS NOT SPECIFIED.  
 2. #: MINIMUM SERVICE CLEARANCE.  
 3. USE TAPPING SCREWS Ø4x20 FOR FIXING THE UNIT.

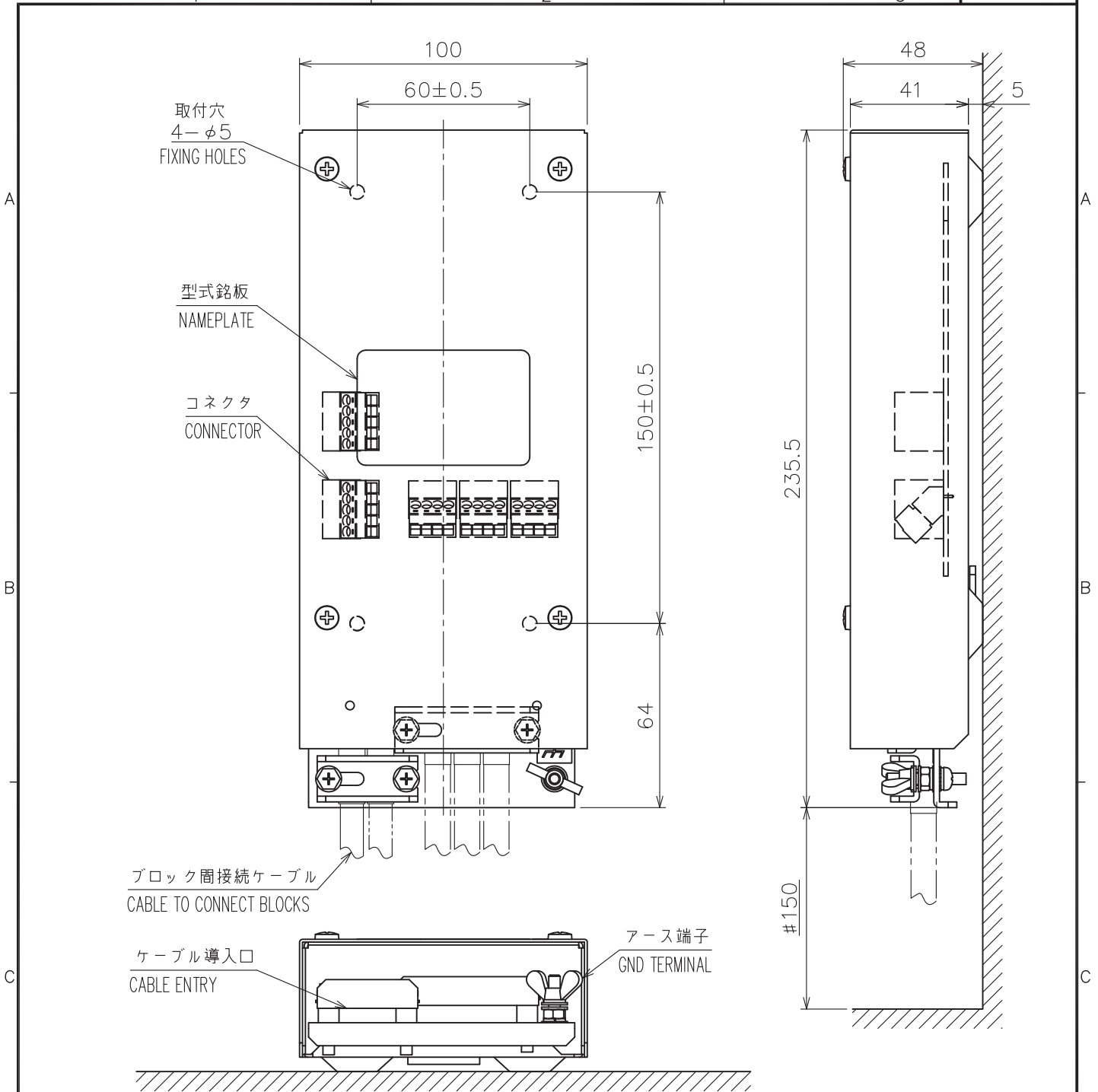
DRAWN 11/Jan/2012 T.YAMASAKI	TITLE MC-3010A
CHECKED 11/Jan/2012 H.MAKI	名称 センサーアダプター (アナログ)
APPROVED 13/Jan/2012 Y.NISHIYAMA	FMD-3200 外寸図
SCALE 1/2	MASS 0.8 ±10% kg
DWG. No. C4473-G09-A	REF. No. 24-014-210G-1
質量はケーブルを含まず。 MASS DOES NOT INCLUDE CABLE.	
NAME SENSOR ADAPTER (ANALOG)	
OUTLINE DRAWING	



表1 TABLE 1

寸法区分 (mm) DIMENSION	公差 (mm) TOLERANCE
L ≤ 50	±1.5
50 < L ≤ 100	±2.5
100 < L ≤ 500	±3

- 注記 1) 指定外の寸法公差は表1による。  
 2) #印寸法は最小サービス空間寸法とする。  
 3) 取付用ネジはトラスタップピンネジ呼び径4×20を使用のこと。

- NOTE 1. TABLE 1 INDICATES TOLERANCE OF DIMENSIONS WHICH IS NOT SPECIFIED.  
 2. #: MINIMUM SERVICE CLEARANCE.  
 3. USE TAPPING SCREWS  $\phi 4 \times 20$  FOR FIXING THE UNIT.

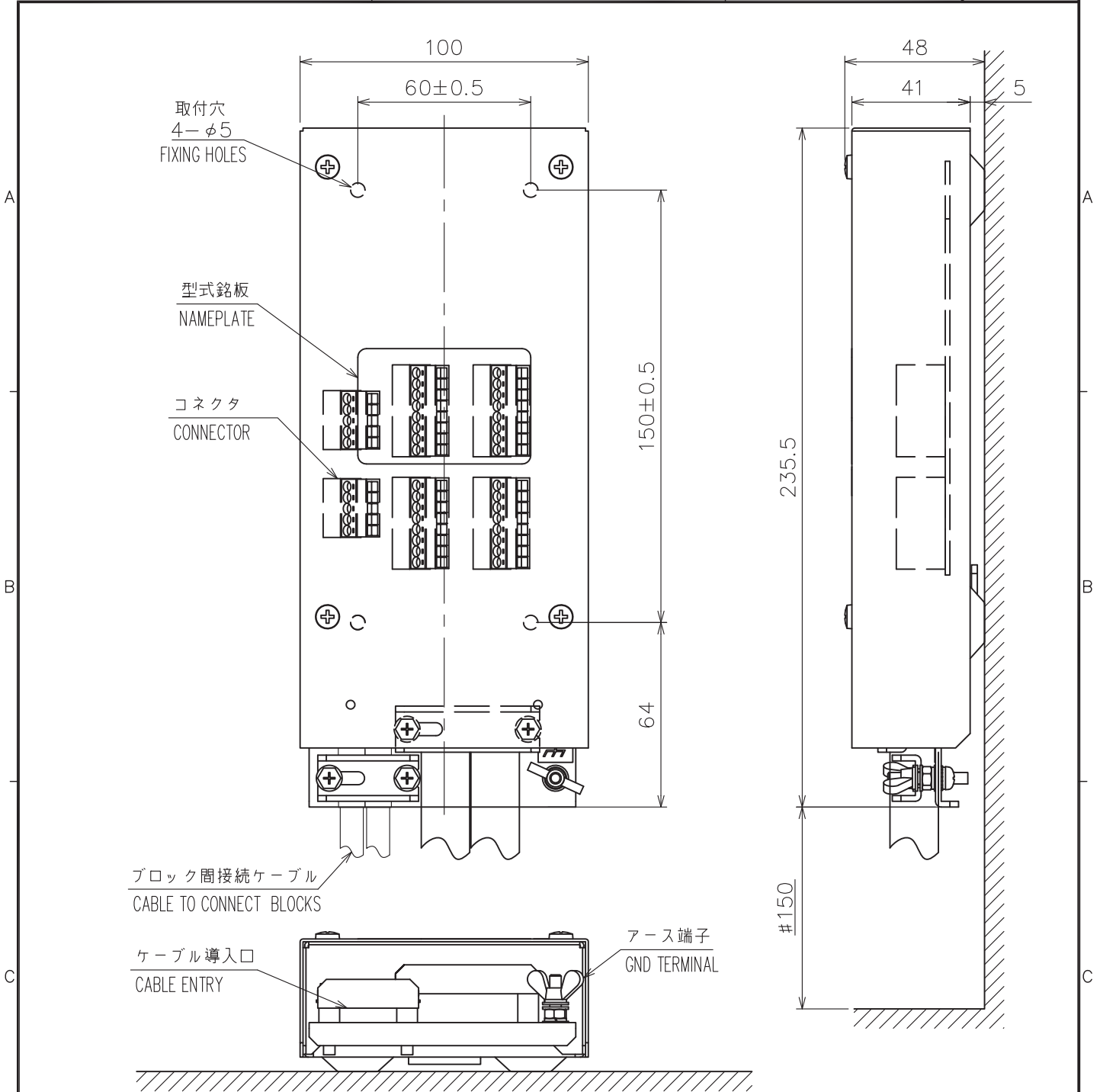
DRAWN 11/Jan/2012 T.YAMASAKI	TITLE MC-3020D
CHECKED 11/Jan/2012 H.MAKI	名称 センサーアダプター (デジタルイン)
APPROVED 13/Jan/2012 Y.NISHIYAMA	外寸図
SCALE 1/2 MASS 0.8 ±10% kg 質量はケーブルを含まず。 MASS DOES NOT INCLUDE CABLE.	NAME SENSOR ADAPTER (DIGITAL IN)
DWG. No. C4473-G10-A	REF. No. 24-014-220G-1 OUTLINE DRAWING



表1 TABLE 1

寸法区分 (mm) DIMENSION	公差 (mm) TOLERANCE
L ≤ 50	±1.5
50 < L ≤ 100	±2.5
100 < L ≤ 500	±3

- 注記 1) 指定外の寸法公差は表1による。  
 2) #印寸法は最小サービス空間寸法とする。  
 3) 取付用ネジはトラスタップピンネジ呼び径4×20を使用のこと。

- NOTE 1. TABLE 1 INDICATES TOLERANCE OF DIMENSIONS WHICH IS NOT SPECIFIED.  
 2. #: MINIMUM SERVICE CLEARANCE.  
 3. USE TAPPING SCREWS Ø4x20 FOR FIXING THE UNIT.

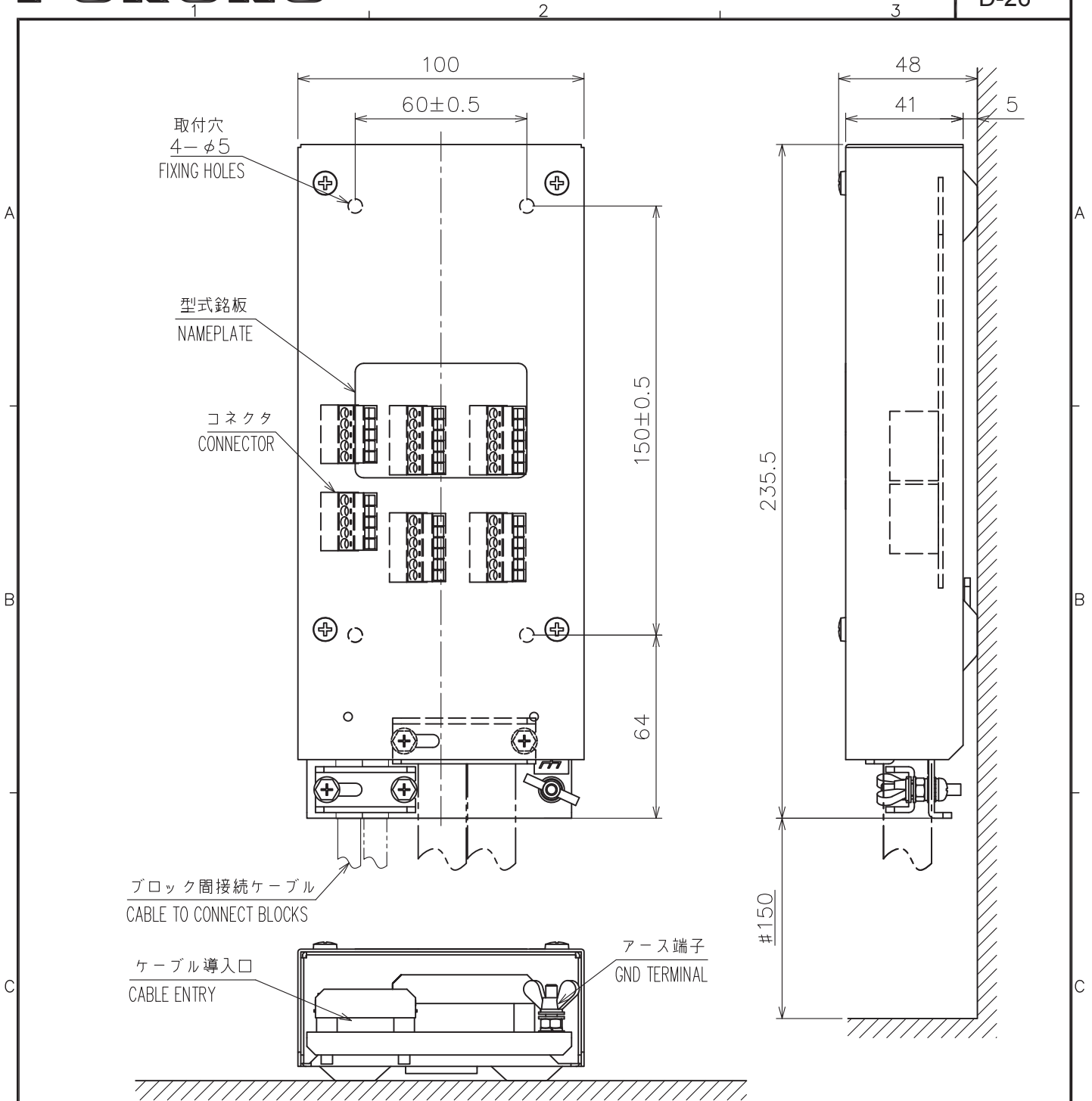
DRAWN 11/Jan/2012 T.YAMASAKI	TITLE MC-3030D
CHECKED 11/Jan/2012 H.MAKI	名称 センサーアダプター (デジタルアウト)
APPROVED 13/Jan/2012 Y.NISHIYAMA	FMD-3200 外寸図
SCALE 1/2	MASS 0.8 ±10% kg
DWG. No. C4473-G11-A	REF. No. 24-014-230G-1
質量はケーブルを含まず。 MASS DOES NOT INCLUDE CABLE.	
NAME SENSOR ADAPTER (DIGITAL OUT)	
OUTLINE DRAWING	

表1 TABLE 1

寸法区分 (mm) DIMENSION	公差 (mm) TOLERANCE
L ≤ 50	±1.5
50 < L ≤ 100	±2.5
100 < L ≤ 500	±3
500 < L ≤ 1000	±4

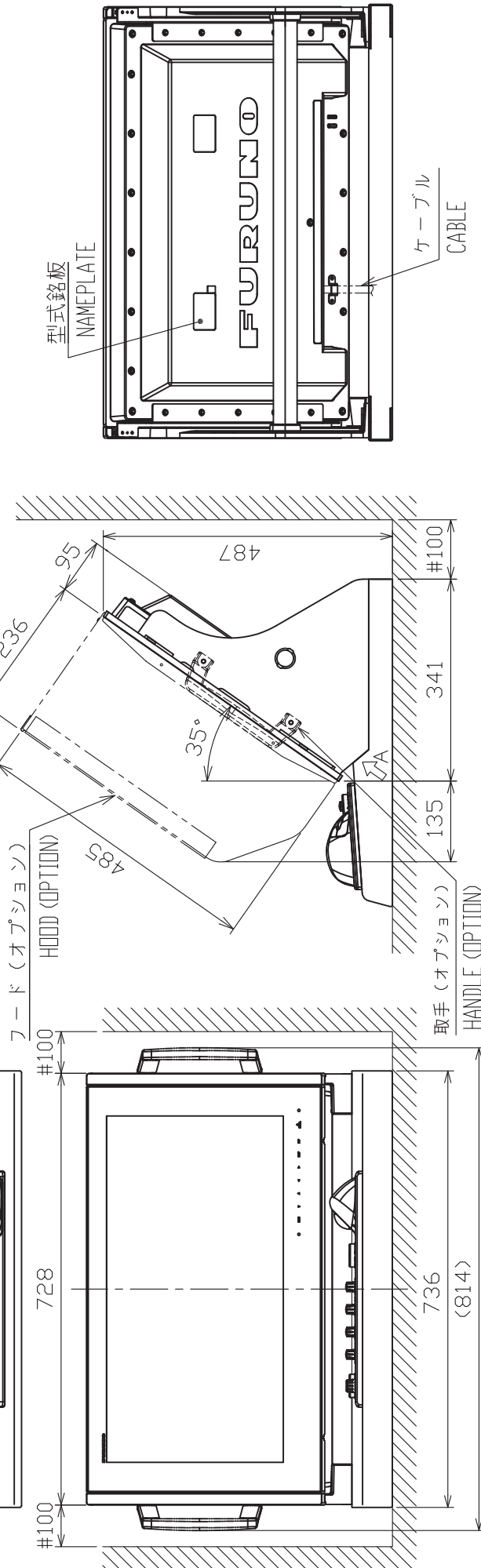
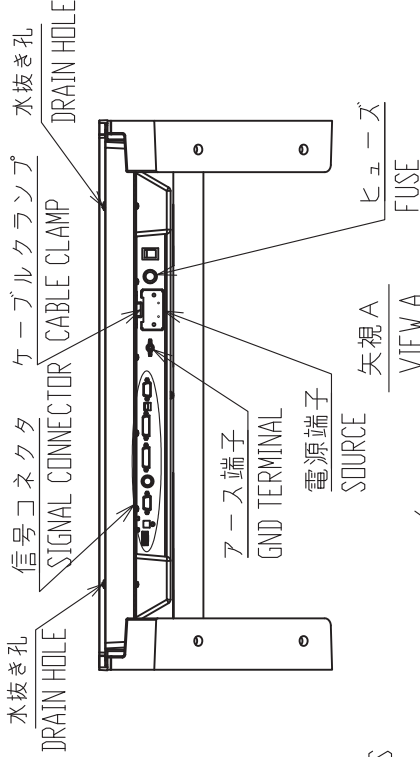

注記 1) 指定外の寸法公差は表1による  
 2) #印寸法は最小サービス空間寸法とする  
 3) 取付用ネジはM10ボルトまたはコーチボルト呼び径9を使用のこと。

NOTE 1. TABLE 1 INDICATES TOLERANCE OF DIMENSIONS WHICH IS NOT SPECIFIED.  
 2. # MINIMUM SERVICE CLEARANCE.  
 3. USE M10 BOLTS OR COARCH SCREWS Ø9 FOR FIXING THE UNIT.

DRAWN	12/Dec/2016	I.YAMASAKI	TITLE	MU-270W
CHECKED	12/Dec/2016	H.MAKI	名称	表示部 (連結台タイプ)
APPROVED	12/Dec/2016	H.MAKI	外寸図	
SCALE	1/10	100% #32 kg	NAME	MONITOR UNIT (CONNECTION STAND TYPE)
JWG.No.	C4493-604-A		REF.No.	26-009-130G-0
				OUTLINE DRAWING

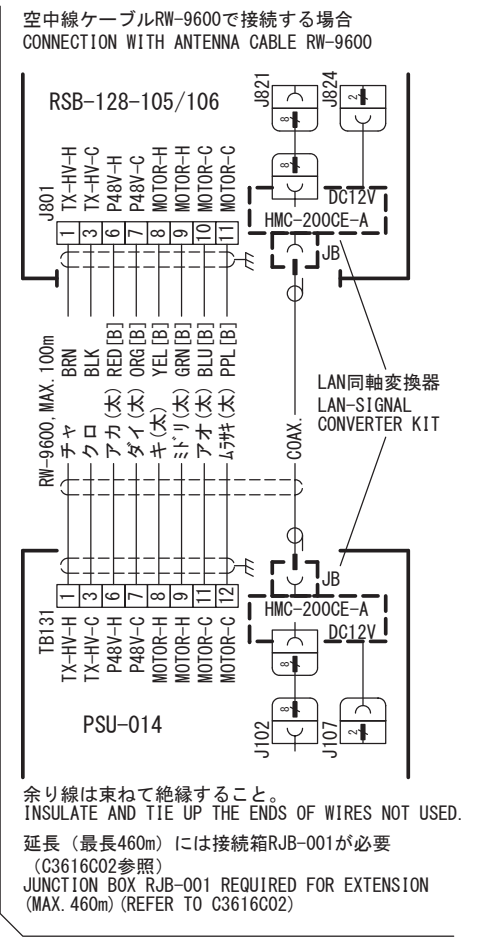
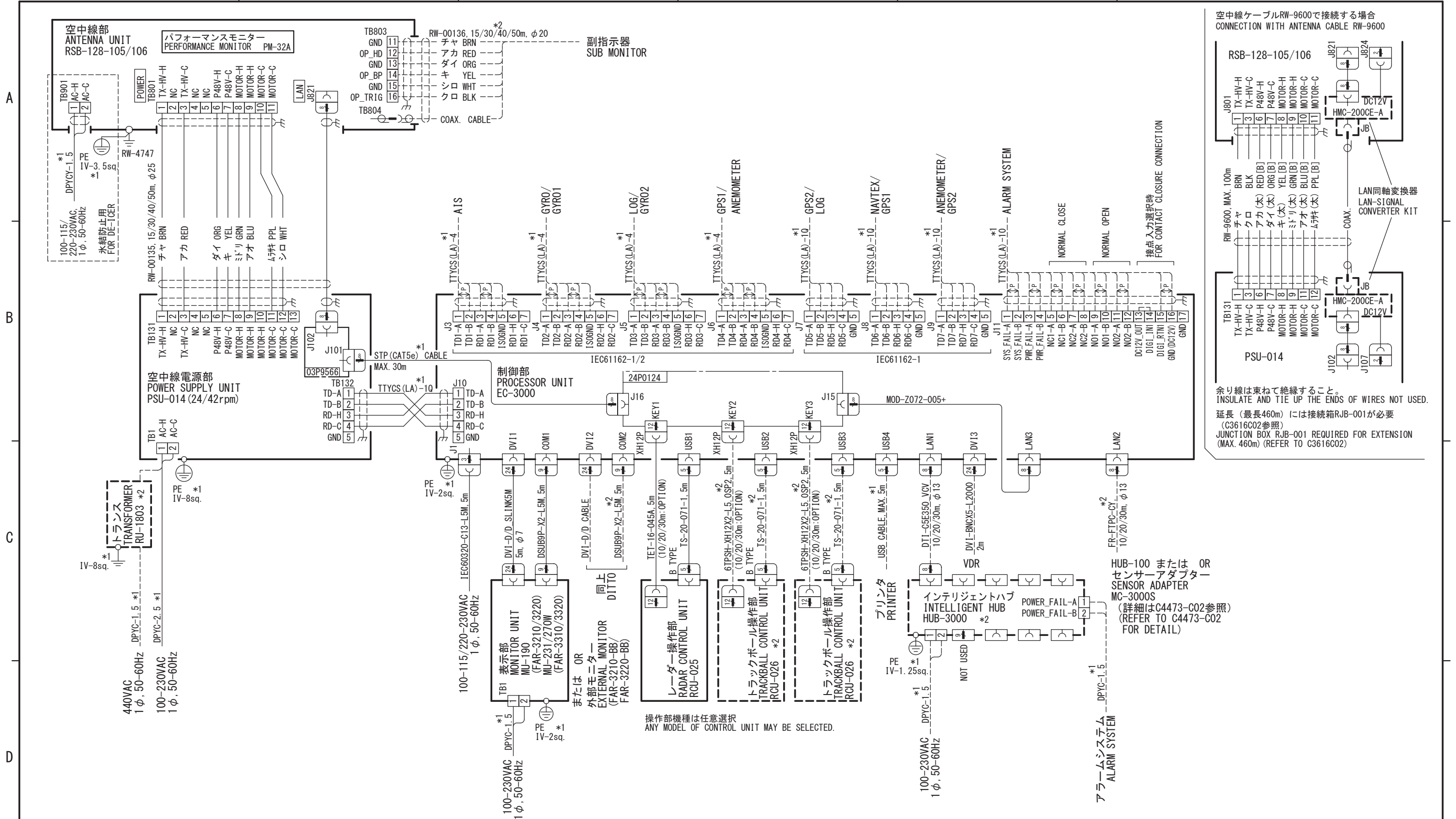

余り線は束ねて絶縁すること。  
INSULATE AND TIE UP THE ENDS OF WIRES NOT USED.  
延長 (最長460m) には接続箱RJB-001が必要  
(C3616C02参照)  
JUNCTION BOX RJB-001 REQUIRED FOR EXTENSION  
(MAX. 460m) (REFER TO C3616C02)

操作部機種は任意選択  
ANY MODEL OF CONTROL UNIT MAY BE SELECTED.

注記  
\* 1) 造船所手配。  
\* 2) オプション。

NOTE  
\*1: SHIPYARD SUPPLY  
\*2: OPTION

DRAWN	12/Dec/2017 R. FUJIIYAMA	TYPE	FAR-3210/3220 (-BB), FAR-3310/3320
CHECKED	12/Dec/2017 T. YAMASAKI	名称	航海用レーダー
APPROVED	9/Nov/2016 H.MAKI		相互結線図
SCALE	MASS kg	NAME	MARINE RADAR
DWG. No.	C3616-C01- G	REF. No.	03-183-6002-1
		INTERCONNECTION DIAGRAM	



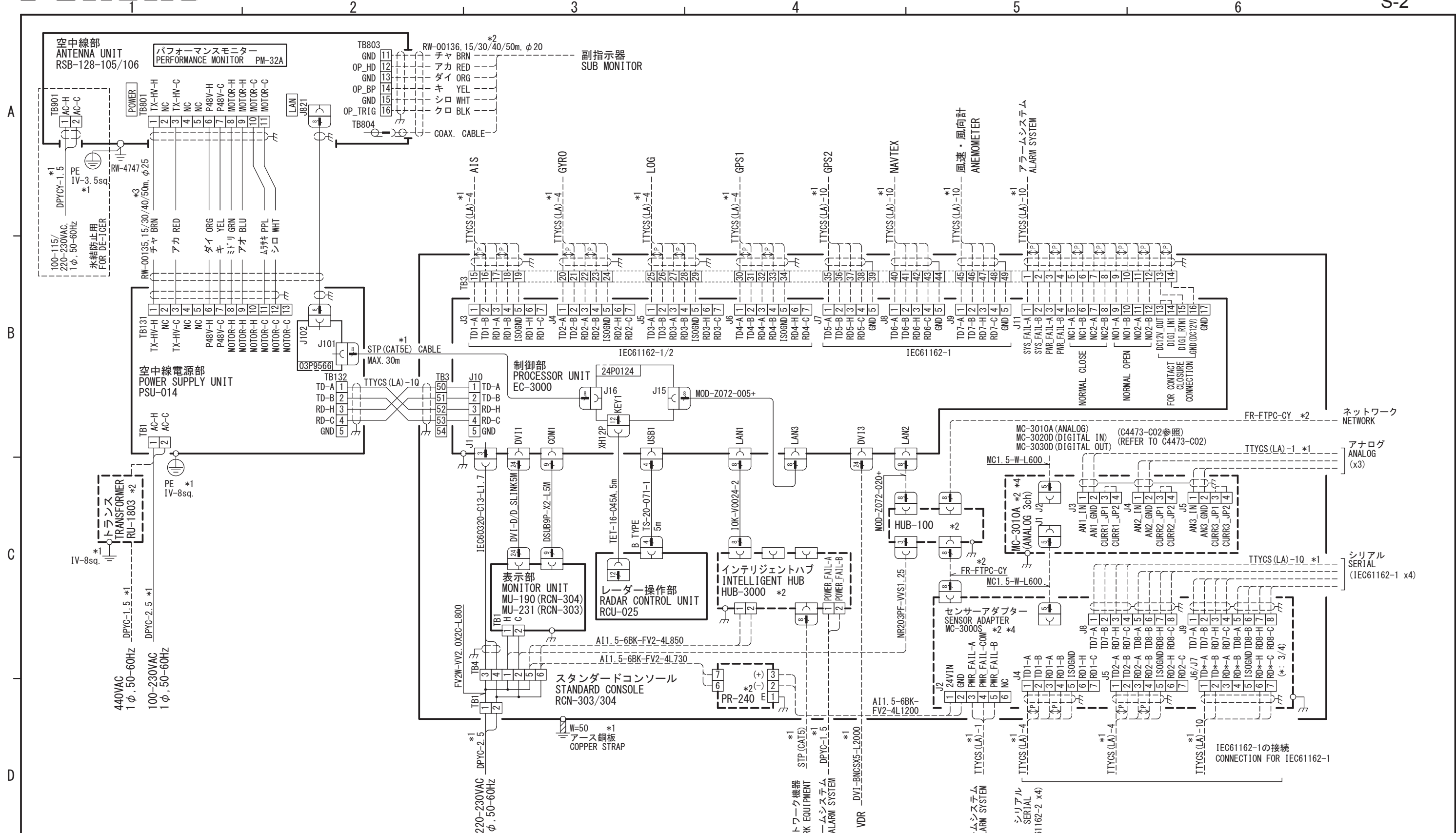

注記  
 \* 1) 造船所手配。  
 \* 2) オプション。  
 \* 3) 既設ケーブル利用、ケーブル延長についてはC3616-C01/C02を参照のこと。  
 \* 4) センサーアダプターは、MC-3000Sを含む3台までコンソール内収納可。

NOTE  
 \*1: SHIPYARD SUPPLY  
 \*2: OPTION  
 \*3: REFER TO C3616-C01/02 FOR USING RETRO-FIT CABLE OR CABLE EXTENSION.  
 \*4: A CONSOLE CAN INCLUDE THREE UNITS (MC-3000S INCLUDED) AMONG SENSOR ADAPTERS.

TYPE	REMARK
A	オプションを含まず。 W/O OPTIONAL UNIT.
B	オプションを含む。 INCLUDES OPTIONAL UNIT.
C	オプションおよびUPS取付板を含む。 INCLUDES OPTIONAL UNIT AND UPS FIXTURE.

DRAWN	13/Dec/2017 R. FUJIIYAMA	TITLE	RCN-303/304-A/B/C
CHECKED	13/Dec/2017 T. YAMASAKI	名称	スタンダードコンソール (航海用レーダー)
APPROVED	29/Sep/2014 H.MAKII	相互結線図	
SCALE	MASS kg	NAME	STANDARD CONSOLE (MARINE RADAR)
DWG. No.	C3616-C03- C	REF. No.	03-183-6031-1
		INTERCONNECTION DIAGRAM	

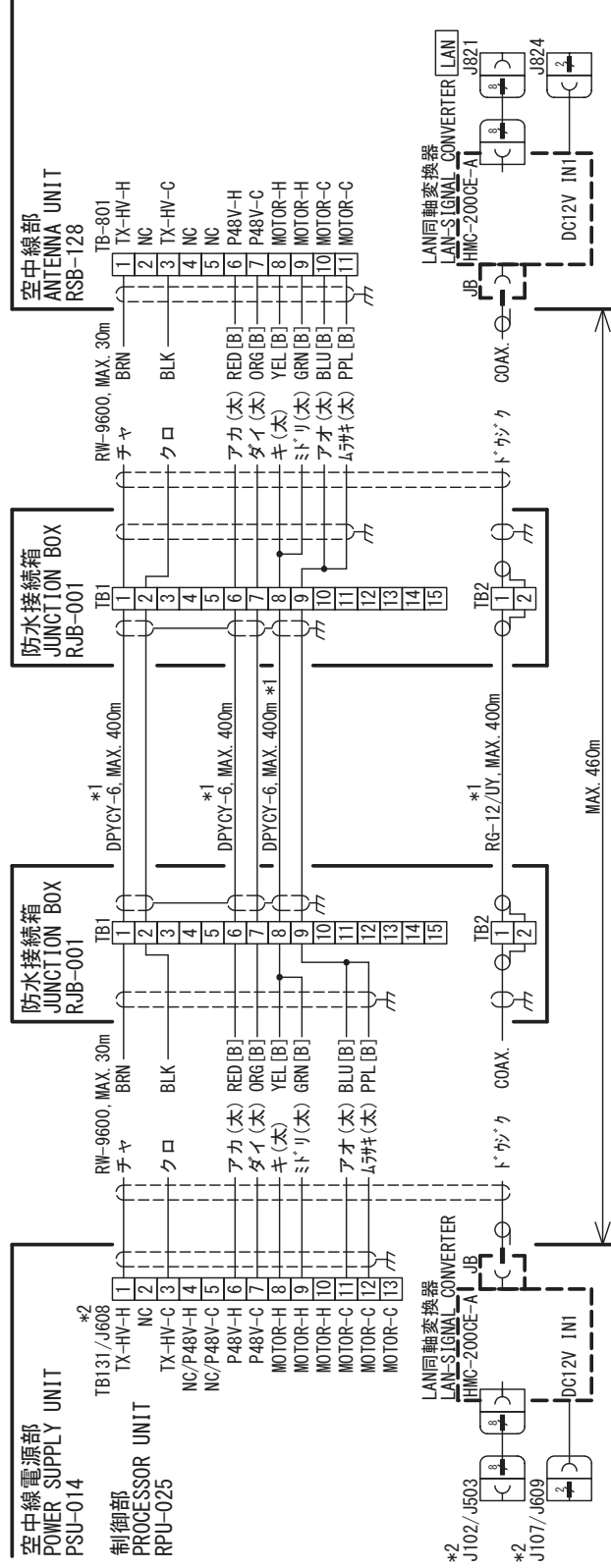

A

B

C

注記

- \* 1) 造船所手配。
- \* 2) 併記された番号は、PSU-014/RPU-025の順。

NOTE

- \*1: SHIPYARD SUPPLY.
- \*2: THE CONNECTOR NUMBERS ARE SHOWN AS PSU-014/RPU-025 ORDER.

DRAWN	15/Sep/2017	I. YAMASAKI	TITLE	RJB-001
CHECKED	15/Sep/2017	H. IMAKI	名称	防水接続箱 (空中線ケーブル延長)
APPROVED	15/Sep/2017	H. IMAKI	相互接続図	
			NAME	JUNCTION BOX (ANTENNA CABLE EXTENSION)
DWG. No.	C3616-C02-G	REF. No.	INTERCONNECTION DIAGRAM	

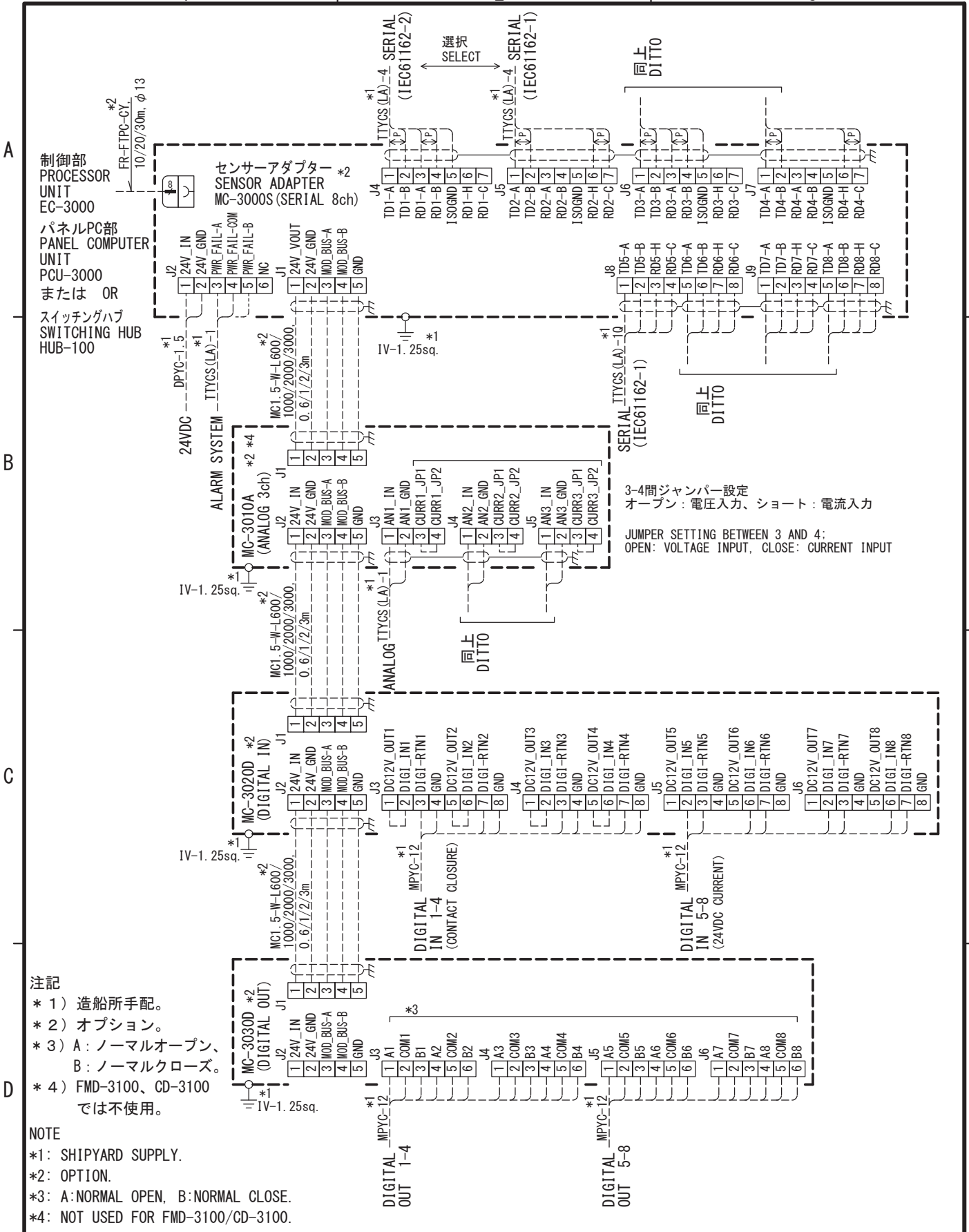

DRAWN 8/Dec/2017 T. YAMASAKI	CHECKED 8/Dec/2017 H. MAKI	APPROVED 8/Dec/2017 H. MAKI	SCALE MASS kg	DWG. No. C4473-C02- E	REF. No. 24-014-6003-2	TITLE MC-3000S/3010A/3020D/3030D	名称 センサーアダプター	相互結線図	NAME SENSOR ADAPTER
						INTERCONNECTION DIAGRAM			